



Document-34912
Updated 2/2021

Summit Information Booklet

For the first ten years of operation, Vera C. Rubin Observatory will perform the Rubin Observatory Legacy Survey of Space and Time, using the Rubin Observatory LSST Camera and the Simonyi Survey Telescope.



U.S. DEPARTMENT OF
ENERGY

SLAC

CHARLES AND LISA SIMONYI FUND
••• FOR ARTS AND SCIENCES •••



Our Mission

Rubin Observatory's mission is to build a well-understood system that will produce an unprecedented astronomical data set for studies of the deep and dynamic universe, make the data widely accessible to a diverse community of scientists, and engage the public to explore the Universe with us.



Title: Eclipse over Rubin Observatory Facility

Description: A total solar eclipse occurred on July 2, 2019 over the facility building

Location: Cerro Pachón, Chile

Credit: K. Reil Rubin Observatory/AURA/SLAC/NSF/DOE

AURA Site

La Serena to Cerro Pachón:

Distance: 94 km (58 miles)

Driving time: ~1.5 - 2 hrs

Difference in altitude: 2600 m

The Association of Universities for Research in Astronomy (AURA) Observatory site in Chile consists of two sections of land, owned by AURA since 1961. The actual observatory sites are located on AURA's "Estancia El Totoral," a site of more than 90,000 acres, which includes two operational mountaintops: Cerro Tololo, (elevation 2,200 meters), and Cerro Pachón (elevation 2,750 meters). In La Serena, AURA-O operates the "AURA Recinto," a 33-acre compound housing offices, laboratories, and facilities support staff.

Cerro Pachón was selected as the site for Rubin Observatory in 2006, following a two-year campaign of in-depth testing and analysis of the atmospheric conditions and quality of astronomical seeing at four candidate sites.

Important factors when considering a site for Rubin Observatory included the number of clear nights per year, seasonal weather patterns, and the quality of images as seen through the local atmosphere. The chosen site also needed to have an existing observatory infrastructure and access to fiber optic links, to accommodate the anticipated 20 terabytes of data the Observatory will produce each night.

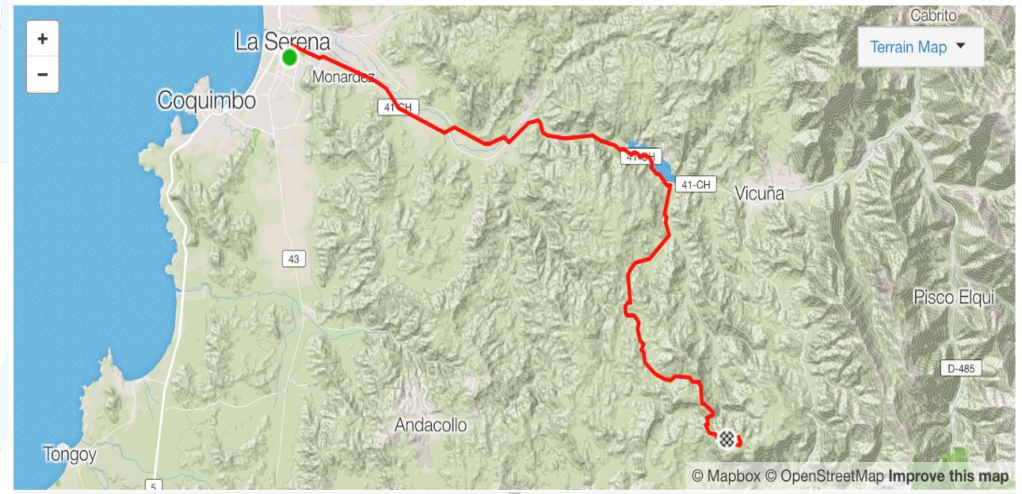

Drone View

June 2021



Rubin Observatory Site

The Rubin Observatory Project received private funding in 2008 that allowed the fabrication of the Primary/Tertiary Mirror (M1M3), the construction of the Secondary mirror (M2) glass, and the initial site preparation work. Federal funding from the National Science Foundation (NSF) was received in 2014, and the official start of Federal Construction was marked by this First Stone event on April 14, 2015. Laying of the first stone is a Chilean tradition marking the construction start for a new astronomical observatory. Chilean President Michelle Bachelet, U.S. Ambassador to Chile Michael A. Hammer, NSF Director France Córdova, and Charles Simonyi are among the dignitaries who were present to mark the start of summit construction.

The Rubin Observatory site on Cerro Pachón includes a service and operations building, an auxiliary telescope building, a cafeteria (referred to as the Rubin Observatory Casino), and a service area.

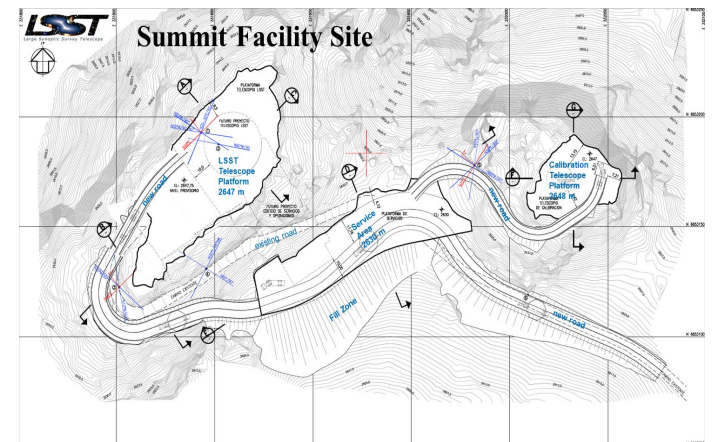

Rubin Observatory Summit Facility

Service & Operations Building gross area: ~2,500 m² (26,900 sq ft)

Elevation: 2667m

The Rubin Observatory summit facility is a 10-story structure that includes the telescope pier, a lower enclosure (30 meters in diameter) that supports a rotating dome, and an attached 32,000-square-foot (3000-square-meter) service and operations building. A separate enclosure nearby houses the Rubin Observatory Auxiliary Telescope.

The design for the Rubin Observatory summit facility takes advantage of the natural topography of the El Peñón summit on Cerro Pachón. The Simonyi Survey Telescope enclosure occupies the highest and largest peak, and the attached service and operations building steps down into a saddle area to the southeast. The Auxiliary Telescope is located on a smaller peak farther to the east. The specific orientation of the summit facility was selected after extensive weather testing and a computational fluid dynamics (CFD) analysis of the site verified that it provided the best seeing environment, or the least air disturbance, for the telescope. Geotechnical studies of the natural rock at the site have shown that it is strong and erosion-resistant.

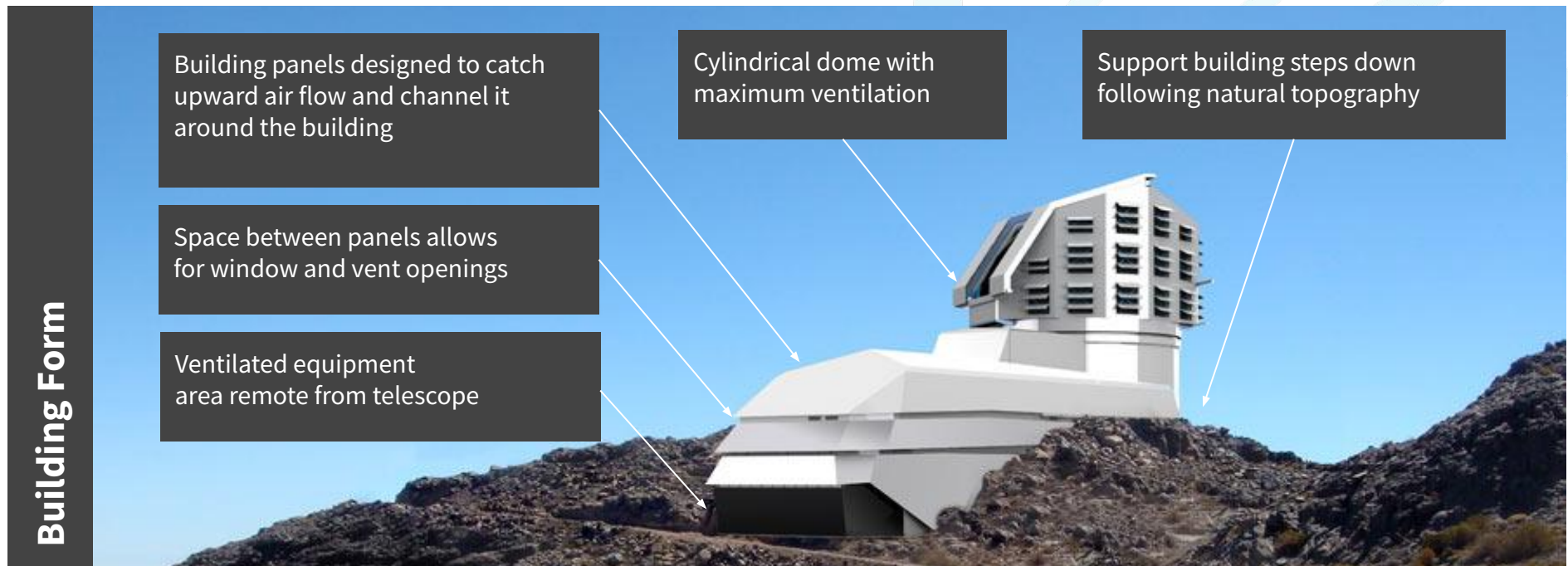

Summit Facility

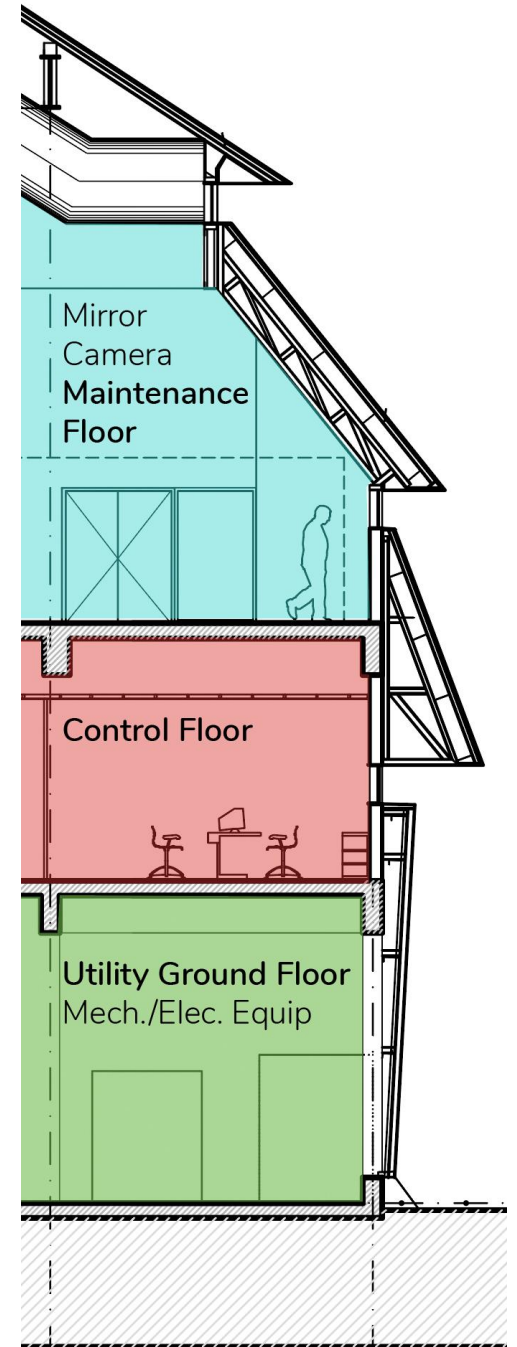
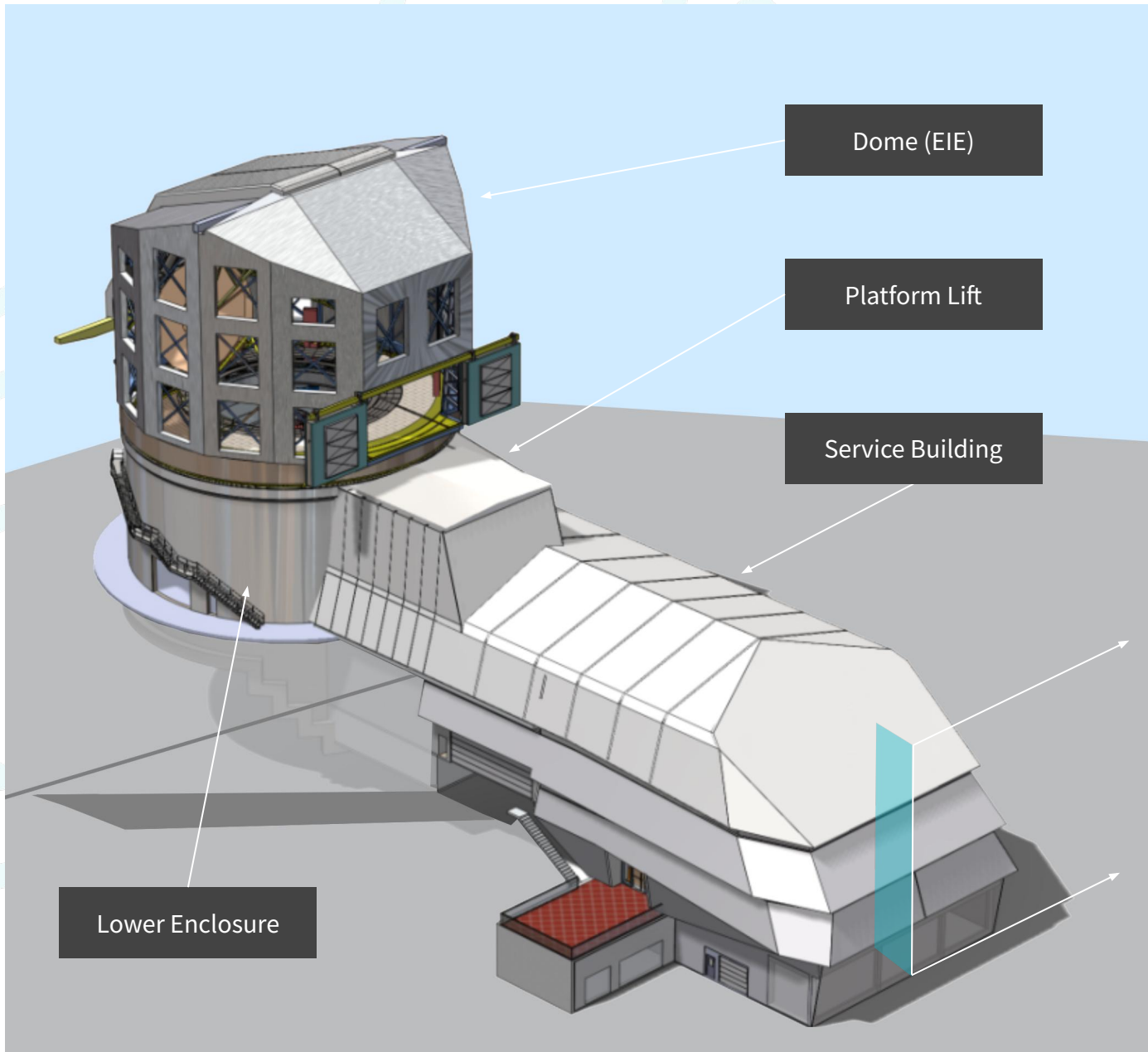

Telescope Enclosure/Service Building

Service Building – 2,630 m² (28,300 ft²) gross area

1. Utility Ground Floor: main entry, shop, mech./elect. equip., camera refrigeration
2. Control Floor: control room, computing, general office/support areas
3. Maintenance Floor: mirror coating & camera maintenance
4. Mezzanine Floor: elevated catwalk to the Simonyi Survey Telescope, staging platforms, camera HVAC
5. Enclosure Ground Floor/Upper Service Floor: connecting level between buildings
 - Platform Lift for conveyance of mirrors & camera

Telescope Pier & Enclosure –

16m D & 30m D – 707 m² (7,600 ft²)

1. Lower Enclosure Floor: utility access, shop, storage
2. Pier Intermediate and Upper Floors: electrical, utility access
3. Dome Floor: access to telescope and dome
4. Telescope Maintenance Platform: service access to telescope

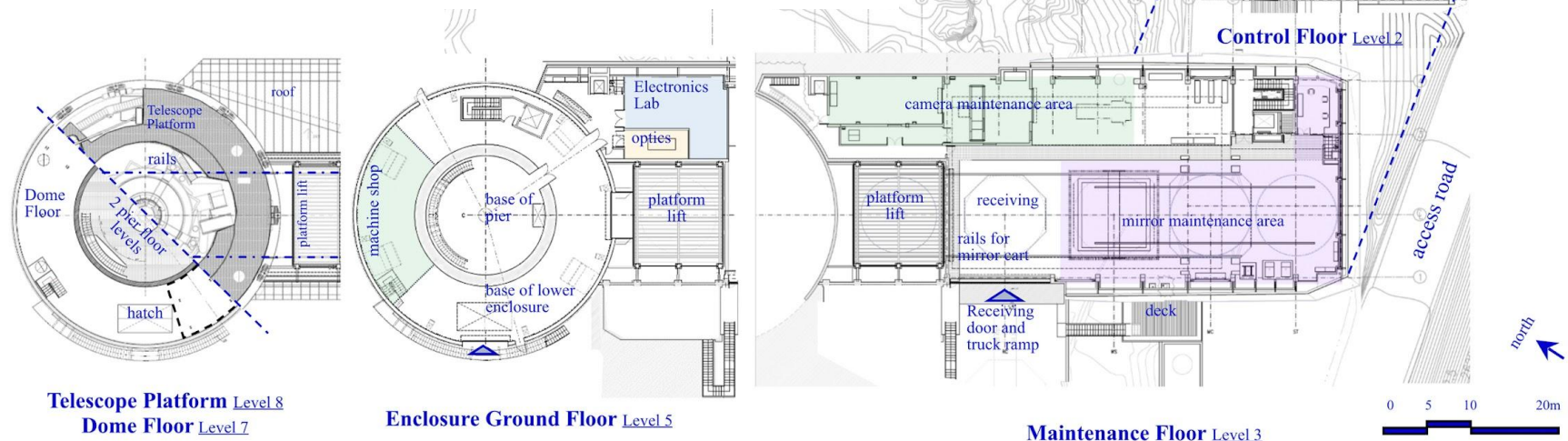

Computer Room

Status: Complete and operational

Size: 50 square meters (164 square feet)

Temperature: 18-22 degrees Celsius (64-72 degrees Fahrenheit)

The computer room can be thought of as the heart and brain of the summit. This is a 50 M² room with sufficient power and cooling for 14 racks (like those shown in the photo). The Uninterruptible Power Supply (UPS) should last 8 hours. The raised floor must support an 1800 lb (816 kg) fully loaded 48U rack. The room is designed for up to 65kW power draw. The modern computers mean this room temperature is maintained between 18 and 22 degrees Celsius. The room was designed with earthquakes in mind as well.

13 x 24-strand fiber cables from the camera run into the data acquisition systems housed here, and 100 Gbps network fibres travel from here to the base using Dense Wave Division Multiplex (DWDM). The computer room pumps the data out of the facility.

These racks are also populated with control computers for the myriad devices around the observatory. The mount, mirror, and lenses all have control processes running in the computer room. The engineering facility database, which records all events and messages on the mountain, lives here.

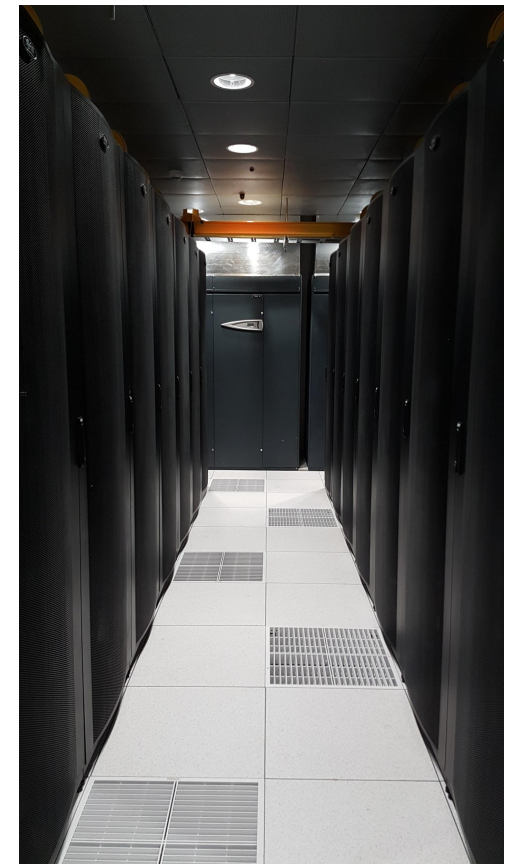
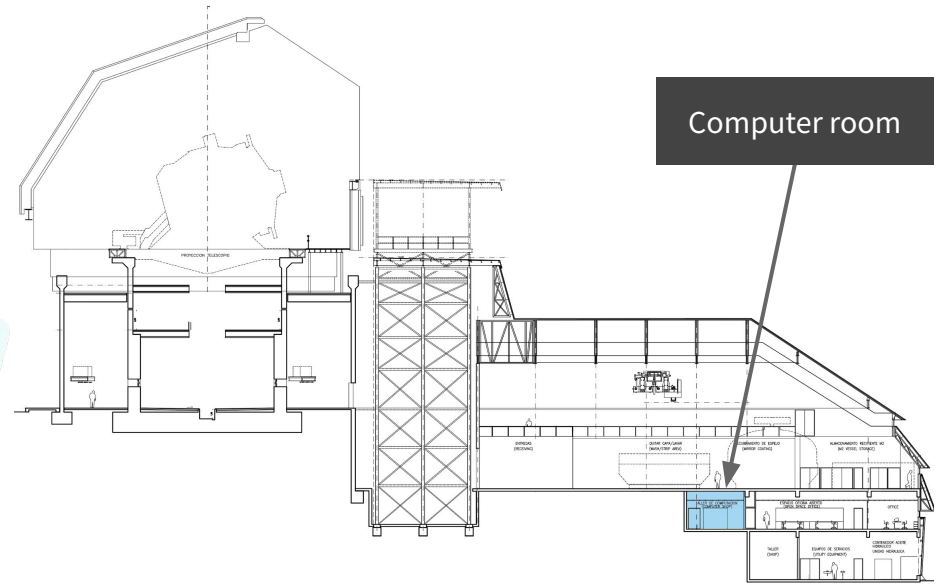

Coating Plant

Manufactured by: Von Ardenne, Germany

Status: Complete and operational

Size: ~9 meters in diameter

Weight: 128 tons



In July, 2019, Rubin Observatory's coating chamber was used to coat the glass Secondary Mirror (M2) with protected silver. It will coat the Primary/Tertiary Mirror (M1M3) with aluminum.

During the Rubin Observatory's 10-year Legacy Survey of Space and Time, its mirrors will be exposed to the elements each night as the Simonyi Survey Telescope surveys the sky through the open side of the observatory dome. Over time the mirrors will get dusty, and the mirror coatings may develop small blemishes that eventually affect performance. To ensure that Rubin Observatory continues to collect the sharpest possible images of the night sky, its mirrors will undergo periodic washing and recoating. It's anticipated that the Primary/Tertiary Mirror (M1M3) will need to be recoated every two years, and the Secondary Mirror (M2) every five years, during the 10-year survey.



Both the washing and recoating will be done inside the observatory's coating plant; special equipment will be used to remove and transport the mirrors from the telescope to the washing station and coating chamber.

The Rubin Observatory coating chamber uses magnetron sputtering technology, a method that has proven successful with mirrors for other large telescopes including the twin Gemini Telescopes and the European Southern Observatory Very Large Telescope. There are two rings of magnetrons inside the coating chamber: an inner ring that will be used to apply coatings to the M2 mirror and the M3 mirror, and an outer ring that will apply coatings to the 8.4-meter M1 mirror.

Rubin Observatory LSST Camera Field of View

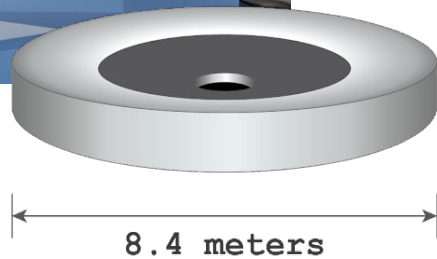
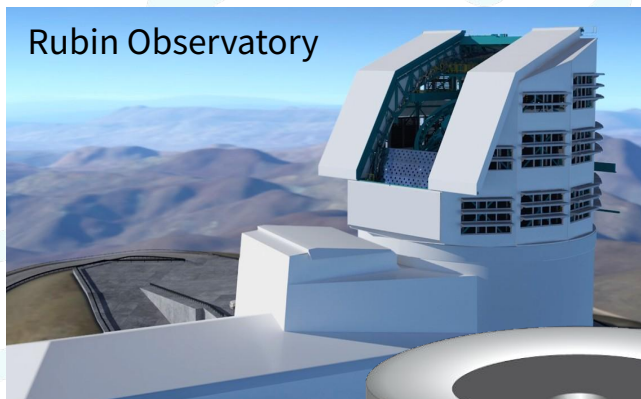
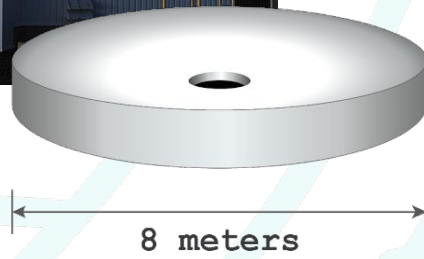
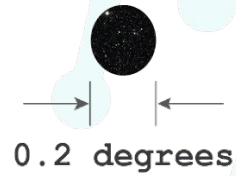

Primary/Tertiary Mirror

Manufactured by: Richard F. Caris Mirror Lab,
University of Arizona, USA

Status: Complete and in storage on
Cerro Pachón since May, 2019

Size: 8.4 meters (27.6 feet)

Weight: ~37,000 lbs (16,780 kg)

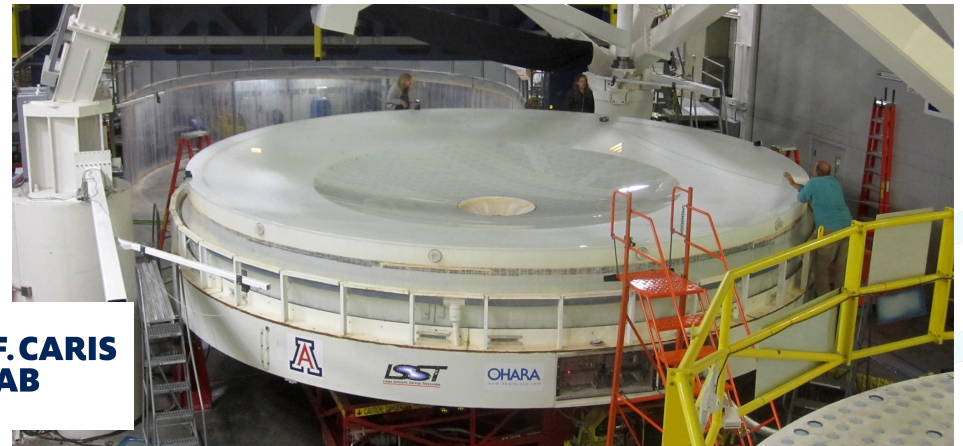

The Rubin Observatory Primary/Tertiary Mirror (M1M3) consists of two mirror surfaces combined on one large substrate. Light from the sky will hit the 8.4-meter outer ring (M1) first, reflect upwards to a separate second mirror (M2), and then bounce back down to the 4.8-meter inner ring (M3) of the monolith before reaching the LSST Camera.

Combining two astronomical mirrors with different curvatures into one surface had not been done before, but it is this unique design that will enable Rubin Observatory to achieve speed with a crisp, wide field of view.

The M1M3 was fabricated over a period of approximately seven years at the Richard F. Caris Mirror Lab at the University of Arizona. The "High Fire" event, in which the glass was cast, took place in March 2008. The mirror was completed in April 2015 after years of grinding and polishing brought the surfaces to the required specifications.

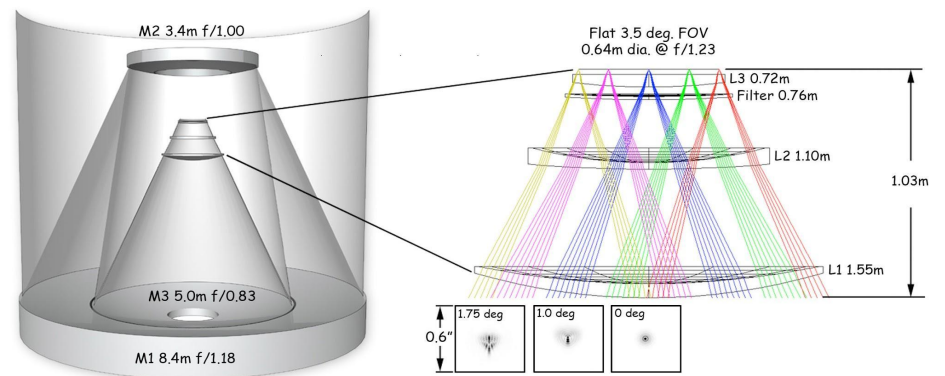
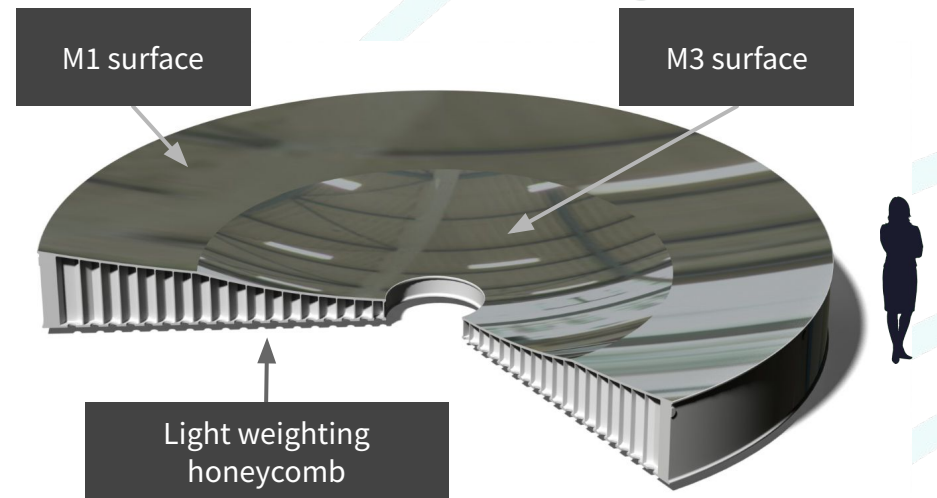

M1M3 Cell

Designed by: Rubin Observatory Engineering Department

Manufactured by: CAID Industries and NSF's National Optical-Infrared Astronomy Research Laboratory, Tucson, AZ

Status: Complete. Arrived at summit in July, 2019

Size: M1 = 8.4m/M3 =4.8 m

Weight: ~38 Tons (55 Tons with mirror on top)

The M1M3 Cell is considered to be the most sensitive subsystem of the Simonyi Survey Telescope and hence its design was carried out completely in-house by Rubin Observatory's engineering department. The cell provides gravity support, figure correction and thermal compensation to the mirror along with inertia compensation during the rapid telescope slews. It also functions as the lower vacuum chamber vessel to enable coating of the M1M3 mirror surface.

The main 9m x 9m x 2m (30ft x 30ft x 7ft) steel structure was fabricated at CAID Industries in Tucson, AZ, while the mechanical, electrical, and electronics components were fabricated by NSF's National Optical-Infrared Astronomy Research Laboratory in Tucson, AZ. After the cell's completion in 2018, it was integrated with the M1M3 mirror for optical testing at the Richard F. Caris Mirror Lab at The University of Arizona.

The M1M3 Cell arrived on Cerro Pachón in July, 2019. It has been integrated with the M1M3 transport cart and the M1M3 surrogate mirror, a steel structure that approximates the mass and center of gravity of the glass mirror during testing.

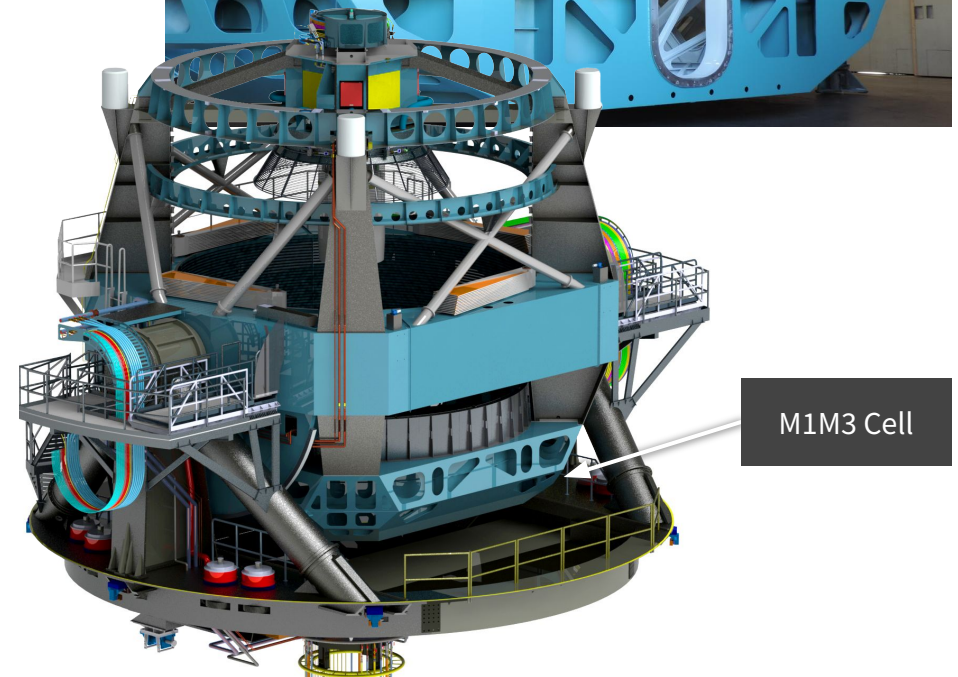
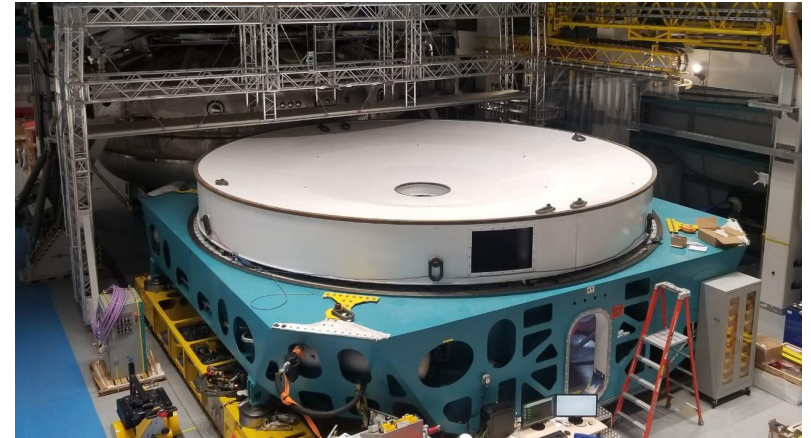

Secondary (M2) Mirror

Manufactured by:

- Optical polish and system by L3 Harris Technologies, Inc., Rochester NY, USA
- Glass substrate by Corning Glass, Canton NY, USA

Status: Complete. Arrived at Cerro Pachón in early 2019, and coated with protected silver on July 16, 2019.

Size: 3.4 meters

Weight: ~1614 kg (3558lb)

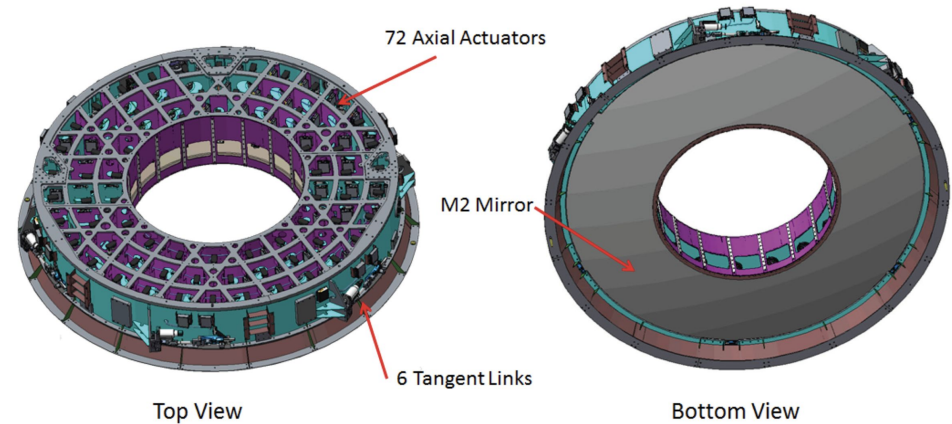

At 3.42 meters in diameter, the Rubin Observatory secondary mirror (M2) is the largest convex mirror ever made. The mirror blank is composed of an ultra-low expansion glass (ULE) from Corning USA to form a 100mm-thick meniscus mirror.

L3 Harris Technologies, Inc. manufactured the M2, as well as the mirror's cell assembly. The full assembly consists of the polished secondary mirror, mirror support system, mirror cell electronics and sensors, thermal control system, and the mirror control system. It is supported by 72 axial actuators and 6 tangential actuators. The M2 assembly has a large 1.6m diameter hole in its center to allow for the installation of the Rubin Observatory LSST Camera on the telescope mount.

The M2 mirror figure was measured with the mirror in its cell and supported by the mirror support system facing down (as it will be in the Simonyi Survey Telescope). An interferometric method was developed specifically for this purpose to verify the image quality requirements.

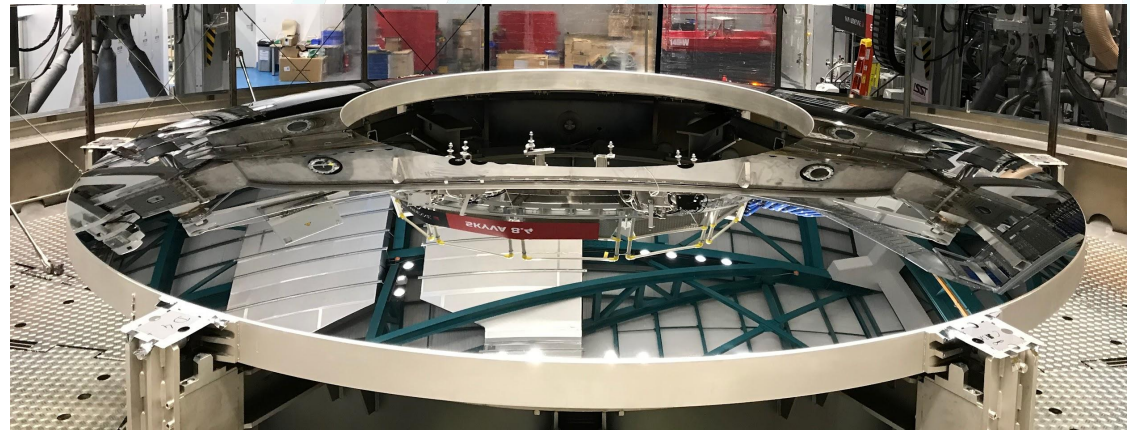

Clean Room

Status: Cleaned and operational since June, 2019

Size: Clean Room ~60 square meters (~197 square feet),

White Room ~ 65 square meters (~213 square feet)

The Camera Clean Room, an ISO 7 clean room (class 10,000), was built on the maintenance floor of the Rubin Observatory summit facility. It is the area where the Rubin Observatory LSST Camera will be assembled and tested on a large support stand. Activities planned for this room include optical realignment of the lens assembly to the focal plane, and integration of the Commissioning Camera (ComCam) and then the LSST Camera with the Top End Assembly (hexapod and rotator). During Operations, this room will be used if it is necessary to change out one of the science rafts in the LSST Camera.

The Camera White Room is an ISO 8 clean room (class 100,000) attached to the Clean Room. This room has already been used for activities including running the test refrigeration system (Refrigeration Pathfinder) and assembling the Refrigeration Pathfinder onto the ComCam. It will also be used for testing and reinstalling the front lens assembly (shipped separately) onto the LSST Camera when both pieces are on the summit in 2023, storing optical filters, and performing maintenance on the shutter and auto changer (there are two of each of these, and they will be switched out each year) during Operations.

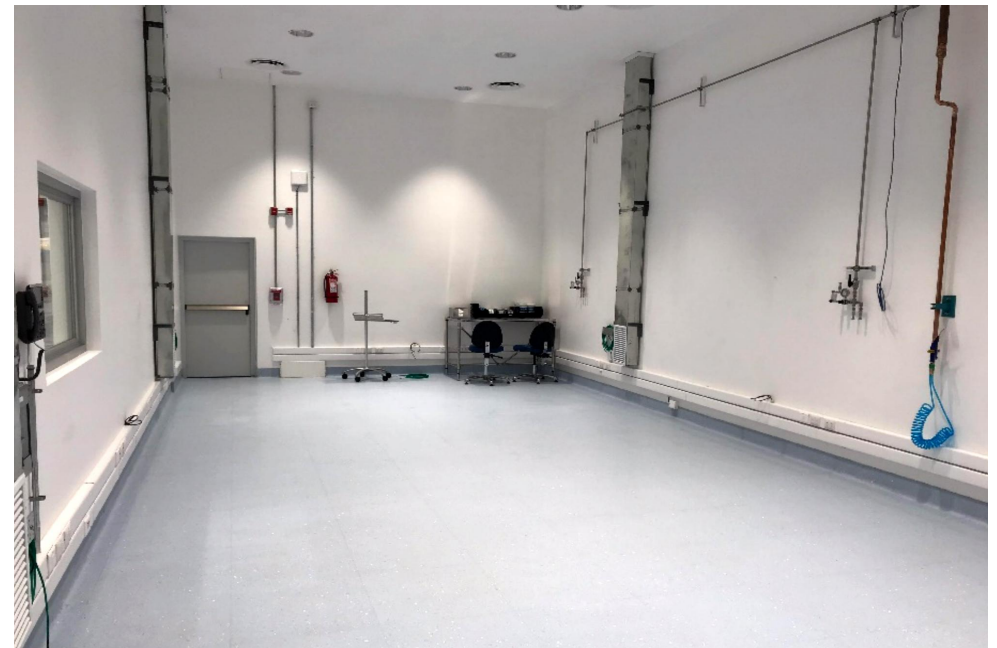

Vertical Platform Lift

Manufactured by: PFlow Industries

Status: Complete and operational since April 2019

Maximum lift weight: 94 tons (85.5 metric tons)

Carriage size: ~33-foot square (~10-meter square) platform

The vertical platform lift (often referred to as the Pflow lift) will carry the assembled mirror and camera subsystems 78 vertical feet (23.8 meters) between the Simonyi Survey Telescope and the maintenance floors of the Rubin Observatory summit facility. The heaviest load to raise and lower will be the combined weight of the Primary Tertiary Mirror (M1M3), mirror cell, and transport cart—close to 80 tons (72.5 metric tons).

The lift, custom-made for Rubin Observatory, allows the carriage to travel all the way up to the eighth level of the building: the telescope floor. The lift-up roof weighs about 15 tons (13.5 metric tons), and rises 25 feet (7.6 meters) higher than the top of the shaft. In its highest position the lift carriage would obstruct the rotation of the telescope dome, which is why the roof wasn't installed permanently at this height—when the lift carriage is lowered, the roof section also lowers and securely locks in place clear of the rotating dome.

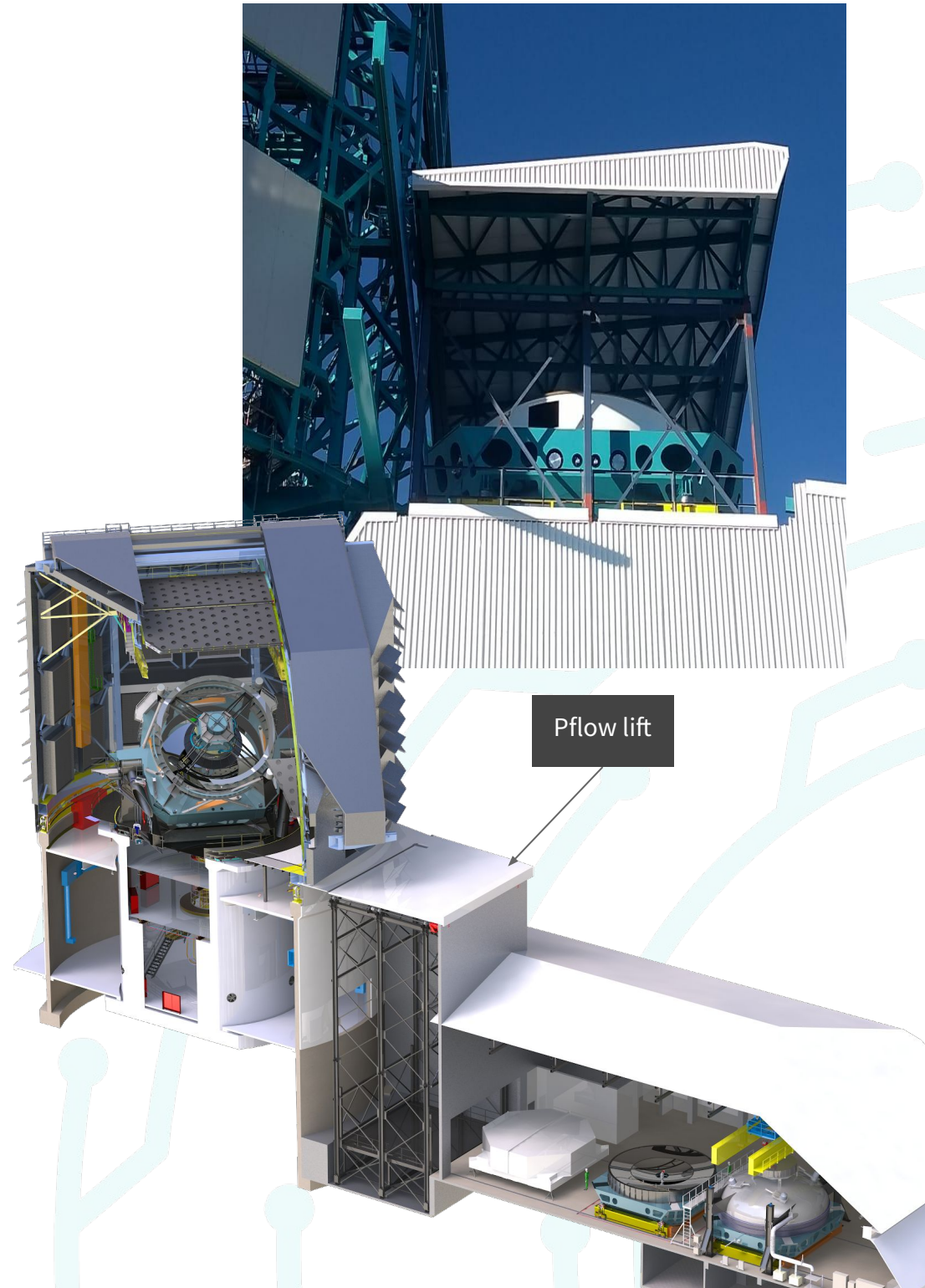

Dome

Manufactured by: EIE and Rubin Observatory on Cerro Pachón

Status: Nearing completion

Size: ~ 27 meters high, ~30 meters in diameter

The Rubin Observatory Dome includes not only all the rotating components, but also the drive system with capacitor energy storage, brake system, slip ring system and locking mechanism. It also includes the control/interlock system, and the track system on which its bogies ride. The separation between the facility and the dome is the top of the concrete lower enclosure on which the bogie track and drive units are installed.

Because Rubin Observatory has a wide field of view, its optical system is unusually susceptible to stray light. As a consequence, the dome not only protects the Simonyi Survey Telescope from the environment but also provides critical light baffling. All dome vents are covered with light baffles which simultaneously provide both essential dome flushing and stray light attenuation. The wind screen also (and primarily) functions as a light screen, providing only a minimum clear aperture. Since the dome must operate continuously, and the drives produce significant heat, they are located on the fixed lower enclosure to facilitate glycol water cooling. To accommodate daytime thermal control, a duct system channels cooling air provided by the facility when the dome is in its parked position.



Telescope Mount Assembly (TMA)

Manufactured by: Empresarios Agrupados (EA), Spain

Status: Arrived on the summit in September 2019

The Simonyi Survey Telescope at Rubin Observatory includes the Telescope Mount Assembly (TMA). This is the structure that supports the Primary/Tertiary Mirror (M1M3) cell assembly, the Secondary Mirror (M2) cell assembly, the LSST Camera, baffles, and the integral subsystems required to operate the telescope.

A variety of organizations worked together to design and build this large and complex structure. The TMA was designed by GHESA Ingeniería y Tecnología, S.A. It was constructed at Asturfeito, S.A, in northern Spain. The design of the mount control, camera cable wrap, and mirror covers is by IK4 Tekniker. The design and fabrication of the azimuth and elevation linear drives and capacitor bank is by Phase Motion Control.

After its completion in 2019, the TMA was disassembled in Spain and shipped to Chile. Now that it's onsite at the Rubin Observatory summit facility on Cerro Pachón, personnel from GHESA and Asturfeito are reassembling the TMA on the telescope pier in the Rubin Observatory facility.

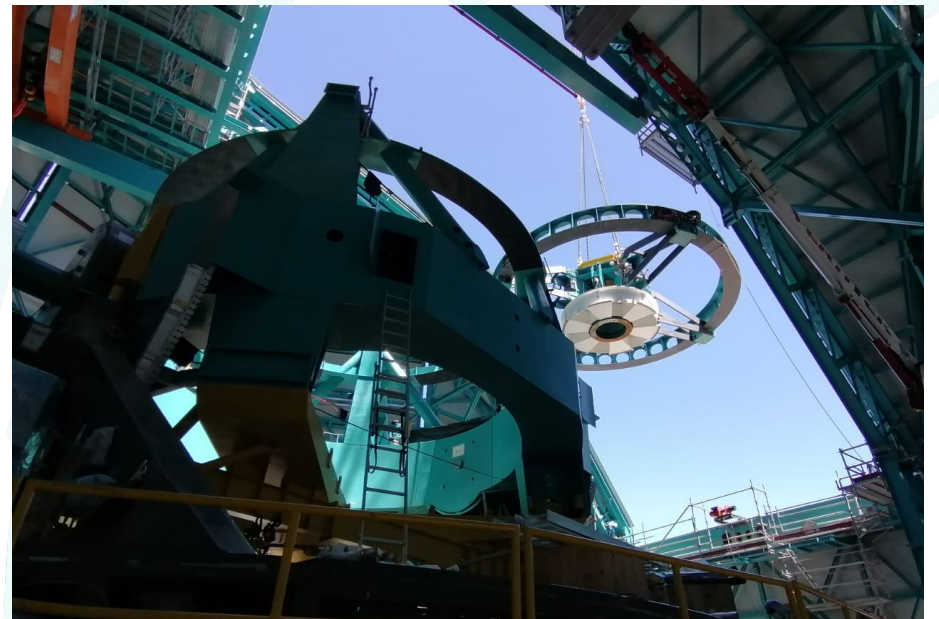
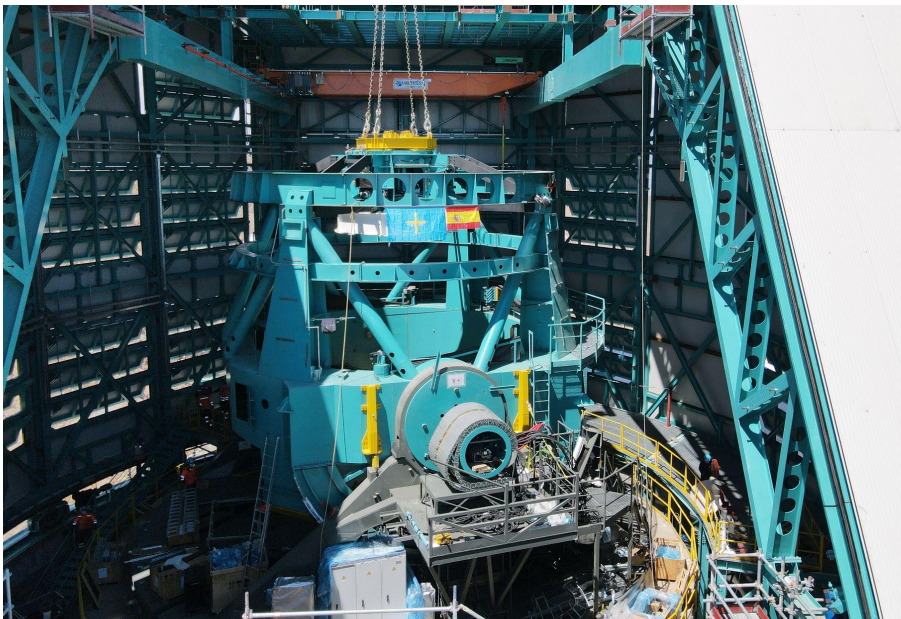
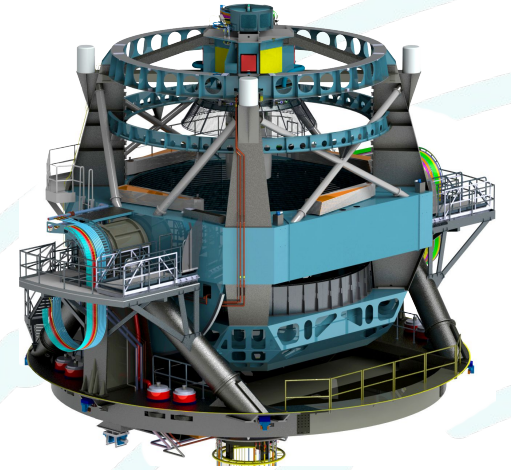

Rubin Observatory LSST Camera

Manufactured by: SLAC National Accelerator Laboratory, with funding from the US Department of Energy

Status: Major components integrated at SLAC, scheduled to ship to Chile in 2023

Size: ~1.65 m (5.5 ft) x ~3 m (9.8 ft)

Weight: ~2800 kg (6200 lbs)

The Rubin Observatory LSST Camera is the largest digital camera ever constructed, roughly the size of a small car. It is a large-aperture, wide-field optical imager capable of viewing light from the near ultraviolet to near infrared ($0.3\text{-}1\ \mu\text{m}$) wavelengths. The camera is designed to provide a 3.5-degree field of view, with its $10\ \mu\text{m}$ pixels capable of 0.2 arcsecond sampling for optimized pixel sensitivity vs pixel resolution.

The image surface is flat with a diameter of approximately 25.2 in (64 cm). The detector format employs a mosaic of 189 16-megapixel silicon detectors arranged on 21 "rafts" to provide a total of about 3.2 gigapixels. The camera includes a filter-changing mechanism and shutter. It is positioned in the middle of the telescope where cross sectional area is constrained by optical vignetting (edge darkening) and heat dissipation must be controlled to limit lens-deforming thermal gradients in the incoming light.

The Rubin Observatory LSST Camera will produce data of extremely high quality for the Legacy Survey of Space and Time with minimal downtime and maintenance.

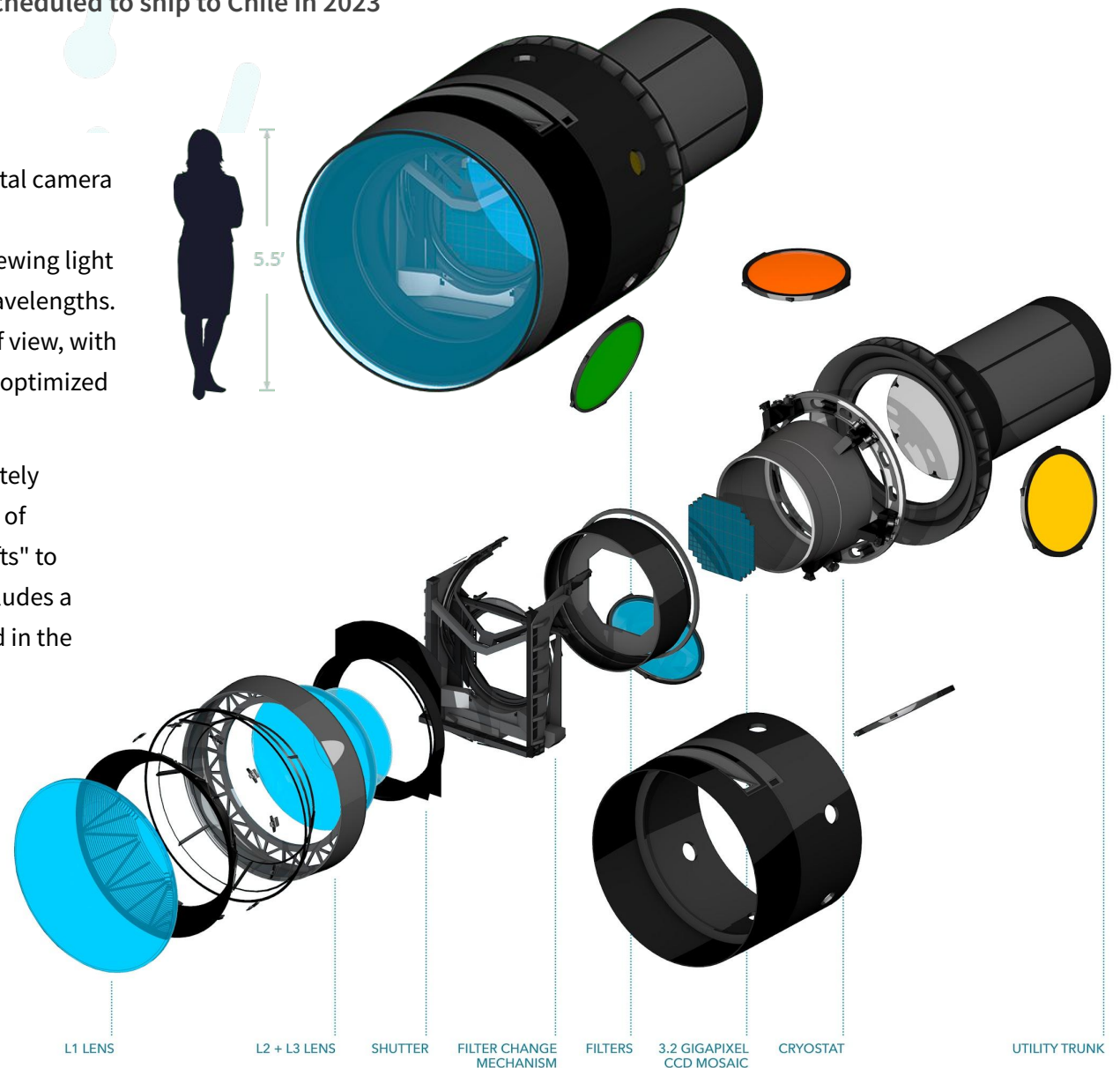

Auxiliary Telescope

Status: Installed and undergoing commissioning on Cerro Pachón

The 1.2-meter Auxiliary Telescope (AuxTel), a gift from Edgar Smith, is an existing telescope that was repurposed for its role in the Rubin Observatory Legacy Survey of Space and Time. It was relocated to Cerro Pachón from its original location on Kitt Peak, near Tucson, AZ, after being refurbished at Rubin Observatory headquarters.

The AuxTel measures atmospheric transmission, which refers to how directly light is transmitting through the Earth's atmosphere in a given spot, as opposed to being absorbed or scattered. Because the presence of certain molecules and particles in the atmosphere will change the color of light detected by the Rubin Observatory Simonyi Survey Telescope, data collected by the AuxTel, as it mirrors the nightly movements of the main telescope, will inform the catalog corrections that need to be made to Rubin Observatory Legacy Survey of Space and Time data in order to render it more accurate.

The Auxiliary Telescope is located on a hill about 100 meters (328 feet) from the Rubin Observatory.

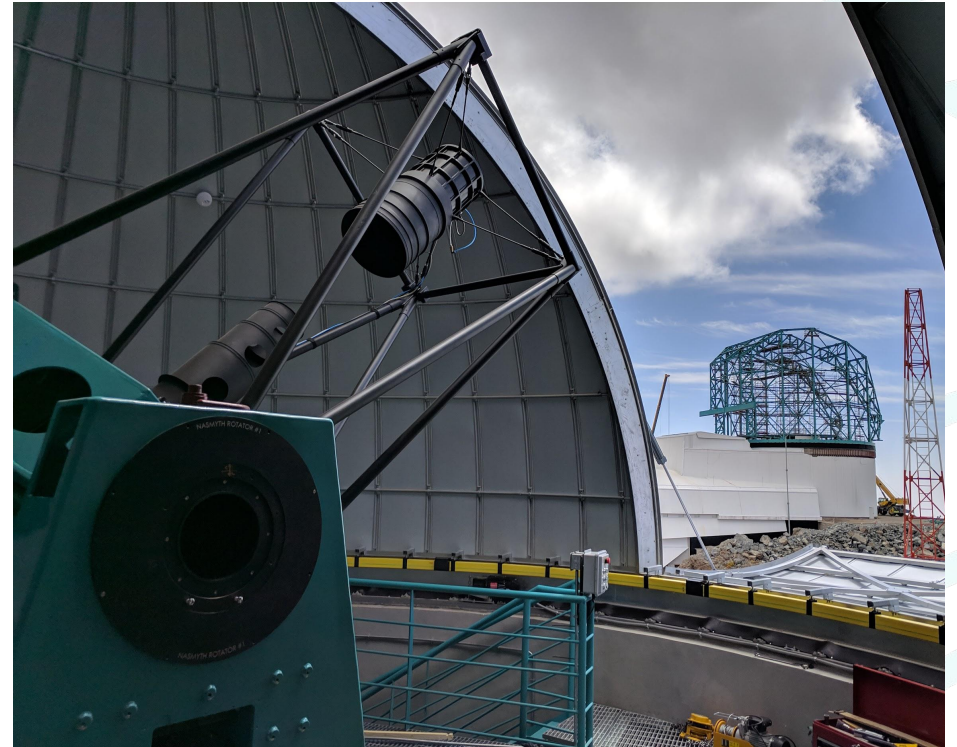



Description: The LSST Camera team successfully completed the lift of the cryostat and installation into the camera body on April 8, 2022.

Location: SLAC National Accelerator Laboratory

Credit: Jacqueline Ramseyer Orrell/SLAC National Accelerator Laboratory



Vera C. Rubin Observatory, March 2022



Vera C. Rubin Observatory is a Federal project jointly funded by the National Science Foundation (NSF) and the Department of Energy (DOE) Office of Science, with early construction funding received from private donations through the LSST Corporation. The NSF-funded LSST (now Rubin Observatory) Project Office for construction was established as an operating center under the management of the Association of Universities for Research in Astronomy (AURA). The DOE-funded effort to build the Rubin Observatory LSST Camera (LSSTCam) is managed by SLAC National Accelerator Laboratory (SLAC).

NSF and DOE will continue to support Rubin Observatory in its operations phase to carry out the Legacy Survey of Space and Time.

They will also provide support for scientific research with the data.



U.S. DEPARTMENT OF
ENERGY

SLAC

CHARLES AND LISA SIMONYI FUND
••• FOR ARTS AND SCIENCES •••

LSST
CORPORATION