



NATIONAL OPTICAL ASTRONOMY OBSERVATORY

Cerro Tololo ● Kitt Peak ● U.S. Gemini Program

NATIONAL SOLAR OBSERVATORY

GONG ● Kitt Peak ● Sacramento Peak

Newsletter 65

March 2001

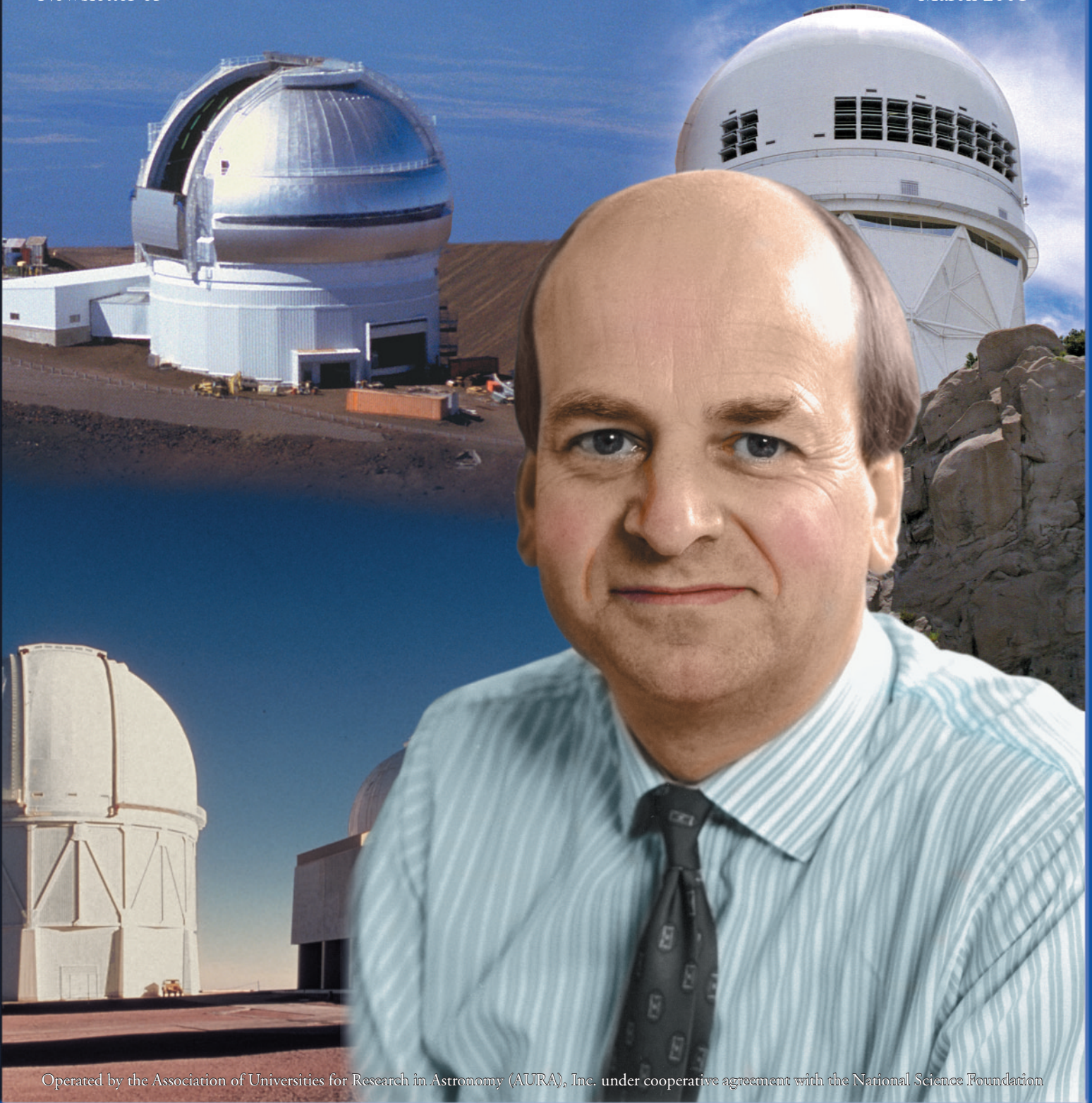



IN THIS ISSUE



Director

Jeremy Mould Selected as NOAO Director

William Smith, President of AURA, announces the selection of Jeremy Mould as the next NOAO Director. Dr. Mould writes that he is excited to be leading NOAO to realize the vision of the McKee-Taylor Decadal Survey. [Page 7]

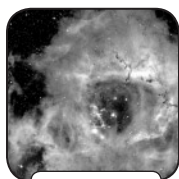

Programs

Observing Proposals Due 31 March

Information is given for observing proposals for facilities available through NOAO—Gemini North and South, CTIO, KPNO, and NSF-sponsored time on the MMT and HET. [Page 17]

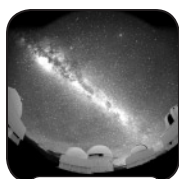

CTIO

Site Survey Begins for the GSMT

AURA has established a site survey team as part of the conceptual design work on the Giant Segmented Mirror Telescope being carried out by its New Initiatives Office. The site survey team reports on their first trip to the Atacama Desert in northern Chile. [Page 23]



NSO

Users' Committee Report and new DST Spectropolarimeter

The NSO Users' Committee praised the NSO staff for the remarkable progress on projects that benefit the user community. [Page 51] One of these is a collaboration between HAO and NSO for a new spectropolarimeter for the Dunn Solar Telescope, to replace the HAO/NSO Advanced Stokes Polarimeter which has been one of the most successful instruments on the telescope over the past decade. [Page 52]

ON THE COVER

Jeremy Mould, new NOAO Director

Jeremy Mould has been selected as the next director of the National Optical Astronomy Observatory. Formerly a staff member of KPNO, he has been a user of NOAO facilities over the past 25 years.

Dr. Mould comes to NOAO from the Australian National University, where he was the Director of Mount Stromlo and Siding Spring Observatories. He was one of the leaders of the team for the HST Key Project on the extragalactic distance scale.

The NOAO-NSO Newsletter is published quarterly by the *National Optical Astronomy Observatory*
P.O. Box 26732, Tucson, AZ 85726

STAFF

Bruce Bohannon, *Editor*

Section Editors

Bruce Bohannon	KPNO
Dave Bell	Observational Programs
Doug Isbell	Public Affairs and Educational Outreach
Tod R. Lauer	Highlights
John Leibacher	NSO & GONG
Knut Olsen	CTIO
Priscilla Piano	NSO & GONG
Caty Pilachowski	USGP
Bob Schommer	USGP

Production Staff

Sally Adams	Copy Editing & Production Management
Mark Hanna	Digital Processing
Pete Marenfeld	Design & Layout
James Rees	Mailing
Phil Sharpley	Printing & Mailing

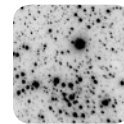

TREASURE HUNT IN THE SUN'S NEIGHBORHOOD

Based on a Contribution Solicited from Todd J. Henry (Georgia State)

Todd Henry (Georgia State), Phil Ianna (Virginia), and Rene Méndez (ESO) used the 0.9-m and 1.5-m telescopes at CTIO to discover five new star systems, one of them a triple, lying only 7 to 15 pc away. These seven stars are the first results from CTIOPI (Cerro Tololo Interamerican Observatory Parallax Investigation), a three-year project to determine parallaxes for stars lurking undiscovered in the solar neighborhood, carried out under the auspices of the NOAO Survey Programs. Each of the new discoveries provides a fresh target for planet hunters and, eventually, for astronomers searching for signatures of biological activity on those planets.

All of the new discoveries are M2 - M5 red dwarfs in the southern sky, where historically research on nearby stars has been less extensive than in the north. Although they are among the nearest few hundred star systems, these five have been overlooked due to their low luminosities.

The nearest of the new neighbors is LHS 3746, a small ember of a star only one-third the mass and diameter of the Sun, emitting less than 1% of the Sun's light. With a distance of only 7.6 pc (parallax of 0.1322 ± 0.0074 arcsec), it is the 113th nearest system. It is the newest member of the 10 pc RECONS sample established by Henry, which now includes 316 objects in 228 systems.

These new solar neighbors are merely the first wave of results from a large effort that will determine distances to 250 nearby star systems. During the three-year duration of CTIOPI, which was awarded four nights on the 0.9-m and two nights on the 1.5-m each month, nearby stars are identified as those tracing out

serpentine paths on the sky relative to more distant stars. The length of the path is determined by the star's proper motion and its wiggle by its parallax. At present, there are more than 150 systems on the program at the 0.9-m (6.8' field using the central 1K of the CCD) and nearly

continued

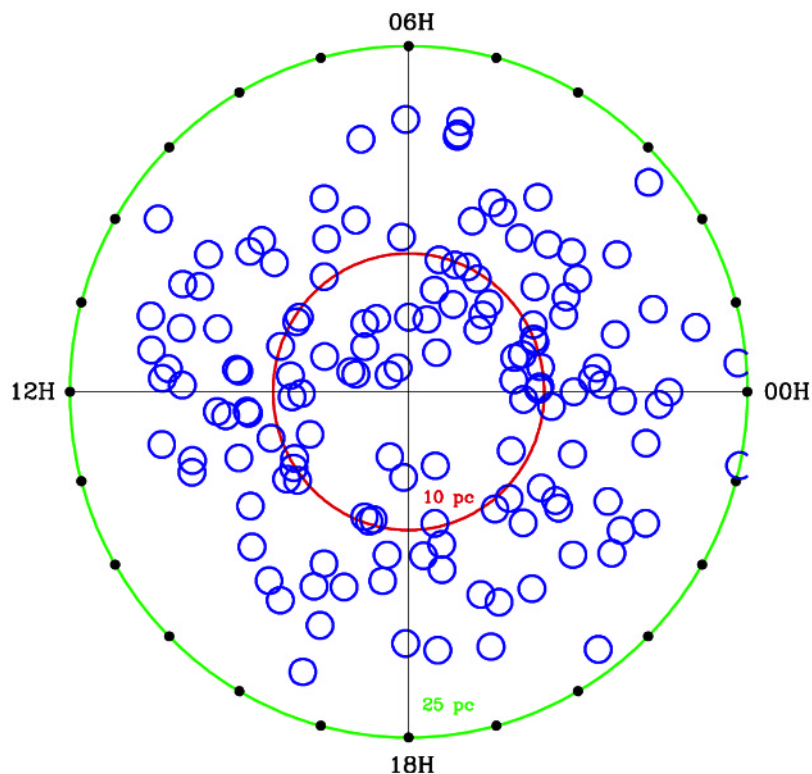

CTIOPI candidates for nearby solar companions are plotted as a function of right ascension and distance from the Sun. A total of 158 systems are on the program as of January 2001: 45 systems possibly within 10 pc, 99 systems possibly between 10 and 25 pc, 3 systems probably beyond 25 pc, and 11 systems with no distance estimates.

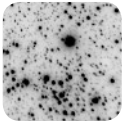

Highlights

Treasure Hunt continued

100 more on the 1.5-m (8.2' field using the entire CCD). Due to good weather, reliable telescopes, sensitive CCDs, and superb support at CTIO, CTIOPI is on track to exceed its goal of determining parallaxes better than 3 milliarcseconds (mas) for 150 systems. These first, albeit preliminary, parallaxes have errors of 2.3 to 7.4 mas using only 16 months of data (rather than the ultimate 36 months), and typically only half of the total number of frames anticipated (about 40) for 3 mas precision. Henry, Ianna, and Méndez are encouraged by the success rate for these first targets—five for five within 15 pc (let alone the goal of 25 pc) is an excellent start.

Target systems—white, red, and brown dwarfs with R magnitudes between 10 and 20—have been selected from a variety of sources. Proper motion candidates are chosen from the historic Luyten and Giclas surveys, for which 15% of systems with proper motions in excess of 1"/year have no parallaxes at all. In addition, several new proper motion surveys that illustrate the international flavor of nearby star work have provided new candidates, including several from Wroblewski et al. (Chile), Scholz et al. (Germany, United Kingdom), Méndez et al. (Chile, United States), and Ruíz et al. (Chile). Photometric candidates are chosen from the extensive published work of Weis (United States) and from the historical archives of Jahreiss (Germany), who has been generous in providing targets with unpublished data. Recently, several brown dwarf candidates (many of which are not yet published) have been provided by Delfosse of the DENIS team. There are also a few dozen targets

continued

First Data Release from the NOAO Deep Wide-Field Survey

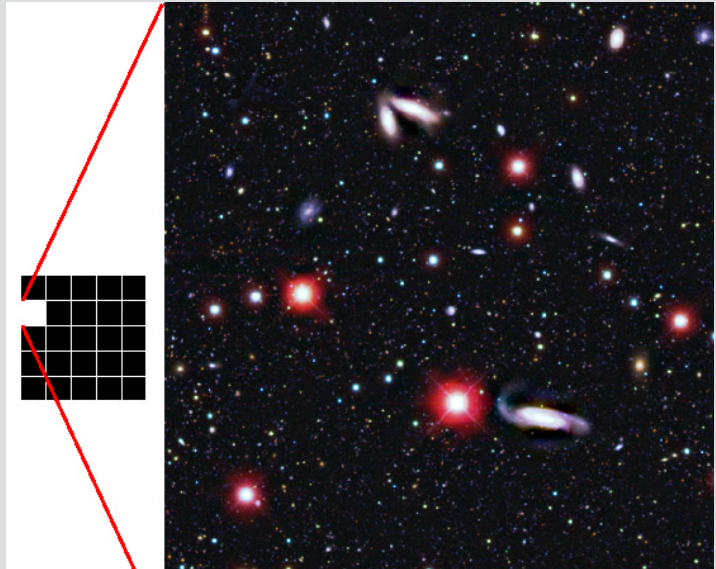

The NOAO Deep Wide-Field Survey is a deep optical and near-infrared imaging survey that will sample the sky in two 9-square-degree fields. The survey is designed to investigate the existence and evolution of large-scale structures at redshifts $z > 1$ and study the evolution of galaxy populations out to redshifts of $z \sim 4$. In addition, the survey will provide the astronomical community with a sensitive multicolor database from which samples may be selected for the study of a host of other interesting astronomical problems.

The Bw-, R-, and I-band images, which are roughly centered on J2000 14h 27m +35° 14', are now available at <http://archive.noao.edu/ndwfs/>.

The first release of data from the NOAO Deep Wide-Field Survey, which covers a 1.2 degree square, is a sub-set of the 3° × 3° survey field at high galactic latitude ($b=67^\circ$). Roughly 300,000 galaxies and stars are detected in the images, which have a 5 σ detection limit in all bands close to 26th mag (AB).

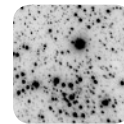

Treasure Hunt continued

that are being observed intensely for perturbations caused by unseen companions, a classic astrometric experiment that has not been done for southern sky targets. When combined with data from Ianna's long-term Australia program, companions of brown dwarf mass with orbital periods of a decade might be revealed.

At present, there are roughly 2100 systems known closer than 25 pc, the distance limit of a sample of stars being studied in great detail by NASA's Nearby Stars (NStars) Project. CTIOPI hopes to increase that number by 10% or more. NStars is part of a long-term initiative to promote research on nearby stars from both the ground and space,

including work on fundamental stellar quantities, stellar populations and kinematics, history of the galaxy, extrasolar planets, habitable zones, and the search for life elsewhere. NASA and the NSF have collaborated to support the effort. Goals include providing a robust, Web-based data set for use by researchers and the public regarding stellar objects within 25 pc of the Earth; characterizing stars especially in terms of astrobiology-related properties such as age, metallicity, variability, substellar companions, and circumstellar planetary "exozodi" dust; and supporting definition of research programs using upcoming NASA Origins facilities such as SIRTf (Space Infrared Telescope Facility), SOFIA (Stratospheric Observatory

for Infrared Astronomy), SIM (Space Interferometry Mission), and TPF (Terrestrial Planet Finder).

It is anticipated that there will be more than 10,000 stars, brown dwarfs, and planets within 25 pc when the NStars sample is complete. These are the stars that offer the best promise for answers to questions about the census of the Sun's neighbors, how many stars have planets circling them, and whether or not any of these planets harbor life. In order to have the best sample possible to answer these questions, CTIOPI hopes to discover a lot of hidden treasure and to make a significant contribution to the neighborhood.

Solar Magnetic Fields—Application of Adaptive Optics Offers New Insights

Michael Sigwarth and Thomas Rimmele

The NSO low-order adaptive optics system at the Dunn Solar Telescope (DST) has made it possible to obtain the first high-resolution and low-noise Stokes spectra of identified individual flux tubes in the solar magnetic network. Flux tubes are the smallest, intense flux concentrations known in the solar photosphere. Because of their large numbers, they contribute significantly to global solar phenomena. In the G-band at 430 nm, flux tubes become

visible as bright points. The typical sizes of such bright points range between 150 to 300 km in diameter.

We used the HAO/NSO Advanced Stokes Polarimeter (ASP) to investigate magnetic fields in the quiet Sun network and internetwork. High-resolution images in the G-band were obtained simultaneously. Bright points, visible in the high-resolution images, could also be identified in the Stokes spectra. AO allowed the

increase of integration time of the polarimetric measurements to 4.2 seconds and enhanced the signal-to-noise ratio while the spatial resolution was still limited by the ASP pixel size of $0.4'' \times 0.4''$.

It was also possible to measure for the first time the field strength of an identified individual flux tube to 0.1 ± 0.01 T. The flux tube itself remained spatially unresolved, but

continued

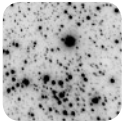

Highlights

Adaptive Optics continued

the analysis of individual Stokes-V spectra suggests that the flux tube is embedded in a much weaker and probably turbulent magnetic field. The source of this field could be a turbulent field generated locally by granular flows, “recycled” magnetic flux from dissolved active regions, or returned flux from the flux tube itself.

A new Stokes polarimeter that is currently under construction for the DST (see article in this newsletter) will allow better use of the high resolution that AO provides and will enhance the capability to obtain more detailed information on the structure of flux tubes and the weaker magnetic fields in the solar photosphere.

The NSO AO System was described in *NOAO Newsletter* 56 (p. 36). For additional information, see <http://www.sunspot.naoa.edu/AOWEB/>.

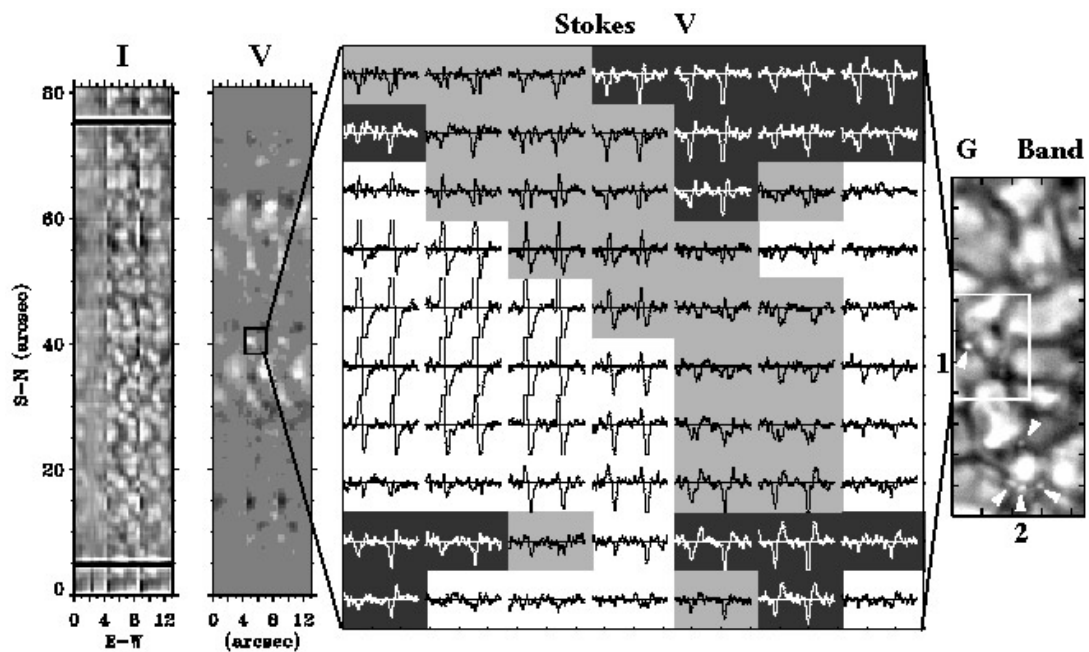

Stokes-V spectra in the area of a magnetic flux tube in the solar magnetic network. The G-band image (right) shows an individual bright point [1] and a group of bright points [2] within the granulation. The area within the white rectangle is represented by the spectra plotted in the middle square: white background indicates positive polarity (or no signal); black background, negative polarity; and gray background, weak and complex profiles. Large amplitude Stokes-V profiles are located at the position of the bright point. These points are surrounded by very faint signals,

which indicate a weaker field around the intense flux tube. The continuum intensity [I] and Stokes-V amplitude maps obtained from three spatial scans with the Advanced Stokes Polarimeter are shown on the left. The interference of signals from the flux tube and an opposite polarity field in the upper left corner could be the reason for the complex profiles in between them. For the first scan, the AO was not correcting the wavefront aberrations. The investigated area is within the black square.

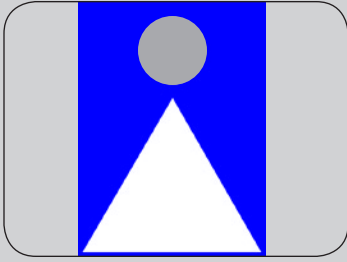

Director's Office

From the AURA President

William Smith

This edition of the *NOAO Newsletter* comes at a propitious time. Over the past year, AURA has embarked on an intensive effort to identify and recruit a new director for NOAO. Given Sidney Wolff's distinguished leadership and impressive record of accomplishments, this search has been a difficult one. I am pleased to say that our efforts have produced an outstanding success in the selection of Jeremy Mould.

Jeremy Mould has been closely associated with AURA and with NOAO for more than a decade. Not only does he bring a world-class scientific reputation, he has a long track record as an observatory director and as an outstanding manager. AURA is extremely fortunate to have Jeremy's services at this critical time in NOAO's future.

The AASC Decadal Survey has articulated a bold—and very different—vision for NOAO and the role of a national observatory. It is clear that NOAO staff have in fact heavily contributed to this vision and thus have already demonstrated their commitment to achieving it. Jeremy Mould's leadership will be a crucial

continued

Back to the Future

Jeremy Mould

I am rejoining the National Optical Astronomy Observatory very conscious of the honor of being invited to lead the observatory by AURA in its role representing the national astronomical community, and very excited about the years ahead. The excitement comes from a far-sighted decade plan, *Astronomy & Astrophysics in the New Millennium*, which the community has made, and in which NOAO is challenged to play its part.

The Survey Committee sees the astronomy community creating the needed new facilities cooperatively, while retaining the full power of the diversity which has made US astronomy so successful. NOAO is asked to make this its agenda, not from a position of strength, but from a peer position. This is an attractive vision to many of us, but it is not an easy one to realize, and we can't afford the luxury of a lot of redundancy in the system. The requirements placed on NOAO are many, but a core responsibility is some access to unique facilities by proposers on the basis of simple merit.

Since the release of the decade plan, NOAO has been a hive of activity examining initiatives which it might facilitate in partnerships (such as LSST and GSMT) and ways of enhancing what it is already doing (such as archiving). This will continue through the first



Jeremy Mould has been selected as the new NOAO Director

half of this year, culminating in the submission of AURA's proposal to the National Science Foundation to continue managing NOAO. I am coming on board at a critical time, and a key role for me is to help find the balance between resourcing the existing facilities, whose research output is impressively productive, and the strategic development of NOAO's part in the system which we need to have in ten years' time. I'm looking forward to working with you all.



AURA continued

element in making this vision a true success. Beginning in February, Jeremy will undertake an aggressive effort to examine every facet of NOAO and every possible way in which NOAO can lead in implementing the Decadal Survey. This transition effort will be made all the more difficult by the prospect of the recompetition that will be held for AURA's managing role for NOAO over the next year.

This effort will be difficult but will yield long-lasting benefits for NOAO and for the astronomy community. It will put in place the necessary structure we so much need for the coming decade. I urge all NOAO staff to cooperate fully with Jeremy in this undertaking and to lend him your strong support. I look forward to a dynamic and prosperous future for NOAO under Jeremy's leadership.

Sidney Wolff: Architect of the Future

Sidney Wolff is stepping down after more than 13 years as the Director of NOAO. Her legacy will be a new generation of national telescopes, a changed paradigm for the National Observatory, and a visionary blueprint for the future of ground-based optical and IR astronomy.

Sidney's unique combination of vision, persistence, eloquence, and high ethical standards were key to the success of a series of major initiatives.

She helped forge the WIYN consortium, which created a modern telescope that utilizes a mirror derived from NOAO's participation in development of the Steward Mirror Lab. The project was successful in several ways. It resulted in an excellent telescope that improved on the ground-breaking design of ARC and that validated the performance of borosilicate mirror technology. It proved that NOAO could work effectively in a complex partnership with universities. The use of active mirror support and thermal control laid the groundwork for Gemini and other large-aperture telescope designs. The consistent sub-arcsecond delivered image quality reminded the community that Kitt Peak remains a world-class site.

Sidney supported the innovative proposal from the National Solar Observatory and its community to develop the GONG project. That support came in the form of key technical resources and deft, often unappreciated allocation of finances to the project, sometimes in the face of sharp budget cuts.



Sidney Wolff, in her more than 13 years as NOAO Director, transformed mountaintops, her staff, and the national dialogue on ground-based O/IR astronomy

She launched the Gemini project by skillfully blending the growing support for high-performance large-aperture telescopes with the NSF's interest in international partnerships. As the first Gemini director, she assembled a project team focused on excellence and composed of the best from partner observatories and from industry. Her principled firmness guided the project through the turmoil of the primary mirror decision process and placed it firmly on the path toward completion within schedule and budget.

Sidney also backed the National Solar Observatory's initiatives for SOLIS and the Advanced Technology Solar Telescope by assigning a strong technical staff and by re-balancing solar and nighttime resources to reflect the evolving priorities of AURA and of NSF.

continued



Sidney Wolff continued

She facilitated and shaped the SOAR partnership to achieve the aspirations of its partners for a state-of-the-art 4-meter telescope in the south.

She was instrumental in the formation of the ACCORD consortium, where her patient and constructive approach engaged other major observatory directors in a productive and continuing dialogue on the complementary roles of public and independent observatories.

Her vision for the next decade anticipated and shaped the recommended roles for the new NOAO that appear in the McKee-Taylor Decadal Survey, *Astronomy and Astrophysics in the New Millennium*.

All of this was accomplished while she continued to ably direct the ongoing operations of NOAO at all of its diverse sites, interact with numerous oversight committees, and effectively represent NOAO to the funding agencies and to the community at large. Throughout these varied and often difficult activities, Sidney retained her essential warmth, humanity, and accessibility.

Sidney Wolff transformed mountaintops, her staff, and the national dialogue on ground-based O/IR astronomy during her tenure as NOAO Director. We are in her debt for her effective stewardship of national assets that created a new era of scientific opportunity for the nation's astronomers.

*Richard Green and Dave DeYoung,
for the NOAO Staff*

The First Workshop on the Ground-Based O/IR System: Report Now Available

Todd Boroson

The "First Workshop on the Ground-Based O/IR System" was held 27–28 October 2000 in Scottsdale, Arizona. This workshop, attended by 80 astronomers from 45 different institutions, was the community's first opportunity to explore the implications of the recommendation of the McKee-Taylor Decadal Survey, and of the O/IR panel in particular, that the ground-based O/IR capabilities be viewed as a system. This perspective arises from the consideration that the US position will remain competitive and effective only through investment that recognizes the way in which public and private facilities together provide the resources that the community needs to carry out research. The goal of the workshop was to engage a broad segment of the community in discussions about the

context and elements of the ground-based O/IR system and, through science-based arguments, to identify capabilities that might be missing or in short supply.

The report from this workshop is now available on the NOAO Web site at http://www.noao.edu/gateway/oir_workshop/report.pdf. The report includes a summary of the workshop activities, instrumental and other capabilities that are considered to be of high priority, and recommendations by the organizing committee. Appendices include the list of participants, the workshop agenda, reports of the six science-based breakout groups, and a set of tables presenting existing and planned capabilities on medium- and large-aperture telescopes.



“Science with LSST”—A Report on the Workshop

Todd Boroson

The Large-aperture Synoptic Survey Telescope (LSST) is a wide field-of-view facility that will repeatedly image the entire visible sky to substantial depths, opening up the time domain for studies of moving, transient, and variable objects. In addition, LSST will build up a static data set that will support studies requiring deep imaging over substantial fields or even the entire sky. LSST was given strong endorsement by the recent McKee–Taylor Decadal Survey, based on the potential of the LSST to make essential contributions to the search for earth-crossing asteroids, the discovery of Kuiper Belt objects, observations of supernovae, and the mapping of dark matter through weak lensing. LSST is envisioned to work in a mode unlike any existing telescope. It will perform a series of pre-programmed observations, with the goal of simultaneously addressing a number of important scientific problems. Data will be immediately released publicly, in order that follow-up observations of time-critical phenomena can be undertaken.

To further develop the performance requirements for the LSST system and to explore the constraints placed on the operations strategy by various scientific programs, a community-based workshop, “Science with LSST,” was held 17–19 November

2000 at NOAO in Tucson. In attendance were 55 participants from 22 different institutions. The agenda and list of participants can be found on NOAO’s web site at http://www.noao.edu/gateway/lst_workshop.

Following a series of presentations that laid out straw man concepts for the telescope, the instrument, and the data system, and discussed issues relating to photometry and astrometry, breakout groups explored potential LSST science in four categories: (1) objects moving at non-sidereal rates, e.g., NEOs and KBOs; (2) transient or variable objects, e.g., supernovae, GRBs, microlensing events, and variable stars; (3) whole-sky imaging, e.g., stellar population studies in the Milky Way or nearby galaxies; and (4) ultra-deep imaging, e.g., mass tomography through weak lensing. Groups with expertise in each of these categories discussed the specific projects that LSST could undertake and developed a list of requirements in areas such as delivered image quality, astrometric precision, bandpass, and site characteristics. In addition, each group laid out its desires for operation, including exposure time, observation cadence, and requirements for data processing and follow-up observations. A final plenary session brought all these constraints and ideas together for a discussion of general conclusions and issues for further study.

It was agreed that LSST can address a broad range of important scientific questions by operating in two modes that are interwoven. Some fraction of the time (likely 50% or more) will be spent imaging the entire sky to a modest depth ($m=24$ in 20–30 second exposures) with a complex series of “revisit intervals” and filters. These exposures will also serve to generate a deep multicolor image of the entire sky that will form the principal data set that the broadest segment of the community will want. The rest of the time will be used to obtain much deeper images of a set of smaller fields in a few bandpasses. These exposures will be taken with a specified set of intervals to enable searches for much fainter variable objects.

The desirability of an LSST-precursor experiment was also acknowledged. Since both the data rate and the data volume represent two orders of magnitude increases over the most ambitious ground-based surveys to date, it is imperative that lessons learned from projects such as 2MASS and SDSS be remembered and that new approaches be tested with efforts where less is at stake. Ideas proposed and discussed at the workshop included using a planned 1° field-of-view imager on the WIYN telescope and using the LCO 1.0-m Swope telescope (3° field-of-view) for such an experiment.

continued



Science with LSST continued

A number of other issues were identified as needing further study. These include:

- More detailed development of the NEO observing strategy, including modeling the survey.
- Optimization of techniques for detecting variable or moving objects in crowded fields.
- Modeling observations of extrasolar planet transits.
- Exploration of limitations on photometric precision; better than 0.01 magnitude photometry is needed for some programs.
- Detector issues associated with achieving good sensitivity over the whole of the optical range, and minimizing fringing in the red.
- The manufacture of filters and how they would be changed within the instrument.
- Studies of the spatial and temporal variations of sky brightness in the far red.
- The desirability of auxiliary telescopes that would make simultaneous observations with LSST for calibration.
- A mechanism for ensuring that follow-up observations are made for time-critical applications.

A complete report on the workshop is being written and will be posted on the LSST Workshop Web site at http://www.noao.edu/gateway/lst_workshop/.

NOAO Publication Lists Now Online

The publication lists for KPNO and CTIO going back to 1990 are now posted online at <http://www.noao.edu/noao/library/noapubs.html>. This bibliography tracks publications that have used NOAO facilities as well as publications by the NOAO staff. The lists are ordered by fiscal year (October 1 to September 30).

We invite the community to review these lists and notify us of additions or corrections. Please send your corrections to Mary Guerreri, Librarian (library@noao.edu). As always, we would appreciate receiving preprints of any papers that make use of NOAO data.



Observational Programs

2001B Gemini Proposals

Bob Schommer

We expect that Gemini will issue a call for proposals for both 8-m telescopes by 1 March 2001 for the 2001B (Aug. 2001–Jan. 2002) observing semester. Current predictions suggest Gemini North will be available for slightly more than 50% community science time, and Gemini South for 25% science time in its first semester. The estimated number of nights available to the US community will be detailed in the call for proposals. Instrument deployments are still uncertain at press time, but those that could possibly be available include NIRI, Hokupa'a/QUIRC, and GMOS or OSCIR in the North, and FLAMINGOS I, Phoenix or OSCIR, and the acquisition camera at Gemini South.

The Gemini National Project Offices, including the US Gemini Program, are likely to run a “QuickStart” queue program on Gemini South during the 2001B semester, and no programs will

be scheduled classically. The USGP again plans to run a service-observing “mini-queue” for some fraction of the available time for visitor instruments at Gemini North. Final instrumentation and queue/classical availability details will not be known until late February, so please check our Web site (<http://www.noao.edu/usgp/>) for current information.

When the Gemini call for proposals is released, we will send an announcement to our e-mail distribution list of NOAO proposers and to the AAS Electronic Announcements. If you do not normally receive our direct e-mail announcements and wish to, please send an e-mail to noaomail@noao.edu requesting to be added to the list. The last e-mail announcement was sent in early January concerning letters of intent for Survey Programs.

Keck/NIRSPEC Time Going, Going . . .

Tom Geballe and Marianne Takamiya (Gemini)

Six more nights of observing time on the Keck II Telescope with the Near-IR Spectrograph (NIRSPEC) remain available to the US community (and other Gemini partners), three each in semesters 2001A and 2001B. In Semester 2001A the scheduled nights are 11–13 June. Observations will be carried out by us in queue mode.

Investigators interested in applying for NIRSPEC time should watch the Gemini Observatory Web site (<http://www.us-gemini.noao.edu/sciops/instruments/nirspec/nirspecIndex.html>) for further information. A call for proposals is expected in mid-March, with a due date in mid-April. Please do not submit proposals for 2001A until advised to do so on the Gemini Web site.

NIRSPEC is a near-infrared (1–5 μm), moderate- to high-resolution, cross-dispersed, echelle and grating spectrometer at the Keck Observatory on Mauna Kea. The instrument has recently been outfitted with a new and improved 1024×1024 Aladdin InSb array detector. At any single setting of its grating or

continued

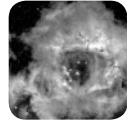

Keck/NIRSPEC continued

echelle, NIRSPEC covers a fractional wavelength range of approximately 0.18. However, except for the shortest wavelengths the echelle coverage is incomplete at any single setting, with gaps that increase with wavelength, so multiple settings must be employed to obtain a continuous high-resolution spectrum over the

wavelength range of 0.18. This and other aspects of NIRSPEC are explained in detail on the Gemini Web pages.

Although the first two observing runs (in 2000) encountered some instrumental problems and some bad weather, excellent data were

obtained for many of the highest ranking proposals. We expect that if the weather is good the success rate will increase, and we look forward to providing additional Keck data to the Gemini community from the final six nights of this program.

The Status of the Hobby–Eberly Telescope

Thomas Barnes (McDonald Observatory)

The HET resumed science operations November 18 and has been operated in science mode with the Low-Resolution Spectrograph (LRS) for two runs since then: Nov. 18–Dec. 2 and Dec. 18–Jan 1. Researchers have commented that HET is now producing better S/N spectra, for a given integration time, than it had in any previous science run. Additional near-term science runs are scheduled for Jan. 17–29, Feb. 14–Mar. 2, Mar. 18–Apr. 1, and Apr. 16–30. These dates are subject to change to accommodate engineering and commissioning tasks.

During the 2001B semester, we estimate that 50 hours of observing time will be available to the national community, with the Low Resolution Spectrometer and the High Resolution Spectrometer available. The Medium Resolution Spectrometer is likely to enter commissioning in this semester. The 50-hour estimate is based upon an assumed 50–75% time assigned to science. A significant amount of time will be devoted to installation and debugging of the primary mirror edge-sensor system in this semester.

Improving the imaging quality at the HET has been our principal priority since last April. Mean delivered image quality of the telescope for the November and December science runs was 2.55" EE50%. This is slightly worse than the 2.37" mean value obtained prior to November, and is likely a result of poorer cold weather seeing. About 16% of the image quality measurements during the November–December period were less than or equal to 2.0" EE50%. Telescope image quality continues to

be limited by dome seeing and misalignment of mirror segments due to temperature gradient effects.

Over the next five months, our image quality improvement plans are the following:

- Characterize and address the observed drift of objects off the LRS slit, despite closed-loop guiding, and check and improve the focus term of the tracker mount model. These two problems are among the highest priority items, as they are believed to be next in importance only to thermal degradation and seeing in establishing the delivered S/N of spectra.
- Complete insulation of one half of the primary mirror truss and test imaging performance. If significant improvement in image quality is observed for the insulated half, the other half of the truss will be similarly insulated.
- Complete design, begin purchase and fabrication of new acquisition camera and guider camera optics.
- Recalibrate the tracker mount model using the new laser alignment system and new focus data.
- Improve tracking and guiding accuracy by moving the rotation point of PFIP to the uncorrected prime focus in software.
- Purchase a glycol chiller and begin design, fabrication, and installation of assemblies for cooling in-dome electronics to improve dome seeing.



HET High-Resolution Spectrograph Status Report

Bob Tull (McDonald Observatory)

The installation and commissioning of the High Resolution Spectrograph (HRS) is proceeding as this article is being written, and we can expect to see the instrument in full operation very soon.

- The Fiber Instrument Feed has been installed, with the input end of the HRS fiber-optic cable in place on the tracker module.
- Daytime skylight illuminating the HET was used to carry out a rough check of focal-ratio degradation of one of the 600- μm fibers. A visual check showed that the focal ratio was at least as good as $f/3.7$ (the goal is $f/4.2$).
- With a photomultiplier in place at the output end of the fibers, a bright star was successively centered on each of three 600- μm fibers. The three fiber ends were, as intended, in a row with 10" separations as seen on the sky.
- True 'First Light' for HRS was observed on the night of 5/6 December. The light of a bright star (Rigel) passed through the entire system and its spectrum was observed visually through the refractive camera.
- The HRS CCD system is now fully assembled and undergoing cryogenic testing and characterization in the Austin CCD laboratory. The cryostat fully meets its specifications.

Installation at the HET is scheduled for late January 2001, with commissioning to begin on-sky January 30. We anticipate starting science with HET-HRS in the late February science run.

Community Access Program Continues on the MMT

Todd Boroson

About 27 classically-scheduled nights per year of observing time on the MMT Observatory 6.5-m telescope are available to the astronomical community through the NOAO proposal process, under an agreement with the National Science Foundation. Proposals for the NOAO 2001B observing semester (1 Aug. 2001–31 Jan. 2002) are due on 31 March 2001 (note that the month of August is traditionally reserved for major telescope maintenance projects). Proposals will be reviewed by the NOAO TAC, and those approved will be forwarded to the MMT for scheduling (approximately 20% more proposals will be forwarded than can be scheduled to allow for block scheduling, conflicts in dates, etc.). Because of the limited support provided by the MMTO, access to the telescope will be restricted to experienced observers. For more information, check NOAO's MMT Web page at <http://www.nao.edu/gateway/mmt/> and MMT's public-access instrumentation page at http://sculptor.as.arizona.edu/foltz/www/public_access.html.

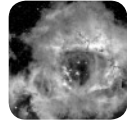

HET Low-Resolution Spectrograph Status Report

Gary Hill (McDonald Observatory)

The Low Resolution Spectrograph (LRS) continues to be used in queue-scheduled operations and is proving to be robust after refurbishments over summer shutdown. We have recently been characterizing the Multi-Object Spectroscopy (MOS) unit for queue use by the Resident Astronomers/Observers. Another key upgrade was to install the Version 2 CCD controller. The new controller takes only 7 seconds to read an acquisition image, compared to 45 seconds before. This huge decrease in time has led to faster setups (10 minutes typically compared to 20 minutes before) and better data quality because the primary mirror segments have less time to unstack.

General Characterization. The goals of the refurbishment were to improve the stability of the long-slit (LS) unit, to complete the calibration system, and to eliminate internal flexure of the LRS as much as possible. These goals were well met: The LS unit now repeats internally to 0.03". The MOS and LS insertions repeat to 0.12".

The MOS unit repeats internally to 0.006". The internal flexure is 0.5 pixels (0.25") peak-to-peak over $\pm 90^\circ$ in position angle, which is completely negligible over a track.

Multi-Object Spectroscopy Unit. The unit is a remotely configurable slitlet unit that is set up using a configuration file uploaded before the observation. The unit is described in Wolf et al. (2000, *Proc. SPIE*, 4008, 216-227). There are 13 slitlets, each about 15" long by 1.3" wide on 20" centers. They can cover 4' in the cross-dispersion direction (along the slits) by about 3' in the dispersion direction (perpendicular to the slits).

The MOS unit is now being used routinely in the science queue by the HET Resident Astronomers/Observers. We do not yet have the final mode of operation where the configuration files can be generated beforehand from astrometry, but we are able to reliably configure the MOS, based on pre-images taken for the PI ahead of the spectroscopic observations.

The biggest restriction on the MOS setup is currently the HET's difficulty in holding image quality as the tracker rotates away from the parallactic angle. This forces us to choose position angles for the observations that are close to parallactic, which restricts the setup and often results in non-optimal setups that miss key targets. We will make the MOS unit available in this mode in the upcoming NOAO 2001B semester on a shared-risk basis, with the proviso that objects must be visible in LRS acquisition images (i.e., be continuum objects with magnitudes brighter than $m \sim 22$). We hope to implement the astrometry-based setup protocol by the end of 2001.

Plans. We have yet to install the SF2 CCD into LRS. This chip has higher QE in the red (1.4 \times better at 700-800 nm) and much better cosmetics than the chip SF1 now in use. We are currently determining when the 15-day downtime needed for the replacement can be fit into the HET operations schedule.

2001B Proposals for the WIYN-Operated 0.9-m Telescope on Kitt Peak

Richard Green

Proposals for the KPNO Mosaic CCD camera on the 0.9-m telescope on Kitt Peak will be accepted for the 2001B semester on a shared-risk basis. For details, please see the accompanying article in the KPNO section of this newsletter.



Four SIRTf Legacy Proposers Win NOAO Time

Sidney Wolff

Four of the six approved SIRTf Legacy proposals have also been awarded time on telescopes at NOAO during the 2001A–2002B semesters, through a collaboration between NOAO and NASA. These proposals are:

- M. Dickinson et al. (STScI); “*Great Observatories Origins Deep Survey*”
- N. Evans et al. (U. Texas at Austin); “*From Molecular Cores to Planets*”
- R. Kennicutt et al. (U. Arizona); “*SINGS: The SIRTf Nearby Galaxies Survey—Physics of the Star-Forming ISM and Galaxy Evolution*”
- C. Lonsdale et al. (Caltech, IPAC); “*The SIRTf Wide-area InfraRed Extragalactic Survey*”

Similar collaborations between NOAO and both STScI and the Chandra X-Ray Observatory have provided investigators the opportunity to request NOAO time as part of their HST Cycle 10 and Chandra Large proposals.

Coudé Spectrograph Available at DAO

David Bohlander and Jim Hesser (DAO)

Former users of the Kitt Peak coudé feed telescope who are trying to cope with the closure of this facility in February 2001, are reminded that the National Research Council of Canada’s Herzberg Institute of Astrophysics welcomes applications for observing time on the 1.2-m McKellar Telescope at the Dominion Astrophysical Observatory (DAO) in Victoria, BC.

The coudé mirror train of the 1.2-m telescope is equipped with high-reflectance coatings to optimize throughput. Three sets of coatings are available: super blue (3500–5300 Å), silver (4500 Å–near IR), and gold (6500 Å–IR). These mirror sets are rapidly interchangeable and self-aligning so that it is possible

to change from one set to another in about two minutes, without the need to re-center on the star being observed.

At the coudé focus, an image slicer ensures high throughput to the coudé spectrograph, where one of two optical paths may be selected. A 32-in focal length spectrograph camera can be combined with one of six available diffraction gratings (of 300, 600, 830 and 1200 l/mm) which have various blaze angles, and some of which are efficient in either first or second orders. These yield many possible reciprocal dispersions, of which 6.5, 10, 18, and 41 Å/mm are the most commonly used. Alternatively, the telescope beam can illuminate a mosaiced 830 groove mm⁻¹ grating

and a 96-in focal length camera to give a spectrum in the red (1st order) at 4.8 Å/mm or in the blue (2nd order) at 2.4 Å/mm.

The corresponding resolution of all these spectrograph configurations ranges from 0.07 to 1.2 Å. Two CCDs with 4096 15-µm pixels along the dispersion direction are available. SITE 4 is a thin, backside-illuminated device suitable for observing at wavelengths less than approximately 7000 Å, while the thick, frontside-illuminated UBC detector is used for longer wavelengths where fringing with the thin device can be problematic. Note that the DAO spectrographs are *not* echelles so that wavelength coverage ranges from

continued

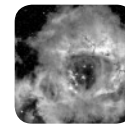

Coudé at DAO continued

a rather modest 140 Å with the long camera and the 830 groove mm⁻¹ grating operating in second order, to approximately 2400 Å with the short camera and 300 groove mm⁻¹ grating. Wavelength calibrations for the spectrographs are provided by Fe-Ar, Cd-Ar, or Th-Ar hollow cathode discharge lamps.

The DAO welcomes long-term, well thought out science programs that have the potential for high impact (basically, what are sometimes thought of as “key projects”). Every attempt is also made to try to

assign time in blocks that recognize the weather factor in the British Columbia climate. Moreover, the availability of contract service observing greatly reduces the risk that busy academics face in travelling to carry out their own observing. Similarly, for thesis work we try to ensure that adequate time is assigned to facilitate completion of programs.

More detailed information about the DAO 1.2-m telescope (as well as contract service observing, and the imaging and spectroscopy capa-

bilities of the 1.8-m Plaskett Telescope) can be found on the Web at <http://www.hia.nrc.ca/facilities/dao/>, and questions can be emailed to DAO_Telescopes@hia.nrc.ca. Both telescopes are scheduled on a quarterly basis, with application deadlines just one month before the start of the quarter. For example, for the April-June 2001 quarter the deadline is 1 March 2001. Observing forms can be submitted by e-mail or via the WWW. See <http://www.hia.nrc.ca/facilities/dao/observing/forms/> for more information.

NOAO Nighttime Proposals Due for 2001B

The NOAO Proposal Team

Proposals for observing time for Semester 2001B (August 2001–January 2002) at the Gemini North and South telescopes, the Cerro Tololo Inter-American Observatory, the Kitt Peak National Observatory, and for community access time at the Hobby-Eberly Telescope and MMT Observatory 6.5-m telescope are due by Saturday evening, 31 March 2001, midnight MST.

Proposal materials and information are available on our Web page (<http://www.noao.edu/noaoprop/>). Investigators should use the Web form to initiate all proposals. Although the Web form is the starting point for all proposals, we do provide both e-mail and Web options for submission.

- **Web submissions.** The Web form may be used to complete and submit proposals. The information provided on the Web form is formatted and submitted as a LaTeX file, including figures that are “attached” to the Web proposal as Encapsulated PostScript files.

- **E-mail submissions.** If you prefer to prepare your proposal locally as a LaTeX file and then submit it by e-mail, that option is still available. Investigators using the Web form are requested to fill out certain information on the general information, investigator information, and run information pages (what is required through the Web form varies with each facility, so read the instructions carefully). After these pages have been completed, a “customized” LaTeX file can be downloaded or returned to you by e-mail for completion and submission by e-mail. Follow the instructions in the LaTeX template for submitting proposals and figures.

The addresses on the next page will help with proposal preparation and submission:



Observational Programs

Nighttime Proposals continued

Web proposal materials and information.	http://www.noao.edu/noaoprop/
Request help for proposal preparation.	noaoprop-help@noao.edu
Address for thesis and visitor instrument letters, as well as consent letters, for use of PI instruments on the MMT.	noaoprop-letter@noao.edu
Address for submitting LaTeX proposals by e-mail.	noaoprop-submit@noao.edu
Gemini related questions relating to operations or instrumentation.	usgemini@noao.edu and http://www.noao.edu/gateway/gemini/support.html
CTIO-specific questions related to an observing run.	ctio@noao.edu
KPNO-specific questions related to an observing run.	kpno@noao.edu
HET-specific questions related to an observing run.	het@noao.edu
MMT-specific questions related to an observing run.	mmt@noao.edu

The tables on the following pages summarize instruments available (or expected to be available) in the 2001B semester at the Gemini North and South Telescopes, the Cerro Tololo Inter-American Observatory, the Kitt Peak National Observatory, the Hobby-Eberly Telescope, and the MMT Observatory 6.5-m Telescope. For further information about the capabilities and performance of these instruments, and links to instrument manuals, check the NOAO Facilities Web page <http://www.noao.edu/gateway/facilities.html>.

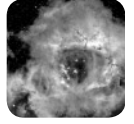

CTIO Instruments Available

Spectroscopy		Detector	Resolution	Slit
4-m	Hydra + Fiber Spectrograph	SIte 2K CCD, 3300-11,000Å or Loral 3K CCD, 3300-11,000Å	300-2000	Fiber 120+fibers, 2 arcsec aperture
	R-C CCD Spectrograph Echelle Spectrograph + Blue Air Schmidt Echelle Spectrograph + Long Cameras OSIRIS IR Imager/Spectrometer	Loral 3K CCD, 3100-11,000Å Loral 3K CCD, 3100-11,000Å SIte 2K CCD, 3100-11,000Å HgCdTe (1024 ² , 1.0-2.4µm)	300-5000 15,000 98,000 1200 or 2900	5.5' 5.2' 5.2' 1.2'
1.5-m	Cass Spectrograph OSIRIS IR Imager/Spectrometer	Loral 1200x800 CCD, 3100-11,000Å HgCdTe (1024 ² , 1.0-2.4µm)	<1300 1200 or 2900	7.7' 4'
	Imaging			
4-m	Mosaic II Imager OSIRIS IR Imager/Spectrometer	8Kx8K CCD Mosaic HgCdTe (1024 ² , 1.0-2.4µm)	0.27 0.15 or 0.4	36' 1.2' or 3'
	1.5-m	Cass Direct Imaging ASCAP Optical Photometer OSIRIS IR Imager/Spectrometer	SIte 1K/2K CCD HgCdTe (1024 ² , 1.0-2.4µm)	0.44/0.24 0.4 or 1.1
0.9-m		Cass Direct Imaging	SIte 2K CCD	0.40 13.6'
YALO	ANDICAM Optical/IR Camera	Loral 2K CCD HgCdTe 1K IR	0.3 0.2	10' 3.3'

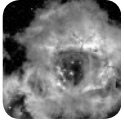

HET Instruments Available

Detector	Resolution	Slit	Multi-object
Marcario Low-Res Spect.	600 1300	1.0"-10"x4' 1.0"-10"x4'	13 slitlets, 15" x 1.3" in 4' x 3' field
High Resolution Spectrograph	30,000-120,000	2" or 3" fiber	single

Gemini Instruments Possibly Available

GEMINI NORTH	Detector	Spectral Range	Scale ("/pixel)	Field
NIRI (queue & classical)	1024x1024 Aladdin Array	1-5 μ m	0.022, 0.050, 0.116	22.5", 51", 119"
G-MOS (queue only, after 11/1)	3 - 2048 x 4068 CCDs	0.36-1.1 μ m	0.072	5.5' multislit & imaging
Hokup'a AO Camera (classical only)	QUIRC 1024x1024 HgCdTe	1-2.5 μ m	0.020	20"
OSCIR (classical only)	128x128 Si:As IBC	8-25 μ m	0.084	11"

GEMINI SOUTH	Detector	Spectral Range	Scale ("/pixel)	Field
OSCIR	128x128 Si:As IBC	8-25 μ m	0.084"	11"
FLAMINGOS I (classical only, until 11/30)	HgCdTe 2048 x 2048	0.9-2.5 μ m	0.075"	2.5' x 2.5' (imager)
Acquisition Camera (Queue, TOO)	1K x 1K frame-transfer CCD	UBVRI	0.12"	2' x 2'
Phoenix (classical only)	512 x 1024 InSb	1-5 μ m	0.1"	R = 70,000

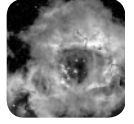

KPNO Instruments Available

Spectroscopy		Detector	Resolution	Slit	Multi-object
Mayall 4-m	R-C CCD Spectrograph	T2KB CCD	300-5000	5.4'	single/multi
	CCD Echelle Spectrograph	T2KB CCD	18000-65000	2.0'	
	IR Cryogenic Spectrograph	InSb (256x256, 0.9-5.5µm)	300-1500	0.8'	
	FLAMINGOS (3)	HgCdTe (2048x2048, 0.9-2.5µm)	1000-3000	10'	single/multi
WYVN 3.5-m	Hydra + Bench Spectrograph	T2KC CCD	700-22000	NA	~100 fibers
	DensePak (1)	T2KC CCD	700-22000	IFU	~90 fibers
2.1-m	GoldCam CCD Spectrograph	F3KA CCD	300-4500	5.2'	
	FLAMINGOS (3)	HgCdTe (2048x2048, 0.9-2.5µm)	1000-3000	20'	single/multi

Imaging		Detector	Spectral Range	Scale ("pixel)	Field
Mayall 4-m	CCD Mosaic	8Kx8K	3500-9700Å	0.26	35.4'
	SQIID	InSb (4 512x512, 0.9-3.3µm)	JHK + L (NB)	0.39	3.3' circular
	FLAMINGOS (3)	HgCdTe (2048x2048, 0.9-2.5µm)	JHK	0.3	10'
	Prime Focus CCD Camera (2)	T2KB CCD	3300-9700Å	0.42	14.2'
	IR Imager (2)	HgCdTe (256x256, 1-2.5µm)	JHK + NB	0.60	2.5'
	Mini-Mosaic	4Kx4K CCD	3300-9700Å	0.14	9.3'
WYVN 3.5-m	CCD Imager	T2KA CCD	3300-9700Å	0.305	10.4'
	IR Imager (2)	HgCdTe (256x256, 1-2.5µm)	JHK + NB	1.1	4.7'
	SQIID	InSb (4 512x512, 0.9-3.3µm)	JHK +L(NB)	0.68	5.8' circular
	FLAMINGOS (3)	HgCdTe (2048x2048, 0.9-2.5µm)	JHK	0.6	20'
WYVN 0.9-m	CCD Mosaic (4)	8Kx8K	3500-9700 Å	0.43	59'

(1) Integrated Field Unit: 30" x 45" field, 3" fibers, 4" fiber spacing.
 (2) Limited to narrow-band filter work and scheduling backup.
 (3) Available December-January only.
 (4) Shared risk.

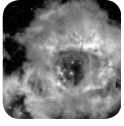

Observational Programs

MMT Instruments Available

Spectroscopy	Detector	Spectral Range	Scale ("/pixel)	Field
Spectrograph	Blue Channel	0.32-0.8 μ m	0.3	150"
	Red Channel	0.5-1.0 μ m	0.3	150"
MIRAC3	128 x 128 Si:As BIB array	2-25 μ m	0.14, 0.28	18.2, 36"
MiniCam	2 – EEV 2048 x 4608 CCDs	UBVRI	0.05	3.7'
FSPEC (Near-IR Spectrometer)	HgCdTe array	JHK	1.2	Resolving Power \leq 3500



CTIO OPERATIONS

Site Survey for the GSMT

Robert Blum, CTIO

The Giant Segmented-Mirror Telescope (GSMT) is a top priority for the coming decade in optical/infrared (O/IR) ground-based astronomy (as recommended by the McKee–Taylor Decadal Review: *Astronomy and Astrophysics in the New Millennium*). Science objectives and technology development will emerge in the next few years as this 30- to 100-m ground-based telescope project takes shape.

Perhaps more than ever, the detailed selection of a site for the GSMT will be key to the success of its operation. For example, how important will minimizing wind loading on the massive structure be compared to optimizing atmospheric seeing? The former may be one of the key site parameters for the next generation of very large telescopes, while the latter has been the defining characteristic of current 10-m class observatory sites. As conceptual designs for the GSMT become available, compatible site characteristics will be determined and the ideal site defined. The timescale to find such a site is not necessarily short, so the site testing capability and

rationale must be developed in parallel with the telescope concepts.

In order to successfully find the best GSMT site, AURA has established a site survey working group as part of the GSMT conceptual design work being carried out by its New Initiatives Office (NIO). The site survey group is headed by Alistair Walker (CTIO). It draws on expertise from various AURA organizations (e.g., NOAO/CTIO and Gemini), as well as outside sources. The group has already begun collaborating with the European Southern Observatory

(ESO), the University of Tokyo, and private US observatories to share information on site survey strategies, technology, and results.

Site selection for the GSMT is currently focusing on northern Chile (detailed characterization of Mauna Kea is also planned to support operations of existing telescopes there). The site survey group is working to determine which properties best characterize a site for the GSMT, given the GSMT's own technological needs and scientific goals. The broader plan is to outline how a large-scale survey can be systematically undertaken to arrive at the best site and then to actually execute the survey. A working outline of the site selection process can be found on the site survey group Web page (<http://www.ctio.noao.edu/sitetests/>).

The first stage of execution of the overall plan is underway, as witnessed by the site group's trip to the Atacama desert in northern Chile in October 2000. The trip was an opportunity to experiment with two pieces of new site testing equipment—a weather tower



Atmospheric seeing measurements are being made in the Atacama desert of Chile to characterize sites for the Giant Segmented-Mirror Telescope. A robotically controlled differential image motion monitor (DIMM) was used on the 5400-m (17,500 ft) summit of Cerros de Honar. (Photo: Brooke Gregory)

continued

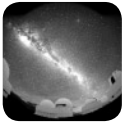

Site Survey continued

and a differential image motion monitor (DIMM). The final survey will certainly make use of these two instruments for detailed measurements and characterization. The site survey group is thus gaining experience now, and developing reliable technology for the time when the full survey will be conducted.

In making the trip, the site survey group called on our friends at Cornell University (in particular, Riccardo Giovanelli) who are actively characterizing sites on the Chilean national science preserve, known as Chajnantor, for the mid-infrared Large Atacama Telescope (<http://astrosun.tn.cornell.edu/atacama/atacama.html>). This area of the high Atacama desert, located roughly 30 km east of San Pedro de Atacama in the Chilean Andes, is also the site for the Atacama Large Millimeter Array

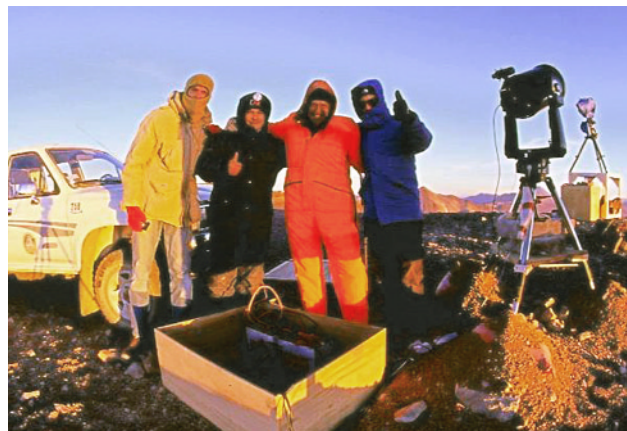

The CTIO site survey team celebrates their successful work in the challenging conditions of the high Atacama desert. Left to right: Maxine Boccas, Edison Bustos, Brooke Gregory, and Bob Blum. (Photo: Maxine Boccas)

(ALMA), a joint venture between the National Radio Astronomy Observatory (NRAO) and ESO (<http://www.mma.nrao.edu>). The site survey group set up a DIMM and a weather tower on the 5400-m summit of the Cerros de Honar ridge near the ALMA site, with the dual goals of operating its first remote DIMM and leaving a remote weather station behind to record basic meteorological data for a minimum three-month period.

The trip was a smashing success for the site survey group. The DIMM, which is described in detail at <http://www.ctio.noao.edu/telescopes/dimm/dimm.html>, is based upon an ESO design by M. Sarazin and F. Roddier (1990, *A&A* 227, 294). The DIMM was operated on parts of four nights, including two nights in which it was left in robotic mode happily making seeing measurements (including acquisition and guiding) on a pre-selected list of targets while the team was sleeping in San Pedro. The robotic mode is particularly important in remote locations like

Chajnantor, which tax the human observers to the limit. The weather tower was left logging data from eight sensors (three temperature, pressure, humidity, wind speed, wind direction, and solar radiation). A quick check-up trip on December 23 found the tower to be in excellent shape, despite the harsh Atacama conditions, and taking data on all sensors. A preliminary look at the data downloaded from the tower in December shows wind speeds in excess of 100 km/h. These gusts were recorded on Cerros de Honar and do not necessarily reflect conditions on the ALMA site itself or typical nighttime conditions.

The working conditions on Honar are difficult, owing to the high altitude of 5400 m (17,500 ft). A typical day/night (not including the final nights when the DIMM was operated robotically) consists of four to six hours on site, with three to four hours in transit to and from San Pedro. No member of the site survey group team or the Cornell group had serious altitude problems, but

continued



A weather tower was set up over Cerros de Honar to log data over an extended period. Edison Bustos and Brooke Gregory are seen finishing the cabling in late October 2000. (Photo: Bob Blum)

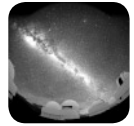

Site Survey continued

the adverse effects on the body limit what can be accomplished in one day. This is particularly true of the first several days at altitude when the most strenuous setup activity occurs and the body is least acclimatized. A set of safety guidelines is being developed with input from NRAO, Cornell, and ESO scientists working on-site. Little convincing of the need for basic safety is needed once one arrives on Chajnantor. Still, strenuous or not, the work has its own rewards, as anyone who has been to the Atacama can attest.



The site survey group team is indebted to the many CTIO staff whose help with developing the weather tower and DIMM was invaluable. The team is also grateful for the help of Riccardo Giovanelli and his Cornell group (Chuck Henderson and Luke Keller) in preparing for and executing these first characterization measurements.

The sun sets as night work begins for the site survey team. Atmospheric seeing was recorded on four nights in late October, including two nights of robotic operation. A robotic mode is critical in locations like the high Atacama desert where human observers are taxed to the limit by the altitude (17,500).

Light Pollution Control in Chile

Hugo E. Schwarz

It has been realized for many years that good, dark astronomical sites are rare, and therefore precious. In recent years it has also become clear that finding and testing sites is not enough; once you have a good site identified and characterized, you must also protect it, especially from light pollution. Light pollution is an increasing threat to ground-based optical and IR astronomy.

We view the work on light pollution prevention that has been going on at CTIO over the last seven years or so as an integral part of site work, which itself consists of:

- Searching and surveying for new sites for future projects (see “Site Survey Project for the GSMT” in the current newsletter),

- Characterization and comparison of sites, and
- Protection of these existing and potential sites. In total, nine CTIO staff members are involved in all aspects of this work, spending varying fractions of their time on it. Here I will limit myself to the site protection aspect.

Four CTIO employees are involved part-time in site protection (http://www.ctio.noao.edu/light_pollution/english_index.html), as well as various staff members in Chile at ESO and Las Campanas. For example, the CTIO Director, Malcolm Smith, has recently been elected Vice President of IAU Commission #50 “Protecting Existing and Potential Observatory Sites”

continued

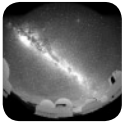

Light Pollution continued

(<http://www.jb.man.ac.uk/iaucom50/>), Chairman of its Working Group on “Controlling Light Pollution” (http://www.ctio.noao.edu/light_pollution/iau50/), as well as being made a board member of the International Dark Sky Association (IDA), which is headquartered in Tucson. In addition, there are now two full-time employees at the recently created OPCC—Oficina para la Protección de la Calidad de los Cielos del Norte de Chile, or Office for the Protection of the Quality of the Skies in the North of Chile. Information on OPCC can be found at <http://www.opcc.cl>. Most of this Web site is in Spanish, at present.

The local work, which started in late 1993, culminated five years later in a new national-level guideline being signed by the President of Chile. This guideline, with the effect of law, defines the technical aspects required of outdoor lighting fixtures of all types in the Second, Third, and Fourth regions of Chile, i.e., all the regions that host major international observatories. CONAMA, the Chilean equivalent of the US Environmental Protection Agency, has the task of enforcing the new regulations.

Links between the various observatories in Chile have been forged, and the light pollution work now has a working budget provided by all the international optical observatories and supplemented by annual contributions from CONAMA. An excellent collaboration has also been set up between CTIO and the Catholic University of Valparaíso. The university’s photometric laboratory, led by Professor Enrique Piraino, consults on technical issues regarding the modification or exchange of outdoor lighting fixtures to reduce both upward directed light flux and the spectral bandwidth of the light. In many cases, the running costs of the light installations can also be reduced, making this an attractive proposition for town councils.

Much groundwork has also been done in the field of public education and awareness related to control of light pollution. A traveling planetarium, donated by Gemini, administered by AURA, and operated by CTIO in conjunction with the newly-formed local RedLaSer schools network (<http://www.ctio.noao.edu/AURA/redlaser/>), has seen much use, especially by school children (see <http://www.ctio.noao.edu/AURA/planetario/>). CTIO donated the telescope, dome, and CCD camera used by the public observatory called Mamalluca (see:

<http://www.angelfire.com/wy/obsermamalluca/principal.html> and the article by Joshua Winn, “Exploring the Sky at Mamalluca,” in the February 2001 issue of *Sky & Telescope* magazine). This municipal observatory has been very successful in attracting astronomical tourism to the town of Vicuña in the Valle de Elqui (Elqui Valley). Indeed, the tourist office in La Serena has published a booklet in English and Spanish for astro-tourism in the Valle de Elqui. The town council of Vicuña has been most collaborative in this effort, changing several hundred street lighting fixtures. This lighting modification has resulted in a reduction of upward flux by a factor of 25 and a lowering, by a factor of 2, of the running costs, while increasing the amount of light on the streets. The reduction of upward flux directly impacts Cerro Tololo positively, as this is the closest sizeable population center.

Other recent successes of the light pollution control effort in Chile include substantially reducing stray light from the “Cruz del Tercer Milenio” in Coquimbo, which is on a direct line of sight to Gemini South; adapting large floodlights at a new shopping mall in La Serena; improving outdoor lighting at the University of La Serena; securing a statement of intent from the mayor of La Serena regarding the improvement of the bright lights along the beachfront, a somewhat delicate issue in the region; and collaborating with an Andacollo mine, which has a line of sight to Tololo, on the placement of floodlights used for nighttime work.

Much more information about these issues can be found on the following Web site: http://www.ctio.noao.edu/light_pollution/iau50/. Under “Images” is a self-guided presentation on light pollution issues with many pictures. Click on the “A” button to get comments on any selected image. These comments will be updated over time. Click on the “i” button to get an index of slide titles. NOAO Public Affairs and Educational Outreach and the International Dark-sky Association are working to develop an improved version of this approach to document local advances in controlling light pollution.

A couple of related sites are: http://www.ctio.noao.edu/site/pachon_sky/, an analysis of the sky quality above Cerro Pachón, the Gemini and SOAR site; and <http://www.darksky.org/idal/index.html>, the International Dark-sky Association site, which is full of useful information.

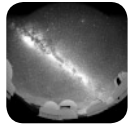

SOAR Update

Steve Heathcote

While the SOAR telescope structure and facility are nearing completion, the SOAR partners are working to build SOAR's initial instrument suite—an optical imager being built at CTIO, the Goodman high-throughput optical spectrograph (North Carolina, Chapel Hill), an IFU-fed bench spectrograph (São Paulo), and the Spartan IR imager (Michigan State). With the first generation instruments underway, the SOAR SAC is beginning to plan for the next and would appreciate input from the NOAO user community. Hence, you are invited to review the information on the current and suggestions for future instruments at http://www.ctio.noao.edu/soar/soar_instruments.html. Please send us your comments!



Under the cover of the circus tent-like temporary roof, installation of the facility electrical equipment is almost complete. Over the next few months, several members of the SOAR project team will move to Chile to participate in the process of onsite integration that will culminate with first light in June 2002.



The SOAR telescope mount is taking shape at the VertexRSI plant in Texas as the major components are completed and assembled, ready for system-level testing prior to being shipped to Chile.

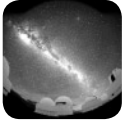

CTIO Telescope and Instruments Available for Semester 2001B

Alistair Walker

Prospective users of CTIO facilities in Semester 2001B are reminded that the Schmidt Telescope will be available only for Michigan programs. Patrick Seitzer (seitzer@astro.lsa.umich.edu) is the Michigan contact scientist.

The CTIO Infrared Spectrograph (IRS) and the small-format infrared imager (CIRIM) are no longer available; OSIRIS is the only IR instrument offered at the 4-m and 1.5-m. The dual IR-optical imager ANDICAM remains available on the YALO 1.0-m telescope. We are

making good progress on building our 2K × 2K IR Imager ISPI, and plan to commission it late in 2001, with visitor use beginning in 2002. Full details are given on the Web at http://www.ctio.noao.edu/ir_instruments/ispi/.

The single-channel photoelectric photometer ASCAP will be not be offered at the 1.5-m after 2001B. Operations at the 1.5-m are being scaled back to make resources available for running SOAR, which is scheduled for first light in June 2002.

The 4-m Echelle spectrograph is also due to be retired at the end of 2001B. However, whether this is a hard or soft retirement depends on the success of the IFU feed to the Hydra bench Spectrograph; tests of this instrument are due to take place in February. Watch our WWW pages for updates; in particular, http://www.ctio.noao.edu/telescopes/TheFuture/crystal_ball.html.

Mosaic II now with 16 Channels

*Knut Olsen, Chris Smith, and Buell Jannuzi
on behalf of the NOAO Mosaic Team*

Starting with the 2001A semester, 16 channel readout mode (i.e., two amplifiers per CCD) with the Mosaic II camera will be available. The new mode will be expected to be the default mode of operation. The change means that the shortest possible cycle time between images, such as that between successive zero frames, will drop from 160 seconds to 100 seconds. Whereas before the overhead on a 10-minute exposure was 25%, it will now be only 15%, which is a

substantial improvement. Observers may no longer find themselves so hard pressed to get enough twilight sky frames.

Some changes are involved with the move to 16 channels. The MSCRED reduction package and MSCDB calibrations database have been updated to handle both 8 and 16 image extensions seamlessly. Users may download both packages from <ftp://iraf.noao.edu/iraf/extern/>. One of the most important changes

in MSCRED is the way in which the crosstalk is calculated and corrected; with two amplifiers reading each CCD, every amplifier produces crosstalk in three extensions rather than one. Also, a step has been added so as to merge extensions read from the same CCD into a single extension at the end of the reduction pipeline, resulting in reduced images that look almost identical to 8 channel readout Mosaic images.

continued

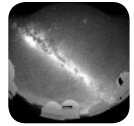

Mosaic II continued

The new MSCDB contains the necessary calibration files for 16 channel readout, including bad pixel masks and astrometric solutions of the correct format, and the multi-victim crosstalk data file. The files used for 8 channel readout mode have also been updated, so users desiring the latest measurements should download the new MSCDB. Indeed, IRAF/ MSCRED may surprise you with an error message during your reductions of newer data sets unless you acquire the latest MSCDB.

In order to more easily provide you with the correct calibration files, the NOAO Mosaic team is working to provide a single Web-based repository for the files for both Mosaic cameras. The Mosaic Web page (<http://www.noao.edu/noao/mosaic/>) contains an archive of crosstalk files, bad pixel masks, and astrometric solutions that we have produced, including notes about each file. Users of both Mosaics may also like to know that filter names have

been given a standard convention at both sites, as well as added descriptive information within the names.

For those who do not desire to read out each CCD with two amplifiers, 8 channel readout is still readily available. Make your desire known when you fill out your visitor support questionnaire (http://www.ctio.noao.edu/obsaid/obsaid.html/supportforms/visitor_support.html) or ask Observer Support.

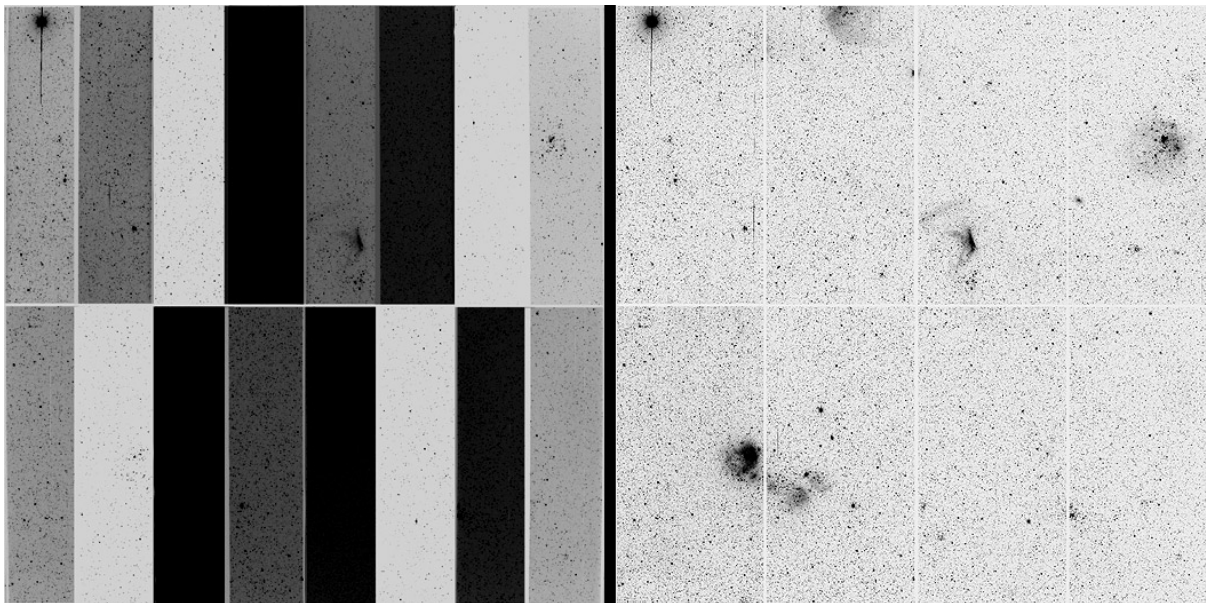

The northeast quadrant of the supershell LMC-4 in the Large Magellanic Cloud, showing a number of OB associations and star clusters. Taken under conditions of 0.75" seeing with the Mosaic 2 camera in 16 channel mode on the CTIO 4-m Blanco telescope, this 20-second V image contains more than 200,000 point sources at the level of 5σ above the background. On the left is the raw image; the image on the right has been processed to remove instrumental artifacts. The seams in the middle of the CCD's visible in the raw image completely disappear in the full reduction process, as do flat-fielding and bias artifacts.

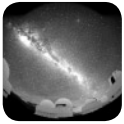

Tom Ingerson Leaves CTIO

Malcolm Smith

Tom Ingerson, CTIO Senior Support Scientist, is heading north in March 2001 to Boulder, Colorado, to pursue as many of his wide range of interests as time permits. Tom has been at CTIO for almost 18 years. During that time, he has alternated with Brooke Gregory as head of Engineering and Technical Services at CTIO and has had tremendous impact on the observatory's development and implementation of new instrumentation, on operations on the mountain and in La Serena, and on the quality of resident life in the La Serena *recinto*.

It will not be possible to fill the unique role that Tom has shaped for himself with any single individual. His wide intellect and outstanding human qualities will be missed. Fortunately, he will continue a virtual presence at CTIO, continuing to manage (primarily via the Internet) as a consultant the Instrument Selector/Calibration/Guide System project for SOAR.

Tom is a man of amazingly varied abilities and interests. After graduating from the University of California at Berkeley with an A.B. in physics and a short stint as a junior engineer at White Sands Missile Range, he obtained his Ph.D from the University of Colorado with a dissertation in the field of General Relativity. From there he moved to New Mexico and then to Idaho, where he rose to a full professor in physics at the University of Idaho.

Many of us at Tololo first got to know Tom in the mid-70s when he spent a year at the observatory. By then his talents for instrumentation had become obvious to everyone, and in 1983 he was persuaded to return to Chile and stay for a "little while longer."

Throughout his career, Tom has shown a remarkable ability to stay abreast of new developments in technology. His expertise in telecommunications enabled him to design and build a T-1 microwave system between La Serena and Cerro Tololo and negotiate with NASA for the installation of a satellite Internet connection to Cerro Tololo in the late '80s. This was the first such link to be installed in South America. More recently, Tom and Jim Kennedy from the Gemini project obtained NSF funding for a very high speed communications system between La Serena, Cerro Tololo, and Cerro Pachón. Negotiations are now nearly complete for the establishment within the next six months of a fast connection to Internet2 via under-sea fibers.

Tom has applied his ability to produce creative solutions to a considerable range of instrumentation challenges. Examples abound and include the Argus fiber-fed multi-object spectrograph which was used at the prime focus of the Blanco 4-m for many years and the 1.5-m Bench-Mounted Echelle spectrograph (BME). The BME has seen effective

continued

New Rates at the AURA Observatory

Elaine Mac-Auliffe

It has been considered necessary to increase some of the rates charged at the AURA Observatory in Chile in order to maintain the same service and support that has been dispensed to visitors and staff throughout the years. These new charges will come into effect 1 February 2001.

Rooms in the Santiago Guest House will cost US\$50 a night and will include breakfast. For more information on Guest House changes and charges, please see the article on Page 16 of *NOAO Newsletter 64*.

Lodging plus the use of a car on Cerro Tololo will cost US\$45 per day, and US\$35 without use of a car. If you wish to use a car, you will need to bring along your driver's license. The cost for breakfast, lunch, dinner, and night lunch will be US\$15 each. A fare of US\$60 for the round trip on the shuttle (La Serena–Tololo–La Serena) has also been implemented.

Updated information for minor changes in the dollar rate and airport taxes for trips to La Serena can be found at http://www.ctio.noao.edu/diroff/obser_trav.htm.

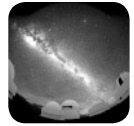

Ingerson Leaves continued

use in a wide variety of programs, most recently providing emission line lists for use in the analysis of the spectra of AGN. Argus has since been replaced by Hydra-CTIO, for which Tom was the project manager and designer of the spectrograph. The effective collaboration between Sam Barden and Tom Ingerson set a reference standard for effective joint work on instrumentation between the groups in Tucson and La Serena. Hydra-CTIO has brought the ability to take 100+ spectra over a wide field with fast fiber deployment to Cerro Tololo. For work requiring higher throughput and resolution, Tom designed an integral field unit to feed the Hydra spectrograph. It is currently in the commissioning phase.

Wearing his optical engineering hat, Tom initiated and managed projects to design and build wide-field, high-resolution corrector optics incorporating Atmospheric Dispersion

Compensation (ADC), first at Prime Focus (the PFADC) and then at the R/C focus (RCADC) of the Blanco-4m, the former being necessary for Argus and the latter for Hydra.

Because of his interest in networking, Tom became an early devotee and proselytizer of the Internet and Linux when almost no one had heard of either one. He has since become a networking and software expert, and as such, he was the natural choice to head the CTIO Computer Applications Group and act as webmaster of CTIO's WWW site.

Life on the *recinto* changed irreversibly in 1985 when Tom designed and built a 7-m dish to pick up satellite television signals directly from the US. The system, built on a shoestring out of scrap steel and wire mesh, surprised many of its skeptics when it worked the first time it was turned on. It functioned

for years, delivering English language television to grateful *recinto* residents until newer technology eliminated the need for it.

After Tom departs, one of his legacies will continue to grow. The "Arboretum Chileno" that he planted in an unused common area behind his house contains many examples of native Chilean trees and plants, and has provided Tom with sharp insight into the structure of the La Serena desert's natural ecosystem. The arboretum has given all *recinto* residents a place to enjoy and see some of the species of plants that were here before Europeans irrevocably modified the environment. He has taught many of us some of the basics of living harmoniously in close proximity to each other. This has been a vital component of the well-known esprit de corps here in La Serena.

How to Contact CTIO

The Web	http://www.noao.edu/ctio
Questions	ctio@noao.edu
E-mail a Staff Member	first initial+last name@noao.edu

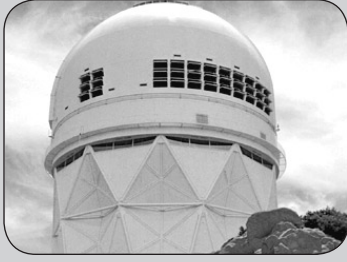

K P N O

Operations

WIYN to Operate the Kitt Peak 0.9-meter Telescope: NOAO Users to Gain Continuing Access to Mosaic

Richard Green

A panel of reviewers met last September to review proposals submitted to operate the Kitt Peak 0.9-m telescope. They found that the proposal submitted by the WIYN Consortium was superior in the opportunities it offered for scientific research and education, as well as in the management of refurbishment and operations. As of this writing, agreements with AURA and NSF are in the approval process. The proposal effort was guided strongly by the university partners in WIYN and additional participants that teamed with the WIY members. Of course, NOAO was not a co-proposer, abstained from the WIYN, Inc., deliberations, and constituted an external review panel to consider the transfer of operations. We were, however, approached by WIYN to make the following arrangement.

A key aspect of the operations plan is that NOAO will loan CCD cameras to WIYN in exchange for observer access. In particular, the Mosaic camera will continue to be scheduled on the 0.9-m when there is a sufficiently long block

of other instrument use on the 4-m. Consistent with the WIYN agreement, NOAO users will receive 40% of the available Mosaic time on the 0.9-m.

The first stage of WIYN operations will be a long-needed refurbishment of the telescope control system. The WIYN 0.9-m partners are targeting a return to operations for this coming summer. NOAO will therefore accept proposals for observing with the Mosaic CCD camera on the 0.9-m during Semester 2001B. The probability of time being available will no doubt be higher toward the end of the semester. There are two potential risks in such proposals. One is that the refurbishment takes much longer than currently anticipated, so that scheduling for scientific use becomes very limited. The other is that we might make Mosaic available prior to full interoperability with the new telescope control system. There may be restrictions on header coordinate information, *mosdither*, or other telescope control from the instrument. Imaging performance with Mosaic is anticipated to be unchanged from previous semesters.

We believe that the new arrangement will be mutually beneficial for KPNO observers and for WIYN and its partners. KPNO observers retain access to the highly demanded 1-degree field of view of Mosaic on the 0.9-m, the telescope receives a critical performance upgrade to a maintainable modern control system, and the over-stretched support staff is relieved of operations responsibility. WIYN and its partners gain access to Mosaic for imaging science and as a match to the WIYN/Hydra field. The remaining time will be scheduled with a 2K x 2K CCD, which provides for synoptic observations, photometric calibrations, and educational opportunity. NOAO use of a 2K-square CCD will begin in Semester 2002A.

Ata Sarajedini (Florida) is the Telescope Scientist leading the refurbishment effort. Bob Mathieu (Wisconsin), Chair of the WIYN Board of Directors, assembled the expanded proposal partnership and led the proposal preparation effort. The successful outcome will be continuing productive use of the unique wide-field combination of the 0.9-m and Mosaic on Kitt Peak.



FLAMINGOS Successful Commissioning

Jay Elias and Richard Green

FLAMINGOS, an IR imager and multi-object spectrometer developed as a user instrument by the University of Florida with collaboration and support from NOAO, had successful commissioning runs on the Kitt Peak 2.1-m and 4-m telescopes in December 2000. The runs enabled us to determine instrument performance in imaging mode and to get positional data to enable testing of the instrument's multi-slit mode early in 2001. They were also valuable for initial science for scheduled projects proposed by astronomers at Florida. FLAMINGOS is scheduled for 60 nights on Kitt Peak in the current semester (2001A), for both imaging and spectroscopic projects.

The faintest sources visible in the first light image of the Orion nebula are at least 17th magnitude. One can compare this image to the 2MASS Orion data (<http://www.ipac.caltech.edu/2mass/gallery/orionatlas.jpg>) to see the greater depth achieved by FLAMINGOS with longer integration time and a larger telescope. The FLAMINGOS image is assembled from eight dithered 30-second exposures, totaling about 4 minutes of exposure time. The composite image was trimmed to have the same dimensions as a single frame, 21'.

FLAMINGOS Imaging Performance

Measured values for imaging performance are given in the table on the next page. Prospective users need to remember that near-infrared background varies by a factor of three or more. For the K and Ks filters, where the background is mainly thermal emission, the background is correlated with temperature and therefore quite seasonal. At J and H the background is primarily OH airglow and levels are unpredictable. A detailed discussion of background variation is provided in the SQUIID manual (<http://www.noao.edu/kpno/squid/squidmanual.html>), which is equally applicable to FLAMINGOS.

The 2.1-m background data were taken at relatively high airmass and warm (for December) temperatures; the 4-m data were taken at zenith and with ambient several degrees colder. The 4-m night was not completely photometric, so the count levels may be revised in the future. The Ks filter was not present in the instrument, but when installed it should provide roughly half the background of K (more like H) and 90% of the signal on a star. The instrument gain is between 4 and 4.5 electrons/ADU.

continued

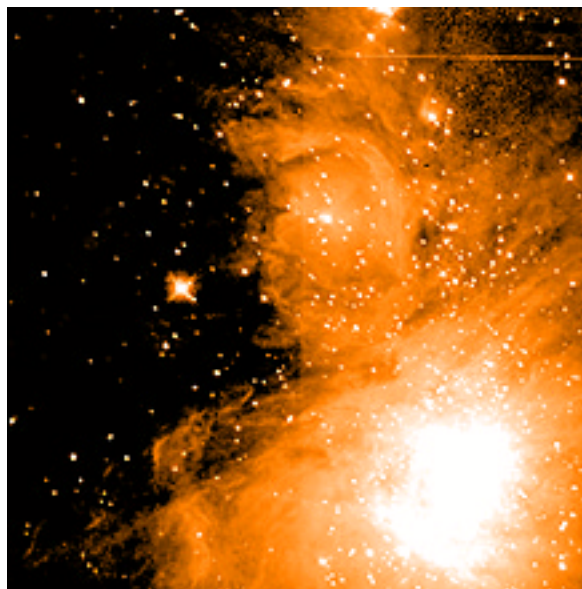

This K-band image of the Orion nebula taken on the 2.1-m telescope represents more than "first light" for FLAMINGOS. In fact, it is the first astronomical picture taken with a 2K x 2K IR array anywhere. The Trapezium is at the center of the bright emission region; the image is saturated there due to the limited gray scale available. The bright region at the extreme top edge of the image is OMC2. The picture measures 21' on a side. North is at the top; east is at the left.



FLAMINGOS continued

Imaging Performance						
Filter	4-m telescope			2.1-m telescope		
	J	H	K	J	H	K
ADU/sec from 10 th mag star	69,000	89,500	87,000	21,000	26,300	26,100
Sky, ADU/pixel/sec	37	241	497	67	563	806
Sky, mag/arcsec ²	15.5	13.8	12.8	15.1	13.1	12.7

The data to accurately determine sensitivity have been obtained only at the 2.1-m, and have not been completely analyzed. Preliminary estimates indicate that one can expect to reach 17th magnitude at K (5 σ) in one minute of integration time; H performance should be a few tenths of a magnitude better; and J performance possibly as much as a magnitude better. These represent data taken in “reasonable” seeing; the large pixels on the 2.1-m mean that sensitivity is not a strong function of seeing. The sensitivity on the 4-m will depend much more on seeing. For good seeing—0.6" FWHM or so—the 4-m sensitivity should scale about as the relative collecting area (1.1 mag). For seeing around 1" FWHM, the 4-m sensitivity gain over the 2.1-m will be around 0.6 mag.

Updated values for typical backgrounds and sensitivities will be available on the NOAO FLAMINGOS Web site by mid-March (<http://www.noao.edu/kpno/manuals/flmn>).

The instrument overhead is quite short—less than 2 seconds to read out the array and write the data to disk—so for most observing programs, the time between images is determined by telescope overheads involved in dithering or rastering. For short offsets, the offset and settling times combined should be around 10 seconds. For short exposures, overhead will significantly reduce efficiency. The engineering array in the instrument has one bad amplifier out of 32. This means that a “slice” of the image 1024 x 128 pixels is missing, and complete coverage of an area requires dithering by at least 128 pixels

total. The delivery date for the science-grade array is an unknown; observers with scheduled time and proposers should assume that they will be using the engineering array.

The detector full-well is large enough that maximum exposure times at K are around 30 seconds (at least in the winter) and a minute or more at J and H. As noted above, the overhead in writing to disk is modest, but for deep observation sequences (many frames at the same location) observers may want to co-add to save disk space.

Predicted Spectroscopic Performance

The spectroscopic performance has not yet been measured; data will be taken (weather permitting) in February. The results of the February run will also be posted in mid-March on the FLAMINGOS Web site (<http://www.noao.edu/kpno/manuals/flmn>).

Based on the imaging performance, the spectroscopic throughput should be roughly half that of CRSP. This implies exposure times will be roughly double—but of course, with several times as much spectral coverage and the ability to observe multiple objects. The assumption is that the FLAMINGOS grism efficiency is roughly comparable to that of the CRSP gratings, which is

continued



FLAMINGOS continued

reasonable but not yet established. It should be noted that FLAMINGOS can image through the slit (or without the slit), which will greatly simplify acquisition.

Availability for 2001B

FLAMINGOS will be in the Southern Hemisphere (Gemini South) starting in late May, and will not return north until the end of October. It will most likely be first scheduled at KPNO starting in early November 2001. FLAMINGOS will then be available for the first part of 2002A, after which it will again go south to Gemini.

The multi-slit mode is *not* supported during the current semester (2001A), but will be supported when FLAMINGOS returns from Gemini South. NOAO will arrange for slit masks to be made for observers. The details of the process are not yet well defined, but should be established well before December. In outline, though, users must plan on the following:

- Masks will be made from user-supplied celestial coordinates (differential α, δ). These will need to be provided to NOAO at least six weeks in advance of the observing run.

- The coordinates will need to be accurate enough to ensure that objects are centered on the slit (a 2-pixel slit is $\sim 0.6''$ on the 4-m, double that on the 2.1-m).
- The slitlet orientation on the 2.1-m will be *fixed*, with the slits running EW (dispersion NS). Rotation of the instrument will be possible on the 4-m, but users should plan on substantial overhead (several minutes) for this process. The default orientation there will also be with slitlets oriented EW. The slit wheel allows for *fine* adjustment of the slit masks, which is enough to correct for rotator and mask installation tolerances.
- The slit mask field is $3' \times 10'$ on the 4-m (roughly double that on the 2.1-m), with the field long axis running along the slits (i.e., EW on the 2.1-m).
- The mask wheel holds 11 masks; cycling the sub-dewar containing the mask wheel takes a good part of the day, so one is limited to 11 MOS fields per night.

Upgrading the Cryogenic Camera

Sam Barden, Arjun Dey, Roger Lynds, Rich Reed, Bill Ditsler, and Charles Harmer

The Cryogenic Camera sprung a leak early last year and was removed from service. As a result, it was decided that, unless it could be significantly improved in performance, Cryocam would be permanently retired. Fortunately, we are very pleased to announce that we did identify areas for significant improvement and have been pursuing the repair and upgrade of Cryocam during the past several months. We present here the enhancements and predicted performance of the

instrument, along with a timeline of when Cryocam might be back in service. These enhancements should equate to an overall efficiency gain of 1.5 over the previous peak performance and a gain of factors of 2 to 10 redward of 8000\AA .

First and foremost, the leak has been found and confidence is high that it can be repaired. Obviously, this was a primary requirement before proceeding with the rest of the

upgrades. We identified the following items to enhance the performance of Cryocam:

- Implementation of a $300\text{-}\mu\text{m}$ thick, high-resistivity, p-channel CCD from Lawrence Berkeley National Laboratory, similar to LB1A described in "Red Hot CCDs at KPNO" in this newsletter. The format is 1980×800 with $15\text{-}\mu\text{m}$ pixels.

continued



Cryogenic Camera continued

- Fabrication of a Volume-Phase Holographic (VPH) grism by Kaiser Optical Systems, Inc. This new VPH grating with 450 lines mm^{-1} will be sandwiched between two prisms for use as a grism. The grating is designed for an undeviated wavelength of 8057\AA , which will also coincide with the peak in the CCD efficiency curve. Resolving power will be about $R = 1000$, roughly 8 \AA resolution, which is nearly a factor of two higher than that achieved with the older set of red grisms. The VPH grism contains an OG550 filter as one of the glass elements, so there will be no need to utilize an additional filter when observing.
- Recoating the Schmidt camera mirror with a high-efficiency, reflective silver coating by Lawrence Livermore National Laboratory. This coating, which is more robust than most available overcoated silver coatings, should be 95% to 98% efficient compared to the measured average efficiency of 90% for the coating that was on the Cryocam mirror.
- A new chip mount that has significantly less obscuration due to the CCD.
- Implementation of a new field flattener lens to fill the larger format of the new CCD. The selection of the new lens was made to improve the wide-field imaging performance of the camera.
- Implementation of a Telescope Nod/Charge Shuffle observing mode (see following article).

continued

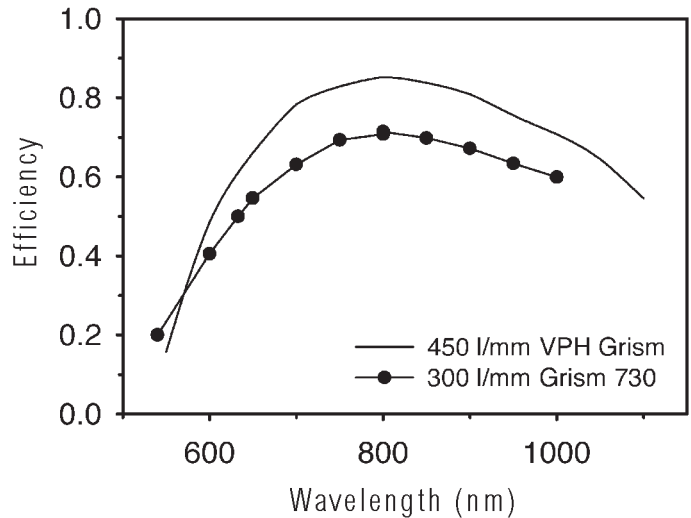

The overall efficiency of the new VPH grism is greater than Grism 730 (300 lines mm^{-1} grating), an original Cryocam grism. Spectral coverage will extend from 5900 through 10400 \AA for all available field angles provided by the instrument.

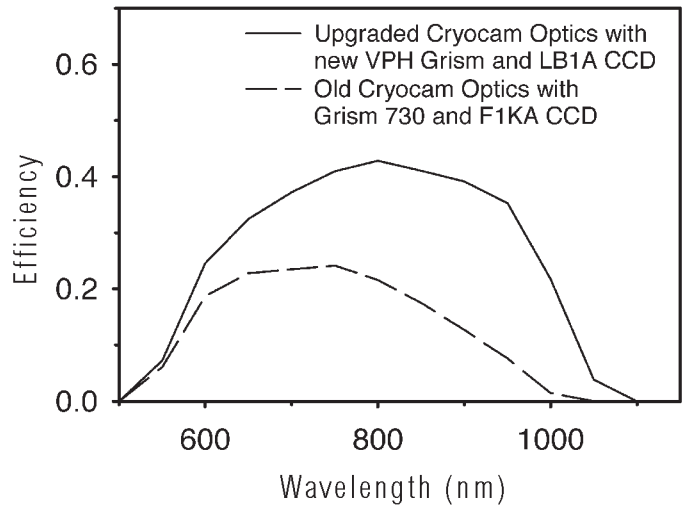

The overall gain in the far red of all of these improvements are nearly equivalent to putting the old Cryocam on an 8-m telescope. The overall expected efficiency for the upgraded Cryocam calculated here includes the telescope, instrument, grism, and detector.



Cryogenic Camera continued

Due to other engineering commitments, the Cryocam upgrade is a low-priority project. Since resources cannot be scheduled in an optimum manner, it is difficult to predict when the project will be finished. Despite this limitation, general public access will likely begin

in the 2002A observing semester. Several milestones will be reached over the next few months. The grating has been fabricated and the prisms are currently under fabrication. The mirror should be returned from LLNL by the time this newsletter is distributed. Testing

and engineering time has currently been assigned at the end of July 2001. If, however, the upgraded instrument is ready prior to 2002A, observers using the RC spectrograph during the 2001B semester may be given the option of switching to Cryocam.

Red Hot CCDs at KPNO

Arjun Dey, Rich Reed, and Roger Lynds (NOAO); Steve Holland and Don Groom (LBNL); and Richard Stover, Mingzhi Wei, and Bill Brown (UCO/Lick)

Through a cooperative program with Lawrence Berkeley National Laboratory (LBNL), KPNO will offer a CCD with peak DQE of nearly 90% at far-red wavelengths. Beginning in 2001B, the new CCD, which will be designated LB1A, will be available in a shared-risk mode for use with the Mayall 4-m RC spectrograph.

LB1A, which has 1980 × 800 pixels, is one of the new 300- μm thick, high-resistivity, p-channel CCDs being manufactured at LBNL. These CCDs have much greater

sensitivity at wavelengths shortward of the Si band gap than any of our existing detectors. At wavelengths beyond 8500 \AA , the gain over T2B is more than a factor of two. The read-out noise and dark current on LB1A are approximately 6 e^- and 70 e^- /hour, respectively. The device does not exhibit any noticeable fringing and is cosmetically clean, with the exception that 58 columns at one end are unusable. We are in the process of obtaining a second CCD that may prove to have better dark current and cosmetics.

continued

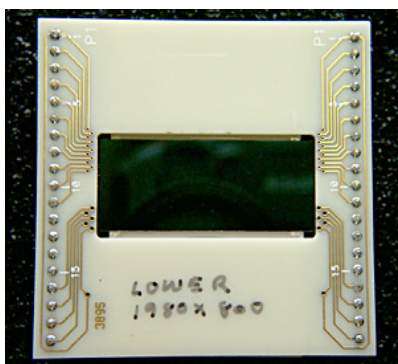

The 198 × 800 LBNL CCD, which will be available for use with the Mayall RC spectrograph, has the highest red sensitivity of any of the CCDs we offer.

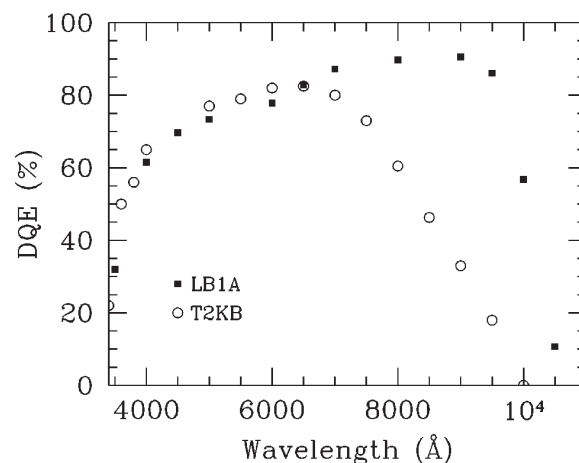

At wavelengths beyond 8500 \AA , the new CCD LB1A shows a twofold gain over T2KB. Both detectors are currently available for use with the RC spectrograph.



Red CCDs continued

Characteristics of LB1A:

Format	1980 × 800
Pixel Size	15 μm
Pixel Scale on RC	0.43"
Read Noise	6 e ⁻
Dark Current	70 e ⁻ /hour

The gain in DQE comes with some cost: the 300-μm thickness of the CCD results in significantly more pixels lost to cosmic ray and background radiation events. Preliminary tests at the KPNO 4-m suggest that there are 1.1–1.7 particle events cm⁻² min⁻¹, and that typically 1–1.5% of the pixels are affected by particle events every hour. As a result, it is best to use multiple exposures per target to help remove the particle events.

The following references have detailed information on these CCDs: S. E. Holland et al. (1996, *IEDM Technical Digest*, 911-914), R. J. Stover et al. (1999, "A 2K × 2K High Resistivity CCD," to appear in *Proc. 4th ESO Workshop on Optical Detectors for Astronomy*, Garching, Germany, 13–16 September 1999); Groom (2000, *SPIE 4008*, 634-645). Additional information can be found on the LBL Web site at <http://ccd.lbl.gov>.

KPNO acknowledges the generosity of the LBNL CCD development team and the Detector Development Laboratory at UCO/Lick Observatory in providing LB1A to KPNO for use by the community on the Mayall 4-m. The CCD development effort was supported by the US Department of Energy (Contract No. DE-AC03-76SF00098), by the National Science Foundation (grant NSF/ATI 9876605), and by the National Aeronautics and Space Administration (grant NRA-99-01-SPA-040).

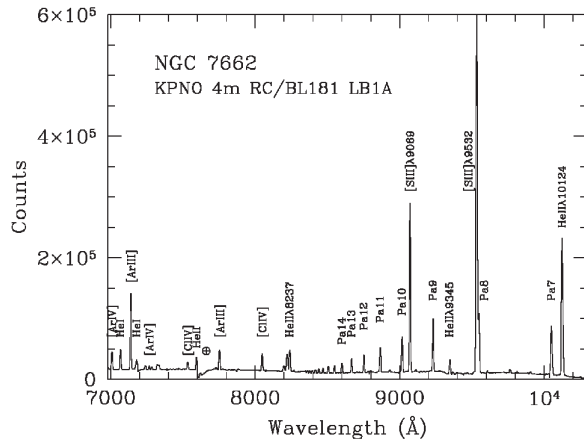

A ten-minute spectrum (through clouds) of the planetary nebula NGC 7662 obtained using LB1A with the RC Spectrograph and the BL181 grating on the KPNO 4-m.



Quick & Dirty CCD Stellar Photometry

Kenneth J. Mighell

Quick & Dirty Photometry (QDPHOT) is a new CCD stellar photometry IRAF task to produce quality photometric reduction of two CCD images of a star field in a very short time. QDPHOT is designed to be a data mining tool for finding high-quality stellar observations in the data archives of the proposed National Virtual Observatory. For example, QDPHOT takes just a few seconds to analyze two Hubble Space Telescope WFPC2 frames containing thousands of stars in Local Group star clusters. QDPHOT is also suitable

for real-time data-quality analysis of ground-based CCD observations, where on-the-fly instrumental color-magnitude diagrams can be produced at the telescope between CCD read-outs.

Information for the MXTOOLS package, including QDPHOT, is given at the MXTOOLS Web site (<http://www.noao.edu/staff/mighell/mxtools>). Once the parent MXTOOLS package has been installed, a short QDPHOT demonstration can be seen by typing 'demoqdpHOT' (don't forget first to open an image

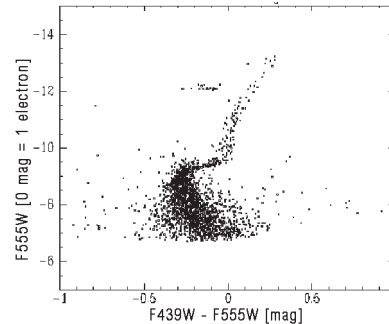

The instrumental color-magnitude diagram of NGC 362 calculated by the QDPHOT demonstration task.

display tool, e.g., '!ximtool &' and then to load the MXTOOLS package by typing 'mxtools' at the *cl* prompt).

This demonstration analyzes two HST WFPC2 observations of the Galactic globular cluster NGC363. On both of the two HST images, 2267 stars are found with a signal-to-noise ratio of eight or greater. Many more stars can be photometered in this field simply by reducing the minimum acceptable signal-to-noise ratio. Finding additional faint stars comes at the cost of increasing the computation time.

New options for QDPHOT are being planned for future releases. An article describing QDPHOT in detail is currently being written and will be posted to the QDPHOT Web page when it is submitted for publication. Suggestions for improving QDPHOT should be sent to mighell@noao.edu.

This research is supported by a grant from the National Aeronautics and Space Administration (NASA), Order No. S-67046-F, which was awarded by the Long-Term Space Astrophysics Program (NRA 95-OSS-16).

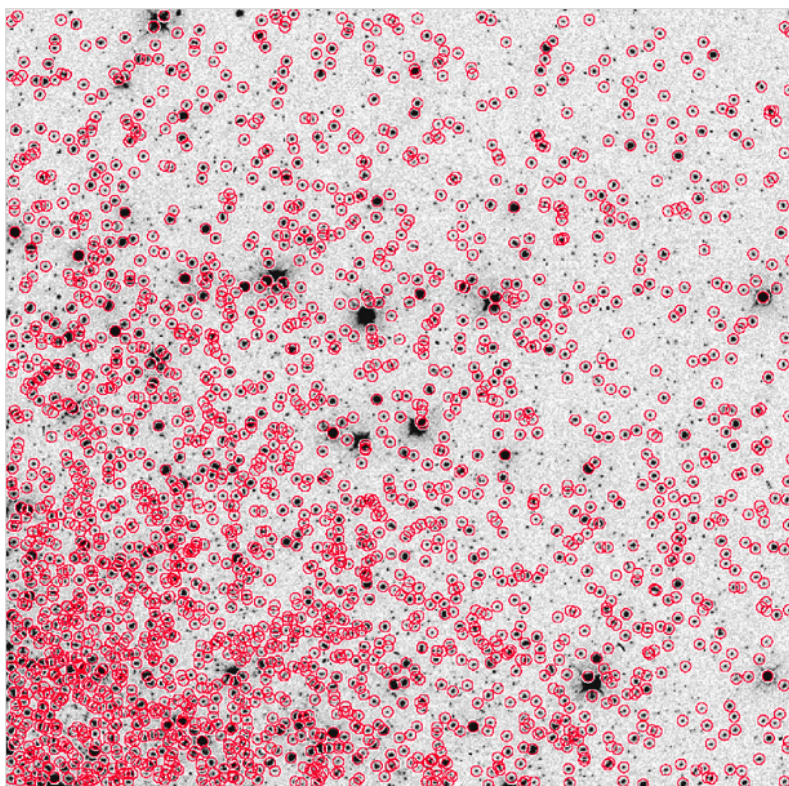

QDPHOT found the circled stars on the HST F555W-filter observation of the globular star cluster NGC 362 in just a few seconds (1 to 5 seconds, generally, depending on the speed and configuration of your computer). Selection criteria can be set within QDPHOT to photometer the uncircled stars, which are generally fainter.



Did You Ever Feed the Coudé?

Caty Pilachowski

The Kitt Peak Coudé-Feed Telescope saw “first light” in the fall of 1973. Prior to the feed’s opening, the coudé spectrograph was used with the Kitt Peak 84-in telescope, but was only scheduled about a third of the nights. An auxiliary feed was constructed to allow more frequent usage of this high-dispersion spectrograph. The scientific productivity of the KPNO coudé spectrograph paid dividends over and over again for this modest initial investment and the small, incremental improvements that followed.

The design of the new telescope was described in a 1971 KPNO Quarterly Report. Helmut Abt was the first observer on 12/13 September 1973, when he took two plates of the star HR 7306 to establish the proper exposure times in comparison to the coudé focus of the 84-in telescope. He then turned the feed telescope over to Thomas Margrave for further observing. Saul Adelman followed a few nights later to observe ι Peg and δ Cas.

Over the years, many refinements have been added to the coudé-feed

generation of digital detectors. This folded two-mirror camera with an aspheric corrector provided both adequate back focal distance and good image quality over a 9-cm detector field. Camera 5 quickly became the most popular of the coudé cameras. When CCDs arrived at the coudé in the early 1980s, Camera 5 was ready and waiting. A few coudé observers may remember with some discomfort our first painful experiences with CCDs, but the detectors soon matured to produce spectra of outstanding signal-to-noise ratio and linearity.

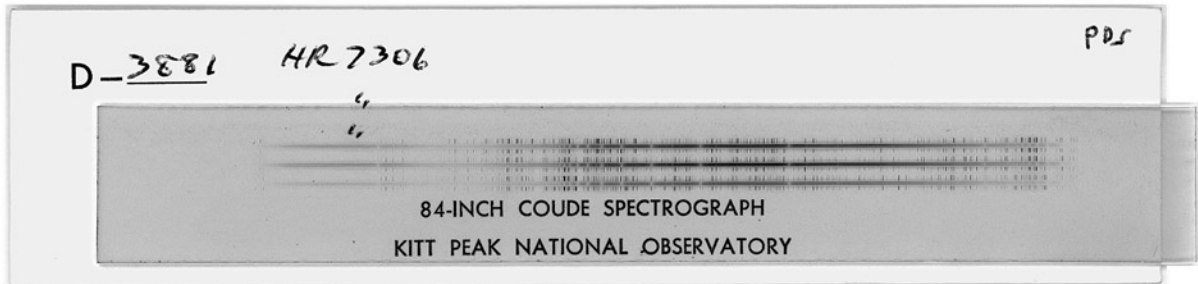

Helmut Abt took test exposures of HR 7306 in September 1973 to establish the relative efficiency of the newly completed coudé-feed telescope relative to the 84-in. The unique combination of a dedicated telescope and a high-dispersion spectrograph, particularly in its echelle/grism mode, yielded many scientific papers on stars, stellar physics, and the interstellar medium over the next nearly three decades of productive use.

telescope and coudé spectrograph. Observers no doubt appreciated the slit-viewing TV and the auto-guider, and—after photographic observing was phased out—conversion of the adjacent darkroom into a modern control room.

A new spectrograph camera (no. 5) was added in 1976, under the leadership of Judy Cohen, from an optical design by Jorge Simmons, to accommodate image tubes and following

Additions to the coudé spectrograph’s stable of gratings further enhanced the telescope’s performance. The arrival of the large “A” grating from (by then) Milton-Roy allowed wider slits and higher dispersions, and a new echelle grating ruled by NOAO staff on the Harrison “C” engine in Tucson provided high spectral resolution. When Jorge Simmons and Daryl Willmarth realized the potential of the 4-m Cryogenic Camera

continued



Feed the Coudé continued

grisms to provide cross-dispersion for the echelle grating, we had available not only high resolution, but excellent spectral coverage as well. This was soon enhanced by the arrival of the Ford 1K x 3K CCD chip.

Early observers may remember the original PDP and paper-tape based control system at the feed telescope, and how much the new control systems, added under the leadership of Richard Wolff and Kim Gillies, improved observing efficiency. The most recent control system, installed in the early 1990s, made the feed the easiest and most efficient telescope to operate on Kitt Peak. And the most reliable, too.

The first journal paper based on data from the feed appears to have been the work of W. R. Beardsley and

M. W. King in the publications of the Astronomical Society of the Pacific in 1976, on the binary κ Peg. Robin Clegg obtained the first Ph.D. based on coudé-feed data for his work on carbon and nitrogen abundances in F- and G-type stars. Other, more recent theses based on coudé feed data include those of Hector Castaneda, James Grigsby, Margaret Chester, Scott Horner, Lewis Jones, Anthony Kaye, and Debra Burris, among others.

In the last five years, more than 100 papers have been published based on coudé-feed data, more than 50% of them in the *Astrophysical Journal* and *Astronomical Journal*. The most prolific recent authors are Frank Fekel, Saul Adelman, Klaus Strassmeier, Claude Lacy, and Helmut Abt.

The list of “first authors” in the last five years includes nearly 60 astronomers.

The coudé feed has made many important contributions to the study of stars and stellar physics over nearly three decades of productive work. The feed has excelled both in synoptic studies of variable stars and binaries, and in spectroscopic surveys. In recent years, the feed has made possible groundbreaking work on the interstellar medium from its high throughput, high-resolution echelle/grism mode.

The last scheduled observer at the Coudé feed was Dave Soderblom, on 31 January 2001. He repeated Abt’s first exposure with a new CCD spectrum of HR 7306.

Optical Spectroscopy Learns the Nod-and-Shuffle

Arjun Dey, Roger Lynds, Rich Reed, Rob Seaman, Nigel Sharp, Jim DeVeney, Bob Marshall, Dave Mills, Doug Williams, and Tom Wolfe

Sky subtraction is one of the major limitations to faint-object spectroscopy, especially at wavelengths where OH emission lines begin to dominate the sky spectrum ($\lambda > 6500\text{\AA}$). The ‘Nod-and-Shuffle’ observing mode, pioneered at the AAO by K. Glazebrook and J. Bland-Hawthorn, provides the ability of approaching the shot-noise limit for spectroscopy by greatly improving the sky subtraction over traditional techniques. The nod-and-

shuffle technique has now been implemented at the KPNO 4-m, where it is available for use with the T2KB and LB1A CCDs on the RC Spectrograph in a shared-risk mode during 2001B.

The nod-and-shuffle technique is described in detail by Glazebrook and Bland-Hawthorn (2001, *PASP*, in press; astro-ph/0011104), and interested readers are directed to this paper for a thorough discussion of the

technique’s pros and cons. In brief, the technique involves measuring the sky and object spectra quasi-simultaneously by offsetting (i.e. ‘nodding’) the telescope between object and sky positions while synchronously shifting (‘shuffling’) the charge on the CCD between the illuminated region and storage buffers (i.e., the unilluminated parts of the CCD). Since the charge can be ‘shuffled’ quickly and

continued



Optical Spectroscopy continued

non-destructively, many short observations of object and sky spectra can be recorded alternately, thus allowing the observer to sample the sky on timescales short enough to follow its variations. Moreover, the technique results in both object and sky spectra being recorded on the same pixels, through the same slitlets, and through the same optical path. This results in identical slit variations for both sky and object spectra, enabling a better sky subtraction

than is possible by traditional interpolation techniques. The nod-and-shuffle technique is also useful for spectroscopy of large extended objects (i.e., objects that fill a large fraction of the spectroscopic slit) where accurate sky subtraction is desired.

The penalty in using this mode is twofold—the noise in the sky estimate for each row is increased by root-two, and the observing time

overhead is larger due to the extra time spent observing sky plus the time spent nodding the telescope. However, the technique allows the observer to fill a slitmask with a large number of small slitlets, or, alternatively, to observe large extended objects without being limited by sky subtraction errors. In the multislit mode, the gain in the number of objects per mask and the improvement in sky subtraction jointly outweigh the loss due to the observing overheads and the larger sky noise. See Glazebrook and Bland-Hawthorn (2001) for details.

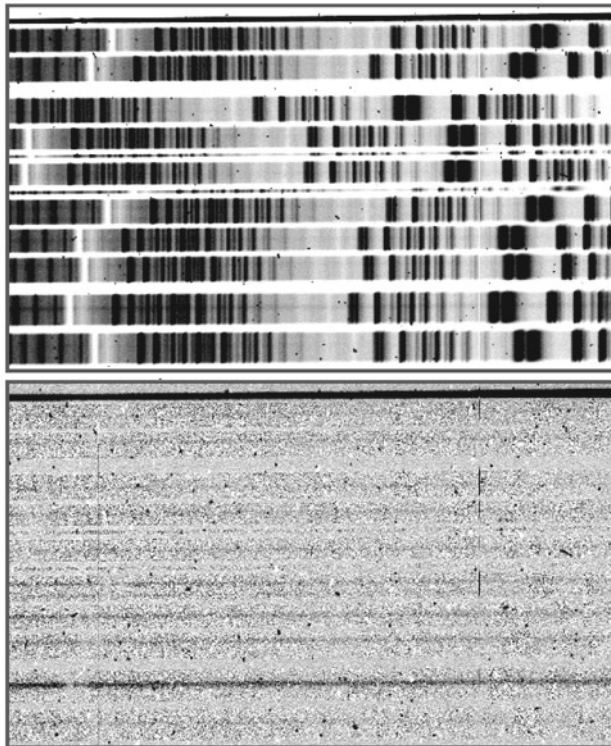

The upper panel shows a subsection of the raw CCD frame produced by the nod-and-shuffle mode. The lower panel shows the result of simply shifting the image by the shuffle offset and subtracting the shifted version from the original.

On the KPNO 4-m RC spectrograph, the nod-and-shuffle observing mode is available with the T2KB and LB1A CCDs. The T2KB CCD is more than three times larger than the field of view of the RC Spectrograph, and the full field is therefore available to the nod-and-shuffle mode. Hence, in principle, the 312" diameter slitmask can accommodate as many as 50 3.0" long slitlets with the minimum recommended 0.4-mm (2.65") inter-slit spacing. Note that the slitlet lengths need only be the size of an object (or its seeing profile) in the nod-and-shuffle mode.

The LB1A CCD, which is currently available in shared-risk mode with the RC spectrograph (see "Red Hot CCDs at KPNO!" in this newsletter), has a small format (1980 × 800) which requires a reduction in the number of simultaneously targetted objects. The observer can either use an

continued



Optical Spectroscopy continued

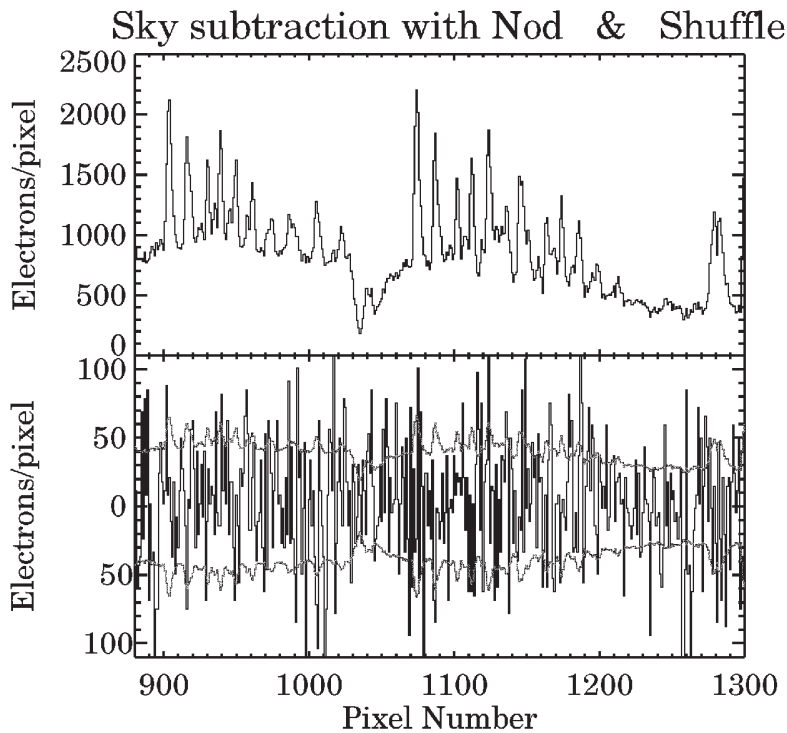

The effectiveness of the nod-and-shuffle technique is seen in a region of strong OH telluric emission (approx. 7180 - 8340 Å). The upper panel shows a single row of the raw CCD frame with strong OH features. The lower panel shows the same row after sky subtraction. Poisson noise from the sky is overplotted. The OH emission has been completely subtracted and the remaining "spectrum" is all sky noise.

FOV of 110" and densely pack slitlets as described above, or alternately, use the full FOV of 312" and leave dead space between slitlets for the storage region. Hence, although LB1A will provide far better red sensitivity than T2KB, the user will only be able to target between one-third and one-half the number of objects when using the nod-and-shuffle mode.

As of late January, the time overhead incurred by using this mode is large, since the overhead added by each telescope offset and guider acquisition is 15 sec. Hence, a 30-min exposure on target, subdivided into 60-sec integrations, takes a total of 75 min (not including the 2-min readout time of the T2KB CCD). We are currently investigating ways of reducing this overhead and will also implement the nod-and-shuffle mode with the new KPNO 4-m guider.

We are offering this observing mode on a shared-risk basis for the 2001B semester. Users interested in using this mode should contact Arjun Dey (dey@noao.edu) prior to their runs for the latest information.



USGP

U.S. GEMINI PROGRAM

Gemini Telescopes Update

Bob Schommer

The progress on the Gemini telescope project has been significant in the last few months, both in commissioning efforts and in science productivity. Among the highlights:

- Gemini South achieved first light in November with sub-arcsecond image quality even before any active optics were used.
- Gemini South achieved first guiding with the peripheral wavefront sensors in early January, and first calibration and implementation of the active optics was achieved.

- The final QuickStart runs on Gemini North were very successful in December. High-quality data were taken during the OSCIR run which ended mid-December and the Hokupa'a/QUIRC run over the Christmas holidays; overall 80% of the QuickStart proposals in the top two science rating bands had data taken and delivered to Principal Investigators.
- The 2001A schedule for Gemini North has been released and is available on the Web (<http://www.us-gemini.noao.edu/sciops/schedules/schedIndex.html>).

continued

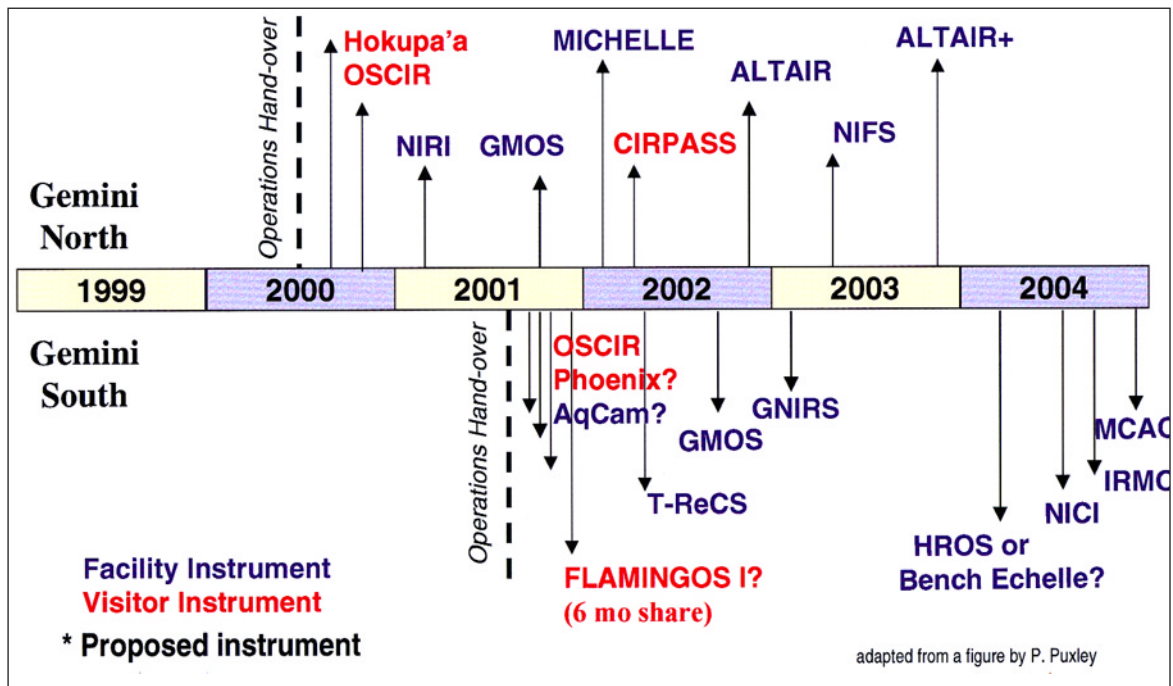

The above timeline represents when instruments are tentatively expected to be available for use by the Gemini community of astronomers (adapted from a figure by P. Puxley).



Telescope Update continued

Twenty-six proposals for the US succeeded in being scheduled for Gemini North in this semester, from 17 different US institutions. The total amount of telescope time allocated was 277 hours (~28 nights). This allocation was rather less than originally expected, due to the “payback time” associated with the use of visitor instruments on Gemini North over the past two years (combined with the difficulties, including poor weather, over the past semester in providing time to the instrument teams).

In particular, the amount of Hokupa’a/QUIRC time that was available to the US community was quite limited, and the oversubscription ratio was nearly 13:1 for that single instrument. All partners suffered similarly in this squeeze on time for the classical observing time. As a consequence, very highly rated proposals could not be scheduled this semester. We will attempt to compensate for this next semester. In particular, we have increased the allocation of Hokupa’a time available in 2001B and encourage investigators to resubmit the highly ranked, but to-date unscheduled proposals.

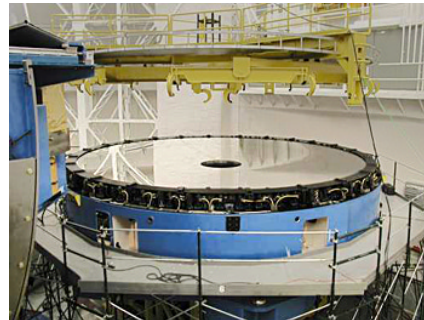

The newly coated primary mirror at Gemini South.

US Gemini Instrumentation Program Update

Taft Armandroff and Mark Trueblood

The US Gemini Instrumentation Program is responsible for the US instrumentation efforts for the Gemini telescopes. Instrument design and construction are underway in-house at NOAO and in the wider community. This article gives their status as of mid-January.

NIRI is a 1-5 μm imager with three pixel scales, designed and built by Klaus Hodapp and his team at the University of Hawaii. NIRI passed its Pre-Ship Acceptance Test in Honolulu in May 2000. Since then, NIRI has been undergoing lab testing at the Gemini North Base Facility in Hilo and telescope testing on Gemini North. These efforts have resulted in a characterization of NIRI’s on-telescope performance. Also, some

residual issues with instrument performance have been resolved, notably the elimination of a flexure problem. A team of controller and detector experts from NOAO traveled to Hilo in December and successfully carried out the 1-frame-per-second upgrade to the NIRI array controller. Final acceptance testing of NIRI is planned for March. IGP hopes that NIRI will be available for queue scheduled observing starting in April 2001.

T-ReCS, the Thermal Region Camera and Spectrograph, is a mid-infrared imager and spectrograph for the Gemini South telescope, under construction at the University of Florida by Charlie Telesco and his team. The T-ReCS optics have been mounted together and tested at room temperature, achieving good optical performance. Mechanical parts fabrication is essentially complete. The

continued

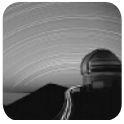

Program Update continued

dewar has been vacuum tested and has undergone, as of mid-January, two cold tests that have demonstrated good thermal performance. The team is in the midst of system integration and testing, which will culminate in T-ReCS's Pre-Ship Acceptance Test.

GNIRS, the Gemini Near-Infrared Spectrograph, is a long-slit spectrograph for the Gemini South telescope that will operate from 1 to 5 μm and will offer two plate scales and a range of dispersions. The project is being carried out at NOAO in Tucson under the leadership of Neil Gaughan (Project Manager) and Jay Elias (Project Scientist). Fabrication of GNIRS parts is underway at NOAO and at sub-contractor facilities. In particular, the construction of the GNIRS optical benches, that provide support for the optics and mechanisms, is nearly complete. A mid-fabrication review of GNIRS will occur on March 7.

NICI, the Near Infrared Coronagraphic Imager, is funded by monies from the NASA Origins Program to NOAO. NICI will provide a 1-5 μm infrared coronagraphic imaging capability on the Gemini South telescope. Mauna Kea Infrared (MKIR) was the successful competitive bidder for the NICI conceptual design study and the only respondent to an RFP for building the instrument. NOAO awarded a contract to MKIR in January for the detailed design and fabrication

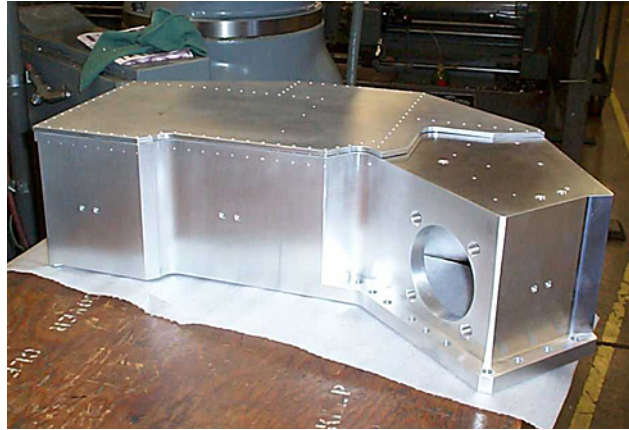

The GNIRS on-instrument wavefront sensor bench, in fabrication at NOAO. [This image can be found at <http://www.noao.edu/ets/gnirs/WFSBcover1.JPG>.]

of NICI. Milestones in the NICI contract include a preliminary design review in early 2002 and delivery to Gemini South in October 2004.

Phoenix is a high-resolution near-infrared spectrometer that has been in productive scientific use on the KPNO 4-m and 2.1-m telescopes. Phoenix yields spectra with resolution up to $R=70,000$ in the wavelength range 1 to 5 μm . Phoenix will be offered as a Visitor Instrument on Gemini South. Work is underway on modifying Phoenix for Gemini use. In particular, the fabrication of the interface unit and counterweights that will attach Phoenix to the Gemini Instrument Support Structure is underway at a subcontractor.

New Instrumentation Projects

It is possible that International Gemini may request proposals for study contracts for a new instrument during 2001: an Infrared Imager for the Multi-Conjugate Adaptive Optics System on Gemini South. When and if such opportunities are announced by International Gemini, USGP will advertise these opportunities within the US community and will encourage and assist interested US groups.



Status of Other Gemini Instruments

Bob Schommer

Here are some brief status reports on Gemini instruments being provided by other members of the international partnership. More details can be found in the Science Operations section of the Gemini Web site (<http://www.us-gemini.noao.edu/sciops/instruments/instrumentIndex.html>).

GMOS is the optical imager and multi-object spectrograph, a joint instrument project between Canadian and United Kingdom groups. The instrument is currently in testing and integration stages at the Astronomy Technology Center in Edinburgh. The current schedule is for the first GMOS instrument to be delivered to Gemini North in the April–May period, and we hope to make its capability available to the community for the 2001B semester on Gemini North in queue observing mode only.

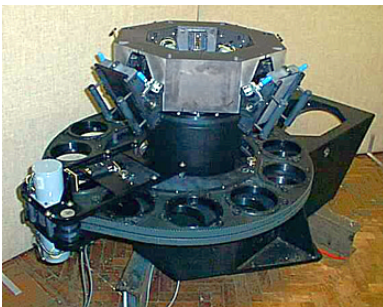

GMOS undergoes testing and integration at the UK Astronomy Technology Center.

CIRPASS is a near-infrared (0.9 to 1.5 μm) integral field unit (IFU) spectrograph under construction at the University of Cambridge and will be a visitor instrument at Gemini. The telescope beam goes through a changeable fore-optics which feed 499 hexagonal doublet lenses attached to fibers. The hexagonal lenses provide an area filling factor of 100% and project onto the sky in an elliptical arrangement. An OH suppression unit removes the majority of the telluric OH sky background, diminishes scattered light, and should provide significantly higher S/N than a conventional spectrograph. Estimated completion is Q2 2001, with commissioning on Gemini North in 2001B; it may possibly be available in the 2002A semester for science use.

ALTAIR is the facility natural guide star AO system for Gemini North, being provided by Canada. It will feed a variety of Gemini instruments. Current estimates are for it to be

available in 2002B, and possibly upgraded with laser guide star capabilities a year later.

NIFS is a near IR (1–2.5 μm) IFU spectrograph, designed to be AO-fed (3" IFU), destined for Gemini North. It is being constructed in Australia by ANU, and currently is expected for the 2003A semester.

HROS, the high dispersion optical spectrograph that was being designed for Gemini South by the UK community at University College, London, has encountered several levels of difficulty over the past year. It has recently been decided to modify the project and to deliver a higher dispersion, fiber-fed bench spectrograph. We will report on the options and status in the next newsletter.

How to Contact the US Gemini Program

The Web	http://www.noao.edu/usgp
Questions	gemini@noao.edu
E-mail a Staff Member	first initial+last name@noao.edu

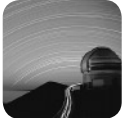

A Tip for Gemini Proposers

Caty Pilachowski

Gemini observing time has been highly oversubscribed, but a few simple strategies will optimize your chances for getting time. For the 2001A semester, the time available in the NIRI queue was not nearly as highly oversubscribed as for the classical time. Since this is likely to continue, investigators may be more successful with applications for queue observations. In queue mode, requests that can be done with worse-than-median observing conditions are even under-subscribed. Thus, savvy investigators will propose for queue observations that can be done in any conditions. While the Telescope Allocation Committee may give the highest grades to the most challenging observations, we cannot forward all of those programs on to Gemini. If you are more interested in getting data than in getting a high TAC grade, try proposing an easy program! Of course, good scientific merit counts, too, but even a very high grade won't guarantee that you'll get your data if you ask for only the best observing conditions.

See Todd Boroson's article in the September 2000 issue of the *NOAO Newsletter* for further discussion of how Gemini programs are selected.

Gemini Science at the Pasadena AAS Meeting

Caty Pilachowski (US Gemini Program Office) and Harvey Richer (Canadian Gemini Scientist)

The Canadian and US National Offices for the Gemini 8-m telescopes are jointly sponsoring a special session for the Pasadena meeting of the American Astronomical Society in June entitled "First Science Results from the Gemini North Telescope." Jean-René Roy, the Associate Director for Gemini North, will describe the scientific capabilities and instrumentation available at Gemini North, and expected at Gemini South. Additional speakers will tell us about

science results from the Demonstration Science observations of the Galactic Center with the Hokupa'a/QUIRC IR camera and adaptive optics system, and about science results from Gemini observations from the QuickStart service observing programs carried out in the Fall 2000 semester. Already data have been sent

to nearly 20 investigators for scientific programs ranging from a search for newborn planets to the stellar content of M33's bulge. June is an ideal time to highlight these first science results and to explore what can be done with the new telescopes and their suite of outstanding instruments.

The first scientific observations from the Gemini North telescope provide a dramatic glimpse into the elusive core of the Milky Way, including an intriguing bow-shock from a star as it plows into a poorly understood gas cloud a mere three light-years from the galactic center. (Photo: Gemini Observatory, National Science Foundation, and University of Hawaii Adaptive Optics Group.)

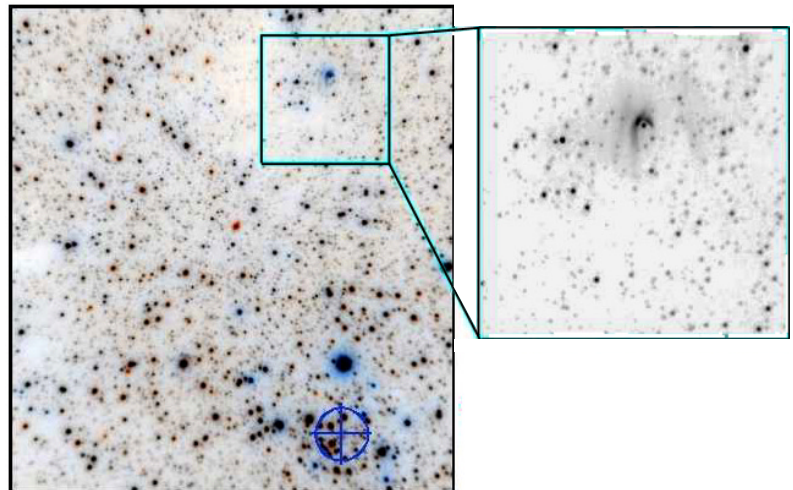



Let's Talk about Gemini

Bob Schommer

Gemini North is up and running, and Gemini South is on the way. The scientific opportunities offered by these outstanding new telescopes are extraordinary, and as the first two proposal rounds have shown, the US community is eager to take advantage of what Gemini can do. Learning about how to make use of Gemini and keeping up with the fast pace of new instrumentation, however, can be challenging. But USGP is here to help!

NOAO staff involved with the US Gemini Program are available to visit your institution to give colloquia and seminars on Gemini and to provide hands-on training

for submitting Gemini proposals and for learning to use the Phase II tool for planning observations. If you would like to schedule a visit from one of us, please contact the USGP Administrative Support Officer, Sally Adams, at sadams@noao.edu. We will do our best to schedule a visit by one of our staff.

In addition to presentations and training, visiting staff are interested in hearing your views on the future directions of Gemini. How can Gemini play a more important role in your scientific research? Visiting staff will also schedule discussion panels to explore future options for Gemini and to identify goals important to US astronomers.

US Participation in the International Gemini Project

Bob Schommer

The US participation in the International Gemini Observatory involves a broad range of activities, including on-going instrumentation efforts in the US community, science and instrumentation workshops, and input to the Gemini Observatory on operations and future directions. Two of the most direct channels to the project are the US Gemini Science Advisory Committee and the Gemini Board of Directors.

The US Gemini SAC, which comprises 11 members representing the broad US astronomical community, meets annually in person to discuss a broad range of issues.

The SAC defines the US position presented at meetings of the Gemini Science Committee, an international advisory committee to the Gemini Observatory Director.

The US SAC meets additionally throughout the year by telecon and e-mail. The membership of the US SAC is given on the USGP Web pages at <http://www.noao.edu/usgp/staff.html>. If you have concerns or questions about the US role in Gemini, please contact any member of the US SAC.

The Gemini Observatory is overseen by the Gemini Board of Directors, with representatives from each of the

Gemini Partner Countries. The US Members of the Gemini Board are appointed by the National Science Foundation. Currently, the US Board members are:

J. Gallagher (Wisconsin; Current Chair of the Gemini Board), M. Haynes (Cornell), A. Oemler (Observatories of the Carnegie Institution of Washington), and W. van Citters (National Science Foundation).

Concerns about the International Gemini project may also be shared with members of the Board.



National Solar Observatory

From the NSO Director's Office

Steve Keil and Mark Giampapa

NSO organized and participated in the submission of two major community proposals. A proposal for the design and development phase of the Advanced Technology Solar Telescope (ATST) was submitted to the NSF at the beginning of December, and a pre-proposal for developing a Virtual Solar Observatory (VSO) was submitted in mid-December. The ATST program is described in the December 2000 *NOAO-NSO Newsletter* and additional information can be obtained at the ATST Web site at <http://www.sunspot.noao.edu/ATST/>. If you'd like to read the proposal for the ATST, send an email to nso@noao.edu. The community-wide white paper that outlines the tasks and costs for developing a VSO was distributed in May 2000; it can be found at <http://www.nso.noao.edu/vso>.

The NSO Users' Committee met in December to review the NSO instrument program and discuss the impact of major projects on NSO operations. With the GONG upgrade, SOLIS, adaptive optics project, and ATST, discussion focused on NSO resources and our continued ability to support users at the telescopes. So far this has not been a major issue, but as observing setups become more complex to include adaptive optics and ever-increasing sophistication of focal plane instruments and cameras, we will

investigate ways to minimize the number of instrument changes. A "short" version of the Users' Committee report is included in this newsletter; the full text of the report is available on the Web at <http://www.nso.noao.edu/>.

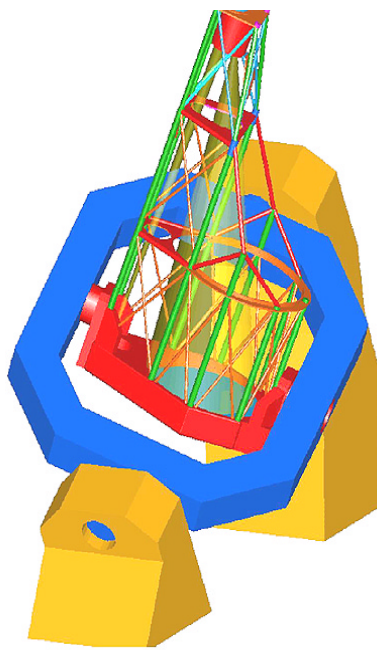

Artist's impression of an equatorially mounted off-axis ATST. A proposal for the ATST design and development phase is currently being reviewed for funding by the NSF.

NSO has started updating its long-range plans for the period FY 2002 through FY 2006. The current long-range plan for FY2001-FY2005 can be found at <http://www.nso.noao.edu>. Your comments and inputs into the formulation of the NSO plan are always welcome and can be sent to skeil@sunpot.noao.edu.

New Personnel

We're delighted to announce that Matthew Penn will be joining the scientific staff as an Associate Astronomer beginning in August 2001. Matt, who is currently a faculty member at California State University at Northridge (CSUN), is no stranger to NSO, having been a postdoc at Sac Peak and then a scientist in Tucson, where he contributed to the NASA support of the KPVT operations on Kitt Peak. While at CSUN, Matt has been actively involved in the development of a near-infrared solar observing program at San Fernando Observatory. Given his skill and experience with IR technology, Matt will play a key role in the implementation of IR instrumentation at NSO, including the development of a camera system based on an Aladdin 1024×1024 InSb array for use at NSO telescopes. In addition to his research interests, Matt is actively involved in educational outreach programs and

continued



Director's Office continued

in the establishment of collaborative programs with universities in research and education. Welcome back, Matt!

Krishnakumar Venkateswaran has joined the joint NJIT/NSO Adaptive Optics program as a Research Associate. He is employed by the New Jersey Institute of Technology and will be stationed at Sacramento Peak. Before joining the AO project,

Krishna worked in the Optical Sensors and Actuators Group at the Nanyang Technological University in Singapore for a year and at the Osservatorio Astronomico in Torino for six months. He obtained his Ph.D. from the Indian Institute of Astrophysics in Bangalore.

Sac Peak also welcomes Bill Denney, who is a part-time crafts helper working primarily with housing, and

John Briggs of the University of Chicago Engineering Center who is in residence at Sunspot and on contract with NSO to build, test, and deploy the site survey telescopes. Additional personnel changes in the GONG and SOLIS Projects are noted in the project write-ups that follow.

NSO Users' Committee Report

Tom Ayres (University of Colorado)

The NSO Users' Committee met at Sac Peak 5 - 6 December 2000. The current members are: T. Ayres (Chair, University of Colorado), T. Berger (Lockheed-Martin), T. Brown (HAO), G. Ginet (AFRL/VSBS, *ex-officio*), P. Goode (NJIT/BBSO), E. Hildner (NOAA/SEC), D. Jennings (NASA/GSFC), K.D. Leka (Colorado Res. Associates), D. Rabin (GSFC), E. Seykora (East Carolina), and D. Weedman (NSF, *ex-officio*). This was the first UC meeting since the beginning of the administrative separation between NSO and its former parent organization NOAO.

The Committee was unanimous in its praise of the NSO staff, who have been making remarkable progress on a number of fronts that ultimately will benefit the user community – in many cases putting aside their own research to bring these projects to fruition.

The separation of NSO from NOAO was a key issue: many facets still must be resolved, such as sharing costs of operating Kitt Peak and the engineering resources in Tucson, so the ultimate impacts on users remain to be seen.

NSO has several major projects in operation, upgrade, or development: SOLIS (long-term synoptic measurements of the Sun), GONG (helioseismology network), ISOON (Air Force space weather monitoring network), RISE/PSPT (precision solar irradiances), Infrared technology, Adaptive Optics, Virtual Solar Observatory (archival data), and ATST (advanced technology solar telescope).

The Solar Optical Long-term Investigation of the Sun (SOLIS) is in the construction and deployment phase. The Vector Spectro-Magnetograph (VSM) has suffered

a one-year delay owing to difficulties developing the critical high-speed CCD camera; an "interim" camera will permit SOLIS to be on line in 2002. The Global Oscillation Network Group (GONG) continues its nearly uninterrupted long-term helioseismology record, now into the maximum of the present sunspot cycle. Installation of new high-resolution cameras is expected by summer 2001, but funding must be sought to capture and process the expanded data stream.

At Sac Peak, the Adaptive Optics group has secured a grant from the NSF to develop a compensator that would fully correct images from the 76-cm Dunn Solar Telescope (DST). In the meantime, the existing 20-actuator system has become a heavily requested visitor instrument. Another popular facility—the HAO/NSO Advanced Stokes Polarimeter—is slated for a major upgrade by Fall

continued



User's Committee continued

2002 to utilize AO on the DST. An interim version might be available by the end of this year.

The RISE/PSPT network is complete, although operations support at Sac Peak and maintenance at all three sites remain unresolved issues. Sac Peak plays an engineering role in the Air Force's "ISOON," an enhanced version of an existing space weather monitoring network. Two of the four proposed units have been funded, but a hiatus after unit 2 is feared.

The infrared program at Kitt Peak has obtained an astronomical quality Aladdin InSb chip and is pursuing acquisition of a dewar and controller. Plans have been made to update the control system, and implement low-order AO, at the McMath-Pierce telescope. These improvements should substantially advance solar IR investigations. An upgrade of the McM-P East auxiliary telescope has been funded by NASA's Near Earth

Object program. The nighttime program suffered a setback with the loss of the observer (self-supported programs still are permitted). The highly successful solar digital library has evolved into a proposal for a Virtual Solar Observatory, a federation of geographically diverse archives tied together by a sophisticated data query/delivery system.

The program of perhaps greatest interest to NSO users is the Advanced Technology Solar Telescope. A proposal to develop a 4m-class off-axis solar telescope has been submitted to the NSF's Division of Astronomical sciences. Construction funding is not expected until later in the decade, pending solution of a number of thorny technical problems. For example, can current AO systems can be scaled to the larger aperture of the ATST? Can a suitable site be found; with excellent seeing to take full advantage of AO, and agreeable to all the partners? Can tens of kW

of heat be removed from the telescope without degrading image quality? (If ATST were sited in California, it surely would be recruited as a generating plant!)

Concern was expressed that NSO's recent success in securing new projects might draw expertise away from instrument development and support for existing telescopes, an area of immediate interest to current users. Director Keil faces a delicate balancing act to find the means to move steadily toward the goal to invigorate ground-based solar physics with a state-of-the-art facility by the end of the decade, while minimizing impacts on the highly productive science programs that NSO currently supports.

A more extensive version of this report is available at <http://www.nso.noao.edu/>.

A New Spectropolarimeter for the Dunn Solar Telescope

Michael Sigwarth, Thomas Rimmele, Steve Hegwer, Chris Berst, Scott Gregory, Kit Richards, and Larry Wilkins (NSO); Bruce Lites, David Elmore, and Kim Streander (HAO)

The HAO/NSO Advanced Stokes Polarimeter (ASP) is one of the most successful instruments that has operated at the Dunn Solar Telescope (DST) over the past decade. The ASP was designed for seeing-limited spatial resolution and is capable of an 80 × 170 arcsec field of view (FOV) coverage. The availability of adaptive optics has increased the demand for a polarimeter that enables observations at the diffraction limit of the DST.

In order to investigate the evolution of active regions, however, a larger FOV is necessary. The horizontal spectrograph that is currently used with the ASP does not allow for flexible image scales.

In an attempt to overcome these limitations, a collaboration between HAO and NSO was started in January 2000. The SOLAR-B concept model spectropolarimeter (CMSP), developed by HAO, will

serve as the basis for a new DST spectropolarimeter. HAO and NSO agreed to build a new spectrograph, including a new polarizing beam splitter (PBS). The new polarimeter will be named ASP-II, as in its first phase the new spectrograph will be operated from the existing ASP controller and use an ASP camera, the ASP modulator and calibration unit.

continued

Spectropolarimeter continued

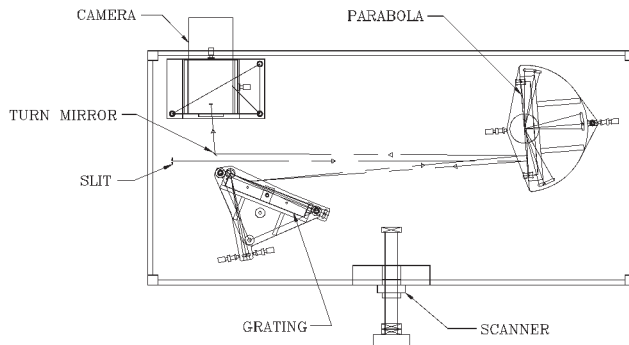

Schematic of the compact, diffraction-limited spectrograph for the Advanced Stokes Polarimeter II, a collaborative instrument by HAO and NSO. Not shown are the polarizing beam splitter (analyzer) that will be placed in front of the camera, the feed optics, and the slit-jaw camera. The spectrograph will be housed in a closed box with the heat load from the camera being kept out of the cover. To scan across a 2-D region of the Sun, the entire spectrograph is moved by the scanner. Design of the mechanical parts by Scott Gregory, NSO; optical design by David Elmore, HAO.

The unique feature of the compact spectrograph is that the grating is filled by the diffraction pattern from the 12- μm narrow slit so that the image scale can vary between 0.1"/pixel (high-resolution mode) and 0.35"/pixel (large-FOV mode) without significantly affecting the illumination of the grating. The resulting FOV will depend on the CCD camera used. ASPII will be limited to the spectral lines Fe I 630.15 and 630.25 nm, so it will not replace the classic ASP with its flexible wavelength setting.

A Memorandum of Understanding between HAO and NSO outlines the tasks and responsibilities during the current design and construction phase of ASPII, as well as its operation downstream. HAO is providing the optical design, the major optics parts including the PBS, mechanical parts from the CMSP, and one additional ASP-type CCD camera. NSO is contributing the grating and

is responsible for the design of a high-precision scanning mechanism, construction of the spectrograph including the scanner and all necessary mounts, and integration and operation of ASPII at the DST.

As of mid-January 2001, all major hardware was ordered and the spectrograph design 90% completed. The scanner will be driven by a servo-controlled DC motor with an encoder and will allow for a step size of 10 μm with a tolerance of 2 μm . This precision is required by the very narrow slit. Together with the NSO low-order AO system, ASPII will allow for occasional observations at the diffraction limit of the DST. The low sensitivity of the ASP camera will require integration times of about 10 sec in the high-resolution mode. The format of this camera will not allow for larger FOV than the current ASP. The first engineering run of ASPII is anticipated for the second quarter of this calendar year.

A PixelVision Pluto CCD camera was purchased in December 2000. The thinned, backside-illuminated chip of the Pluto offers more than twice the quantum efficiency of the current ASP camera and will allow for a 170×170 arcsec FOV in the low-resolution mode. The camera will be read out into digital signal processors (DSPs), which will allow for nearly-video frame rate and a fast demodulation of the Stokes parameters. The ultimate goal is to permanently install the ASP hardware with an independent polarimeter equipped with the Pluto camera and a high-order AO system. Permanent installation will eliminate the disadvantages of a flexible setup, and the high-order AO will increase the observing time with diffraction-limited spatial resolution. To achieve this goal, new groundwork is needed in polarization optics and for the controller system. The development of a Stokes polarimeter for the Advanced Technology Solar Telescope would benefit from the experience gained through this process.

The new Stokes polarimeter, including a new modulation and calibration unit, is expected to be available when the high-order AO system is completed. In the meantime, the Pluto camera will be available for the ASPII as soon as an interface to the "old" ASP is developed, sometime during the last quarter of this year.



SOLIS

Jack Harvey

The SOLIS project continues to make progress toward initial operational capability late in 2001. The first phase of the software that builds and controls the observing schedule is essentially complete. This software emphasizes instrument control, infrastructure, and communications. It allows semi-automatic operation of SOLIS by project personnel. The second phase has started, and it emphasizes user-friendly GUIs, data flow, and system integration. It will provide a more intelligent observation scheduler and observing time request support for the general community. The project is preparing to make its major computer hardware purchases in a few months.

At the same time that progress is being made on software infrastructure, control and data flow issues as well as data reduction algorithms are continuing to be developed. Most of the emphasis has been on the Vector Spectromagnetograph (VSM) since it generates the largest volume of data. Two visits by SOLIS personnel to the active group of researchers at the High Altitude Observatory established an excellent relationship. The HAO group is among the world's leaders in interpreting vector magnetogram raw data, so this association is highly beneficial for SOLIS. Long-term NSO visitor Takashi Sakurai (the National Astronomical Observatory of Japan), who completed his stay at NSO in December 2000, developed code intended to resolve

the so-called 180° ambiguity in vector magnetograph observations. His new technique uses both photospheric and chromospheric magnetograms. Roberta Toussaint, who recently moved from the GONG project to the SOLIS project as Data Scientist, is developing calibration techniques for the Integrated Sunlight Spectrometer (ISS) and the Full-Disk Patrol (FDP). Carl Henney has developed a prototype WWW page that will replace the existing NSO Synoptic Web page with new data products from SOLIS.

The SOLIS mount is temporarily located at the GONG prototype site in Tucson. All of the dozens of cables and hoses have been mounted in the 15-ton structure. Motor and tracking tests are underway. Preparations for moving the mount to the top of the Vacuum Telescope on Kitt Peak are under study.

The three major instruments are in various states of completion. The Vector Spectromagnetograph main support structure was received from a local machine shop, and this 1500-pound element is now mounted on its handling cart while all the mechanisms and components that it holds undergo trial fitting. A change was made to the grating mount mechanism that allows small tilts of the grating in order to maintain a fixed spectral focal position. One of the two axes was

controlled by a piezo pusher that turned out to not have enough push, and it was replaced by a precision screw and motor system identical to the other axis.

After a big effort, the optical shop that fabricated the VSM primary and secondary mirrors has successfully finished its work. Polishing the silicon secondary mirror required development of new techniques. These optics are now being readied for high-reflectivity silver coatings.

A long delay has been associated with slow fabrication and delivery of custom CCD cameras for the VSM. The vendor has undergone a major reorganization and now plans to produce usable CCDs by August 2001. A test pattern generator that simulates the camera signals was delivered, and the data acquisition system that accepts the signals is finished. A backup plan for acquiring interim camera systems was developed. SOLIS plans to proceed with procuring these cameras in late January 2001, pending the detailed response of the vendor to our request for quote.

The two 2K × 2K CCD camera systems for the FDP were received and are undergoing testing. Two birefringent filters for the FDP are under construction. The 1083-nm filter is nearly finished, while parts for the tunable 380-660 nm filter are still being built.



AAS Meeting Presentations by NSO 2000 REU and RET Participants

Mark Giampapa and Frank Hill

James Roberts and Travis Stagg, participants in the 2000 NSO Research Experiences for Undergraduates (REU) and Research Experiences for Teachers (RET) programs, made presentations at the January 2001 meeting of the American Astronomical Society in San Diego, California.

NSF/REU student James Roberts (Virginia Technical Institute) presented a poster, along with co-authors M. Giampapa (NSO) and E. Craine (GNAT, Inc.), entitled "Photometric Monitoring of M67 with the GNAT 0.5-m Telescope." James reduced and analyzed approximately 25 nights of unfiltered, CCD photometry of a portion of the M67 cluster which includes many solar-type stars. He presented the main results of this work, which were the measurement of the intranight and internight precisions that could be attained with the GNAT telescope and CCD. This project is a prelude to a long-term program to detect and characterize short-term and long-term, low-amplitude variability in the solar counterparts in M67. James made a valuable contribution toward this goal by developing a systematic approach to the reduction of the numerous CCD images that are obtained for this kind of long-term program.

Travis Stagg, a high school teacher from Girard College in Philadelphia who participated in the NSF Research

Experience for Teachers program in Tucson during the summer of 2000, was the lead author of a poster on "Real Research in the Classroom—Solar Active Longitudes." Travis' poster was co-authored by Mike Gearen, a high school teacher from Punahou High School in Honolulu, Suzanne Jacoby (NOAO), Harrison Jones (NASA/Goddard), Carl Henney (NSO), and Frank Hill (NSO).

Travis' poster reported on the development of a project to perform several different solar research projects in the classroom. Starting from a CD-ROM containing 23 years of Kitt Peak magnetograms, lesson modules, and software, students will be able to measure well-known phenomena such as the apparent change in the solar diameter, the differential rotation rate on the solar surface, the distribution of sunspots as a function of latitude and time (creating a butterfly diagram), and the dependence of the tilt of active regions as a function of latitude (Joy's law).

In addition, the CD-ROM will include software to enable the students to perform cutting-edge solar scientific research that should result in new knowledge. In this project, students will measure the latitude and longitude of many solar active regions, create a database of active region positions, and analyze the results to determine the location

of active longitudes (bands where activity tends to repeatedly occur). Measurements over the long time span of the observations will provide an estimate of the rate at which these zones rotate. This rotation rate is not necessarily the same as that seen on the solar surface because it is thought that active regions are connected to the material inside the Sun. Since we know how the solar interior rotates from helioseismology (the study of solar oscillations), comparing the rotation rate of the active longitudes to the internal rotation rate will allow us to determine how deep the active regions extend below the surface. This result, in turn, will provide clues about the origin of solar activity. The software and data are currently undergoing revisions to improve the quality of the data set, and to allow the software to run on any platform. We anticipate that the CD will be available for distribution in the fall of 2001.

Other undergraduate students from the NSO Summer 2000 REU program are looking forward to presenting the results of their research projects at the annual meeting of the AAS Solar Physics Division meeting in Boston in May.

Technique for Observation of Umbral Spectra in the Ultraviolet

Bill Livingston

Scattered light and the decrease of emissivity conspire to make the spectrum of a sunspot umbra difficult, if not impossible, to observe directly shortward of about 4000 Å. Sunspot spectral atlases (e.g., J. Harvey, 1977, or L. Wallace, et al., 2000) indicate that the umbra become identical to the photosphere in the violet. A partial solution is as follows. Observe the circular polarization (Stokes-*V*) signal that arises from the Zeeman effect and is therefore confined to the umbra. Integrating the Stokes-*V* yields a pure umbral Stokes-*I*, except that the zero level is lost and the continuum varies because of Stokes-*V* asymmetries. Also, of course, Zeeman insensitive lines are missed.

Jack Harvey (NSO), Neil Sheeley (NRL), Don Trumbo (Tucson), and Lloyd Wallace (NOAO) contributed to the project.

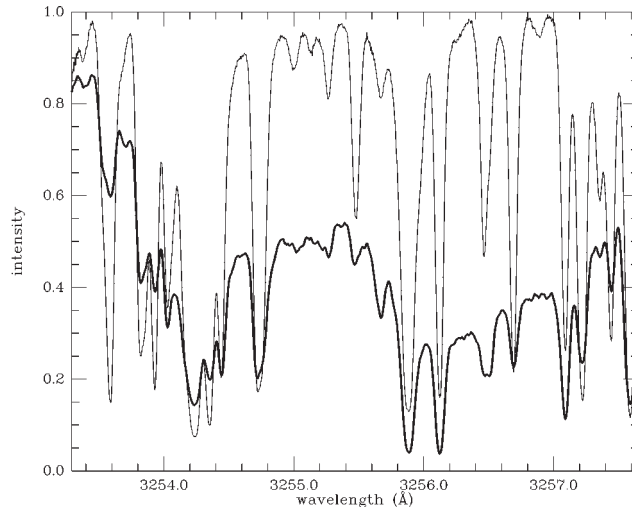

*Photospheric spectrum plus reconstructed umbral spectrum from digital integration of Stokes-*V* signal (bold). Identified lines: Fe (8), Mn (2), Cr II (1), OH (2), Sc (1). Unidentified (13 + blends). This region is being studied in a search for the molecule SH by Svetlana Berdyugina (University of Oulu, Finland). Note that most of the photospheric lines are present in the umbra, but their intensities are different. The all-reflective McMath-Pierce facility is well suited for such work, and we plan to explore other UV wavelengths where line blending permits.*

How to Contact the National Solar Observatory

The Web	http://www.nso.noao.edu
Questions	nso@noao.edu
E-mail a Staff Member	first initial+last name@noao.edu



NSO Observing Proposals

Dick Alrock

The current deadline for submitting observing proposals to the National Solar Observatory is 15 May 2001 for the third quarter of 2001, July-September. Forms and information are available from the NSO Telescope Allocation Committee at P.O. Box 62, Sunspot, NM 88349 for Sacramento Peak facilities (sp@sunspot.noao.edu) or P.O. Box 26732, Tucson, AZ 85726 for Kitt Peak facilities (nso@noao.edu). A TeX or PostScript template and instruction sheet can be e-mailed at your request; obtained by anonymous FTP from [ftp.sunspot.noao.edu](ftp://ftp.sunspot.noao.edu) (cd *observing_templates*) or [ftp.noao.edu](ftp://ftp.noao.edu) (cd *nso/nsoforms*); or downloaded from the WWW at <http://www.nso.noao.edu/>. A Windows-based observing-request form is also available at the WWW site. Users' Manuals are available at <http://www.sunspot.noao.edu/telescopes.html> for the SP facilities and <http://www.nso.noao.edu/nsokp/nsokp.html> for the KP facilities.

NSO Telescope/Instrument Combinations

Dunn Solar Telescope (SP):

- Echelle Spectrograph
- Universal Spectrograph
- Horizontal Spectrograph
- Universal Birefringent Filter
- Fabry-Perot Filter System
- Advanced Stokes Polarimeter
- Slit-Jaw Camera System
- Correlation Tracker
- Branch Feed Camera System
- Horizontal and Vertical Optical Benches
for visitor equipment
- Optical Test Room

Evans Solar Facility (SP):

- 40-cm Coronagraphs (2)
- 30-cm Coelostat
- 40-cm Telescope
- Littrow Spectrograph
- Universal Spectrograph
- Spectroheliograph
- Coronal Photometer
- Dual Camera System

Razdow (KP):

- H α patrol instrument

Hilltop Dome Facility (SP):

- H α Flare Monitor
- White-Light Telescope
- 20-cm Full-Limb Coronagraph
- White-Light Flare-Patrol Telescope (Mk II)
- Sunspot Telescope
- Fabry-Perot Etalon Vector Magnetograph
- Mirror-Objective Coronagraph (5 cm)
- Mirror-Objective Coronagraph (15 cm)

McMath-Pierce Solar Telescope Facility (KP):

- 160-cm Main Unobstructed Telescope
- 76-cm East Auxiliary Telescope
- 76-cm West Auxiliary Telescope
- Vertical Spectrograph: IR and visible gratings
- Infrared Imager
- Near Infrared Magnetograph
- CCD cameras
- 1-m Fourier Transform Spectrometer
- 3 semi-permanent observing stations for
visitor equipment

Vacuum Telescope (KP):

- Spectromagnetograph
- 1083-nm Video Filtergraph

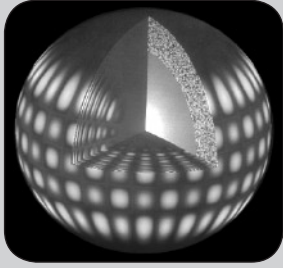

G O N G

Global Oscillation Network Group

GONG

John Leibacher

The Global Oscillation Network Group (GONG) Project is a community-based activity to operate a six-site helioseismic observing network, to do the basic data reduction and provide the data and software tools to the community, and to coordinate analysis of the rich data set that is resulting. GONG data are available to any qualified investigator whose proposal has been accepted. Information on the status of the Project, the scientific investigations, as well as access to the data, are available on our WWW server whose URL is <http://www.gong.noao.edu>.

October marked the fifth birthday of GONG's full network operations. The network continues to produce excellent data and maintain a high duty cycle through the full data processing pipeline. The GONG+ prototype testing continues, but the end is finally in sight. Following an upcoming Deployment Readiness Review, the first GONG+ system should be shipped to Big Bear in March. In addition to installing and verifying the functionality of the new system, we must be able to demonstrate that we can continue the low- to medium- ℓ p-mode program, and assess the two-site (Tucson/Big Bear) comparison and merging of the GONG+ high-resolution data. We should begin deployment to the other five sites in April, completing the effort by the end of July.

Operations

The GONG network continues to operate well despite the appearance of some annoying problems. The delay in the GONG+ deployment has caused a delay in preventive maintenance. The lack of periodic maintenance has resulted in downtime caused by the inability of the UPS to support the instrument during even brief power outages. Worse still, it appears that a low battery condition at the Learmonth site was actually inducing power glitches even when there was no clear drop in the utility power. Replacement batteries were obtained and installed by the site staff at Udaipur. Total system downtime because of failures and repair was about 54 hours. Replacement batteries had already been sent to Learmonth and

were awaiting the arrival of a PM team, but when the problems appeared, the site staff undertook the task of the installation. Approximately 39 hours of downtime resulted at Learmonth. We want to acknowledge the efforts of the staffs of both these sites for dealing with and resolving these problems.

Troubles with the half-wave plate rotator appeared in the El Teide instrument, causing a loss of synchronization of the timing system. Initial attempts to fix it looked promising for a time, but the problem would recur about four days after the system was disabled. After several weeks of this intermittent problem, an electronics change was made which caused the system to remain in the unsynced state, and to complicate matters, the video signal was lost. As the year came to a close, both El Teide and Tucson personnel were busy attacking these problems, which we are all pleased to have behind us now. At least five days of downtime resulted in November and December.

Because the new GONG+ computer has not yet been installed, we were quite aware that we would face a problem as the year changed to 2001. Preparations were made well in advance, and as the UT clock approached midnight, the appropriate changes were made and the transition went smoothly. The exception was the Udaipur site, which could not be reached via the Internet. Instructions that would allow them to handle the problem remotely were faxed and soon implemented. Nevertheless, about

continued



GONG continued

1.5 hours of downtime resulted at several of the network sites and more is expected, as tapes covering this time are yet to arrive.

Exabyte problems continued to occur around the network, causing about 46 hours downtime. As usual, downtime is meant to include the total time of the malfunction, whether or not it overlapped with poor weather, or the instrument was in the stow mode, or another site was providing good data. Therefore, the number of hours of lost images should be considerably less than the above value.

Weather too has been a factor this time of year. Big Bear has stowed the instrument due to severe weather for close to 12 days, and El Teide has suffered several days of weather-related downtime.

Data Management and Analysis

During the past quarter, the DMAC produced month-long (36-day) velocity, time series, and power spectra for GONG months 50 and 51 (ending 15 May 2000), with respective fill factors of 0.83 and 0.84, and tables of mode frequencies, which were computed from the power spectra using the three-month-long time series centered at GONG months 48, 49, and 50.

In addition to routine data reduction, the DMAC is actively involved in upgrading systems and applications for the reduction of GONG+ data and has routinely begun processing data acquired by the Tucson engineering test site through site day $\ell - v$ power spectra.

During the previous quarter, and in anticipation of the arrival of GONG+ data, the DMAC completed a long

overdue upgrade and replacement of four of the pipeline workstations and is in the process of planning the first round of GONG++ hardware.

Data Algorithm Developments

The new version of Peakfind developed by David Landy now incorporates two asymmetric line profile models. The asymmetry parameter measured using one of these models (Nigam-Kosovichev) is in good agreement with previous observations. The frequencies obtained using the asymmetric fit are now being studied and inverted to assess the impact on our conclusions about the solar interior.

Rudi Komm has implemented a new (to helioseismology) time series analysis package. Originally developed in

continued

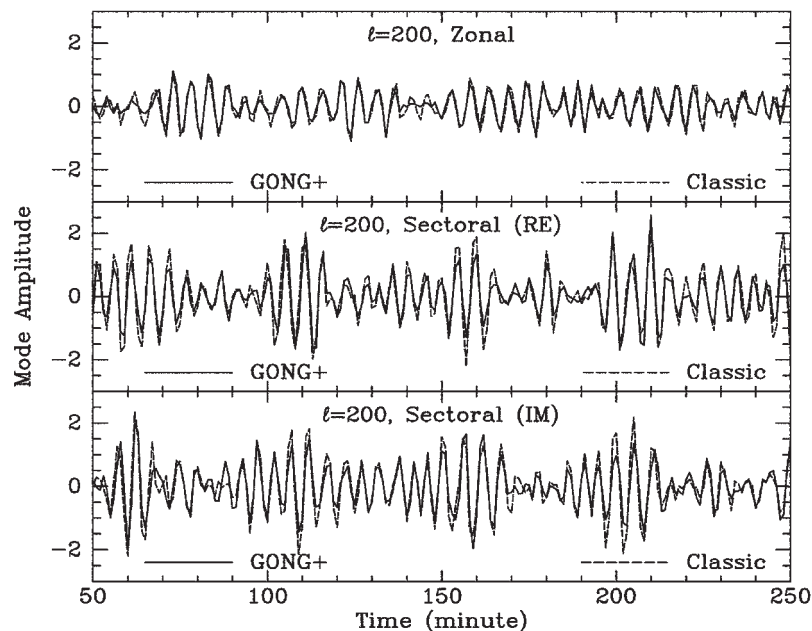

A set of detailed comparisons between GONG+, GONG Classic, and MDI images. The agreement is quite good, producing correlation coefficients around 0.9 for ℓ below 600 (GONG+ versus MDI). The figure shows excellent agreement between GONG+ and GONG Classic at ℓ of 200. This correlation strongly suggests that GONG+ and GONG Classic data can be successfully merged, which should improve the duty cycle during the transition to the new cameras.



GONG continued

oceanography, this method first seeks to determine a set of so-called empirical modes, which are derived from spline fits to the maxima and minima of a time series. These empirical modes are then subjected to a Hilbert transform, and the temporally varying amplitude and frequency are determined. The method has the potential of providing new insights into the excitation and damping of the oscillations. However, two technical details must be addressed before this can be done—the method must be extended to cope with gapped time series and with a complex-valued function.

Rachel Howe is developing a multi-dimensional regression analysis of helioseismic frequencies and several different activity indicators. Her results so far indicate that the relationship between the frequencies and the activity measures cannot be completely described by a linear relationship, but requires higher (and probably multiple) powers of frequency.

GONG+ Camera Development

A flaw in the SCSI interface of the GONG+ Data Collection System became evident during the final checkout at the Tucson engineering site, necessitating a suspension of our deployment schedule. At random times during the writing of accumulated data to the DLT tape drive, the system would crash and require operator intervention to restore normal operation. Fortunately, tape writing occurs after local sunset and permits us to implement ‘work-arounds’ that result in quick recovery and little to no loss of helioseismic data. Although this is disappointing, we are gratified that this problem revealed itself during testing rather than after deployment. We have initiated a series of tests to characterize the problem, determine the cause, and devise a remedy. Results so far suggest an obscure bug in the SCSI drivers, which are responsible for communications with the DLT tape drives.

As for the serial communications problem that we encountered last summer, we have developed error detection and recovery routines that enable a return to normal function with a minimal loss of data and little human interaction. If forced by constraints of time to proceed with deployment without fully correcting the cause of the problem, this ‘armor-plating’ will allow the commencement of GONG+ operations with little or no inconvenience to our site hosts.

The deployment components have been packed in crates and await transportation. After a four-week reliability run at the Tucson facility and a subsequent Readiness Review, our deployment teams will install the first system at the Big Bear site. The full network is scheduled for completion in July.

Personnel Changes

Susan Davidson, who has been with GONG for over six years, and NOAO for nearly 25 years, retired at the beginning of February. She will be missed throughout the GONG community, and we wish her the very best for the future. Roberta Toussaint, who has been with GONG for nearly a decade, has moved over to the SOLIS Project where she will be close by. We look forward to her continued association with GONG, including participation in the GONG+ deployment.

On the plus side of the ledger, we are delighted to welcome Guillermo Montijo back into the fold. Guillermo was a key player in the production and deployment of GONG Classic, and it is great to have him and his skills back on the team.

How to Contact GONG

The Web	http://www.gong.noao.edu
Questions	gong@noao.edu
E-mail a Staff Member	first initial+last name@noao.edu

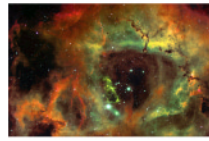

NOAO Public Affairs & Educational Outreach

Energized Team Effort Begins With Strong Impact at AAS

Doug Isbell

NOAO's educational and public outreach activities, and its interactions with the news media, have been brought together under a new manager, Doug Isbell, and a new organizational name—the Office of Public Affairs and Educational Outreach.

Suzanne Jacoby and Jane Price will continue their effective day-to-day management of our generally excellent outreach programs, and the scope of these programs will not change immediately. The goal is simply a more cohesive unit that shares its capabilities more effectively, and is more able to “speak with one voice” about NOAO's accomplishments and priorities, in outlets ranging from electronic press conferences to updated Kitt Peak visitor center exhibits.

With this spirit in mind, the office's staff took advantage of the 7–11 January 2001 meeting of the American Astronomical Society in San Diego to get off to an aggressive start for the year.

An entirely new display was developed for the exhibit area, featuring the first release of data from the NOAO Deep Wide-Field Survey (NDWFS). The seven foot-by-seven foot optical

image which served as the exhibit's focal point demonstrated the potential of the NDWFS to the astronomical user community in advance of the formal release of scientific data two weeks later, resulting in heavier-than-normal foot traffic in the NOAO exhibit. The display can be updated easily as research proceeds with NDWFS data, and it will likely be used as a backdrop for future public events, including Internet webcasting.

Two major new visual products were also distributed at the AAS meeting—a colorful educational poster about the solar spectrum and a bookmark featuring ten photos of NOAO facilities and related scientific imagery. The poster, in particular, was extremely popular with meeting attendees and educators from the American Association of Physics Teachers.

NOAO issued four press releases at the AAS meeting and helped support several press conferences, including a popular briefing on the first morning of the meeting by Gerry Williger of NOAO/NASA Goddard Space Flight Center regarding the discovery of a vast cluster of galaxies in the ancient Universe that produced

continued



©1999 Neelon Crawford

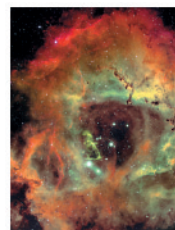

These six images cover one side of a new color bookmark developed by the NOAO Educational Outreach office as a handout for the public and for meetings and special events.



OUTREACH

Impact at AAS continued

wide media coverage in print (*Newsweek*, *USA TODAY*), radio (NPR, Voice of America), and television (CNN, ABC "Good Morning America"). The first Reuters news wire story of the meeting, on emerging plans for the National Virtual Observatory, featured two interviewees from NOAO.

Later that afternoon, National Solar Observatory Director Steve Keil and Gemini Project Director Matt Mountain participated in a well-attended media seminar on adaptive optics, organized by the National Science Foundation.

Looking ahead to the June 2001 AAS meeting, plans are underway for a major focus on early science from Gemini North.

MORE ON PUBLIC PRESENTATION OF NOAO NEWS, IMAGES AND SCIENCE

- AURA issued a news release on January 18 announcing the selection of Dr. Jeremy Mould as the next director of NOAO. This news was reported by the local *Arizona Daily Star* newspaper on Sunday, January 21, and later by *Nature* magazine. Media interviews with Dr. Mould are being planned for shortly after his arrival in Tucson.
- More than two dozen images have been added to the NOAO Image Gallery, including the NOAO DWFS exhibit image discussed above, other AAS-related images of planetary nebula Abell 39 [see photo caption] and a portion of M31 (from the NOAO survey program "Resolved Stellar Content of Local Group Galaxies Currently Forming Stars"), an image of M17 from the newly enhanced SQUID detector, the irregular star cluster M103 in the constellation Cassiopeia, and Supernova 1991N.

For more details, see:

http://www.noao.edu/image_gallery/new_additions.html



Planetary nebula Abell 39 was chosen for study by George Jacoby (WIYN Observatory), Gary Ferland (U. Kentucky), and Kirk Korista (Western Michigan U.) because of its beautiful and rare spherical symmetry. This picture was taken at the WIYN Observatory's 3.5-m (138-inch) telescope at Kitt Peak National Observatory, Tucson, AZ, in 1997 through a blue-green filter that isolates the light emitted by oxygen atoms in the nebula. This image was the subject of an NOAO press release during the January 2001 meeting of the American Astronomical Society, and it later received coverage by the Dallas Morning News, BBC On-Line, and space.com.

- Nick Suntzeff of CTIO appeared on the nightly Tucson KUAT-TV magazine show "Arizona Illustrated," on the evening before the premiere of a related PBS NOVA documentary episode titled "Runaway Universe," which featured footage and NOAO personnel from Cerro Tololo.

How to Contact NOAO Public Affairs

The Web Questions	http://www.noao.edu/outreach/press disbell@noao.edu Doug Isbell, Press Officer (520) 318-8214
E-mail a Staff Member	first initial+last name@noao.edu



PROJECT ASTRO NEWS

Suzanne Jacoby



Project ASTRO is a program that pairs professional and amateur astronomers with educators throughout the country to enhance astronomy education and increase students' interest in science. The fifth annual Project ASTRO-Tucson workshop held in October of 2000 brings to 250 the total number of ASTRO partners trained through NOAO's efforts.

For the 2001-02 school year, NOAO education programs will benefit from the University of Arizona fellowship program *Collaboration to Advance Teaching of Technology and Science* (CATTs), an NSF program for Graduate Teaching Fellows in K-12 Education (GK-12). Two graduate students (one astronomy, one computer science) funded by the CATTs program will work with staff in the NOAO Educational Outreach office to assist with the RBSE and ASTRO programs. During Spring 2001, they will observe and teach lessons in an ASTRO class, preparing them to assist with the Fall ASTRO workshop and to work as ASTRO partners for the 2001-02 school year. In Summer 2001 they will support our efforts to promote research-based science education, and prepare for presenting activities at the Fall 2001 ASTRO workshop.

Ginny Beal, Project ASTRO Site Coordinator, departed NOAO on January 31. Ginny has been an integral part of

the Educational Outreach efforts at NOAO since 1996. She has helped with all aspects of our program, including RBSE, ASTRO, REU, RET, information requests, image requests, and *everything else*. Her work with Project ASTRO-Tucson resulted in NOAO being a leader in the National Network of ASTRO sites, and in help for hundreds of ASTRO partners and thousands of students in the Tucson area. She has made valuable contributions to the EO program at NOAO and will be missed tremendously. Please join me in wishing Ginny well as she continues on life's journey.

Responsibilities for National Network Chair were transferred from NOAO-Tucson to the Boston Project ASTRO site at the beginning of 2001. You are encouraged to contact any of the ASTRO sites to get involved in science education through Project ASTRO, Educational and Public Outreach, and other opportunities.

continued



The Project ASTRO National Network exhibit featured student work as well as pictures of astronomers and educators working in the classroom. Central to the exhibit was a map showing the location and contact information for all eleven Project ASTRO sites in the network.



OUTREACH

ASTRO News continued

Contact information for the 11 Project ASTRO sites and National Project staff:

Boston, Massachusetts

Lead Institutions: Harvard-Smithsonian
Center for Astrophysics
& Boston Museum of Science
Tel: (617) 496-7867
Web site: <http://hea-www.harvard.edu/astro/>

New Jersey

Lead Institution: Raritan Valley Community
College
Tel: (908) 231-8805
Web site: <http://www.raritanval.edu/planetarium/astronova.html>

Chicago, Illinois

Lead Institution: Adler Planetarium &
Astronomy Museum
Tel: (312) 294-0343
Web site: <http://www.adlerplanetarium.org>

Connecticut

Lead Institution: Wesleyan University
Tel: (860) 685-3657
Web site: <http://www.astro.wesleyan.edu/~pastrol/>

Michigan

Lead Institution: Northwestern Michigan
College
Tel: (231) 946-1787
Web site: <http://www.nmc.edu/~rogers>

Ohio

Lead Institution: Ohio Space Grant
Consortium
Tel: (440) 962-3033
Web site: <http://www.osgc.org/page/ProjectASTRO.html>

Salt Lake City, Utah

Lead Institution: Hansen Planetarium
Tel: (801) 538-2104
Web site: <http://www.clarkfoundation.org/astro-utah/>

San Francisco, California

Lead Institution: Astronomical Society of the
Pacific
Tel: (415) 337-1100 x 101
Web site: <http://www.aspsky.org/astro/bay.html>

Seattle, Washington

Lead Institution: University of Washington
Tel: (206) 543-9541
Web site: <http://www.astro.washington.edu/projastro/>

New Mexico

Lead Institution: The Space Center, Alamogordo
Tel: (877) 333-6589
Web site: <http://www.nfo.edu/astro/>

Tucson, Arizona

Lead Institution: National Optical Astronomy
Observatory
Tel: (520) 318-8535
Web site: <http://www.noao.edu/outreach/astro>

National Project Staff

Andrew Fraknoi, Project Director
Erica Howson, National Project Coordinator
Project ASTRO National Office
Astronomical Society of the Pacific
390 Ashton Ave.
San Francisco, CA 94112
Tel: 415-337-1100 x 121
FAX: 415-337-5205
Web site: http://www.aspsky.org/project_astro.html



THE USE OF ASTRONOMY IN RESEARCH-BASED SCIENCE EDUCATION

Suzanne Jacoby

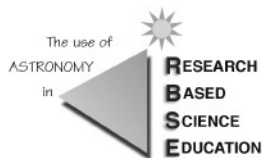

The NOAO Teacher Enhancement Program, the Use of Astronomy in Research-Based Science Education (RBSE), features a summer workshop and year-round support for middle and high school teachers who are interested in incorporating astronomy research within their science classes. RBSE extends the experience to the classroom with materials, data sets, support, and mentors during the academic year.

Our proposal to support the continued development of the RBSE Teacher Enhancement Program was submitted to the NSF Education and Human Resources Teacher Retention and Renewal Program in October. The new program would include development of a RBSE Distance Learning course, which would allow teachers who do not attend the summer workshop to use effectively the materials and pedagogy in the classroom. We have been contacted by the NSF/EHR Program Director and submitted revised budget sheets, often a sign that the proposal has done well in review and will be funded at some level. Updates to this situation will be posted at the RBSE Web site <http://www.noao.edu/outreach/rbse/> and in next quarter's newsletter article.



A group of participants in NOAO Educational Outreach programs is shown in front of a new exhibit on the NOAO Deep Wide-Field Survey, which was the featured element of NOAO's booths at the January AAS/AAPT meeting. From left to right (front): Travis Rector and Suzanne Jacoby (NOAO); (back) Travis Stagg (Girard College, PA; RBSE/NSO RET), Howard Chun (Cranston High School, RI; RBSE/KPNO RET), Ardis Maciolek (Grosse Point North High School, MI; RBSE/NRAO RET), Stan Hart (Pinson Valley High School, AL; RBSE/KPNO RET), Rob Welsh (Carver High School of Science & Engineering, PA; RBSE/NRAO RET), Rick Donahue (Eastchester Middle School, NY; RBSE/KPNO RET), Cindy Weehler (San Antonio, TX; RBSE/KPNO RET), and Wayne Sukow (NSF/EHR Program Director).



KPNO REU 2000 STUDENTS AT THE AAS WINTER MEETING

Kenneth Mighell

Seven of last summer's participants in the National Science Foundation's Research Experiences for Undergraduates (REU) program at Kitt Peak National Observatory attended the 197th meeting of the American Astronomical Society in San Diego, 7–11 January 2001, thanks to the generous support of the NSF.

The students presented posters on the various research projects they conducted during their 12-week stay at KPNO during the summer of 2000. Michael Cooper (Grinnell), Stuart Corder (Kansas), Heather Groch (Brown), Abigail Hedden (Carleton), Karin Sandstrom (Harvard), and Virginia Ponce (Virginia) were the first authors of six posters; Christopher Greer (Northwestern) and Abigail Hedden were co-authors on an additional three posters. The students attended the AAS Undergraduate Reception, as well as the opening reception on the night before the main part of the meeting started. They also listened to the oral sessions

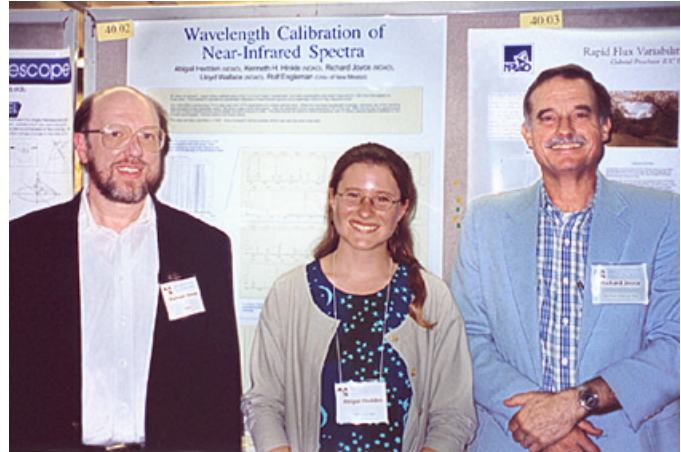

Ken Hinkle and Dick Joyce of NOAO are shown with KPNO REU student Abigail Hedden of Carleton College at the AAS meeting in San Diego. Hedden is currently a senior planning to attend graduate school in astronomy. The results of her REU project on wavelength calibration for near-infrared spectra have been accepted for publication by the Astronomical Society of the Pacific.

and the various town meetings, and participated in social events such as the banquet and the special lunch in honor of Margaret Burbidge on Thursday.

We hope to see our KPNO 2000 REU students presenting the results of their graduate studies at future AAS meetings.

How to Contact Educational Outreach	
The Web Questions	http://www.noao.edu/outreach sjacoby@noao.edu Suzanne Jacoby, Education Officer (520) 318-8364
E-mail a Staff Member	first initial+last name@noao.edu

NOAO Preprint Series

The following preprints were submitted during the period December 2000 through early February 2001. Please direct all requests for copies of preprints to the NOAO author marked.

- | | | | |
|-----|---|-----|---|
| 886 | Bower, G.A., *Green, R.F., Bender, R., Gebhardt, K., *Lauer, T.R., et al., "Evidence of a Supermassive Black Hole in the Galaxy NGC 1023 from the Nuclear Stellar Dynamics" | 888 | *Pilachowski, C.A., "The Old Giants in Globular Clusters" |
| 887 | Povich, M.S., Giampapa, M.S., Valenti, J.A., Tilleman, T., *Barden, S., Deming, D., *Livingston, W.C., Pilachowski, C., "Limits on Line Bisector Variability for Stars with Extrasolar Planets" | 889 | *Keller, C.U., "Instrumentation for Astrophysical Spectropolarimetry" |

Other NOAO and NSO Papers

Preprints that were not included in the NOAO preprint series but are available from staff members are listed below.

- | | |
|--|--|
| Antia, H.M., Basu, S., *Hill, F., Howe, R., Komm, R.W., Schou, J., "Solar-Cycle Variation of the Sound-Speed Asphericity from GONG and MDI Data 1995-2000" | Doyle, J.G., Jevremovic, Short, C.I., Hauschildt, P.H., *Livingston, W.C., Vince, I., "The Mn I 5432/5395 Å Line Formation Explained" |
| Beck, J.G., Ulrich, R.K., *Hill, F., Bogard, R.S., "Supergranule Lifetime and Angular Momentum Transport" | Gonzalez, D., Olofsson, H., *Schwarz, H.E., Eriksson, K., Gustafsson, B., "Imaging of Detached Shells around the Carbon Stars R Scl and U Ant through Scattered Stellar Light" |
| Berdyugina, S.V., Frutiger, C., Solanki, S.K., *Livingston, W.C., "The Molecular Zeeman Effect and Solar Magnetic Fields" | Haber, D.A., Hindman, B.W., Toomre, J., Bogart R.S., *Hill, F., "Daily Variations of Large-Scale Subsurface Flows and Global Synoptic Flow Maps from Dense-Pack Ring-Diagram Analyses" |
| *Blum, R. D., Damineli, A., Conti, P.S., "The Stellar Content of Obscured Galactic Giant HII Regions III: W31" | *Hill, F., "The Virtual Solar Observatory" |
| Corradi, R.L.M., *Schwarz, H.E., "Spatially Resolved Spectroscopy of the Outflow from the Symbiotic Mira RX Pup" | *Hill, F., Erdwurm, W., Branston, D., McGraw, R., "The National Solar Observatory Digital Library – A Resource for Space Weather Studies" |

Publications

*Hill, F., Ladenkov, O., Ehgamberdiev, S., Chou, D.-Y., "High-Frequency Multi-Wavelength Acoustic Power Maps"

*Hoard, D.W., *Wachter, S., Kim-Quijano, J., "Optical Photometry of the Double-Lined Cataclysmic Variable Phoenix 1"

*Howe, R., Hill, F., Komm, R.W., Christensen-Dalsgaard, J., Munk Larsen, R., Shou, J., Thompson, M.J., Toomre, J., "Interior Solar-Cycle Changes Detected by Helioseismology"

Jensen, J.B., Tonry, J.L., Thompson, R.I., Ajhar, E.A., *Lauer, T.R., Rieke, M.J., Postman, M., Liu, M.C., "The Infrared Surface Brightness Fluctuation Hubble Constant"

*Komm, R.W., Howe, R., Hill, F., "Width and Energy of Solar P-Modes Observed by GONG"

*Komm, R.W., Howe, R., Hill, F., "The Solar Cycle Is More Than Skin Deep!"

*Komm, R.W., Howe, R., Hill, F., "Background Amplitudes of Solar P-Modes Observed by GONG"

*Komm, R.W., Howe, R., Hill, F., "Exploring Time Series Analysis Techniques"

*Komm, R.W., Howe, R., Hill, F., "Width and Energy of Solar P-Modes Observed by GONG 1995-1999"

*Livingston, W.C., Berdyugina, S., "Umbral Spectra in the Ultraviolet via Molecular V-Stokes"

Nowotny, W., Kerschbaum, F., *Schwarz, H.E., Olofsson, H., "A Census of AGB-Stars in Local Group Galaxies. I. Photometry of a Field in M 31"

Nowotny, W., Kerschbaum, F., *Schwarz H.E. "A Search for AGB Stars in Local Group Galaxies"

Peterson, R.C., Terndrup, D.M., Sadler, E.M., *Walker, A.R., "Hot Horizontal Branch Stars in the Galactic Bulge. I."

Rhode, K.L., Zepf, S.E., "The Globular Cluster system in the Outer Regions of NGC 4472"

Romano, L.M., Corradi, M.L., Balick, B., Munari, U., *Schwarz H.E. "The Southern Crab from a New Perspective"

Scherb, F., Smyth, W.H., Freed, M.E., Woodward, R.C. Jr., Marconi, M.L., Lupie, O.L., Morgenthaler, J.P., "Sunlit Io Atmospheric [O I] 6300 Å Emission and the Plasma Torus"

Stenflo, J.O., Gandorfer, A., Wenzler, T., *Keller, C.U., "Influence of Magnetic Fields on the Coherence Effects in the Na, D, and D₂ Lines"

Table of Contents



NOAO Highlights

Treasure Hunt in the Sun's Neighborhood	3
First Data Release from the NOAO Deep Wide-Field Survey	4
Solar Magnetic Fields—Application of Adaptive Optics Offers New Insights.....	5

Director's Office

From the AURA President	7
Back to the Future	7
Sidney Wolff: Architect of the Future	8
The First Workshop on the Ground-Based O/IR System: Report Now Available	9
“Science with LSST”—A Report on the Workshop ..	10
NOAO Publication Lists Now Online	11

Observational Programs

2001B Gemini Proposals	12
Keck/NIRSPEC Time Going, Going,	12
The Status of the Hobby-Eberly Telescope	13
HET High-Resolution Spectrograph Status Report ..	14
Community Access Program Continues on the MMT	14
HET Low-Resolution Spectrograph Status Report ..	15
2001B Proposals for the WIYN-Operated 0.9-m Telescope on Kitt Peak	15
Four SIRTf Legacy Proposers Win NOAO Time	16
Coudé Spectrograph Available at DAO	16
NOAO Nighttime Proposals Due for 2001B	17
CTIO Instruments Available	19
HET Instruments Available	20
Gemini Instruments Possibly Available	20
KPNO Instruments Available	21
MMT Instruments Available	22

CTIO Operations

Site Survey for the GSMT	23
Light Pollution Control in Chile	25
SOAR Update	27
CTIO Telescopes and Instruments Available for Semester 2001B	28
Mosaic II Now with 16 Channels	28
Tom Ingerson Leaves CTIO	30
New Rates at the AURA Observatory	30

KPNO Operations

WIYN to Operate the Kitt Peak 0.9-m Telescope: NOAO Users to Gain Continuing Access to Mosaic.....	32
--	----

KPNO Operations (continued)

FLAMINGOS Successful Commissioning.....	33
Upgrading the Cryogenic Camera	35
Red Hot CCDs at KPNO	37
Quick & Dirty CCD Stellar Photometry	39
Did You Ever Feed the Coudé?	40
Optical Spectroscopy Learns the Nod-and-Shuffle ..	41

US Gemini Program

Gemini Telescopes Update	44
US Gemini Instrumentation Program Update	45
Status of Other Gemini Instruments	47
A Tip for Gemini Proposers	48
Gemini Science at the Pasadena AAS Meeting	49
Let's Talk about Gemini	49
US Participation in the International Gemini Project	49

National Solar Observatory

From the NSO Director's Office	50
NSO Users' Committee Report	51
A New Spectropolarimeter for the Dunn Solar Telescope	52
SOLIS	54
AAS Meeting Presentations by NSO 2000 REU and RET Participants	55
Technique for Observation of Umbral Spectra in the Ultraviolet	56
NSO Observing Proposals	57
NSO Telescope/Instrument Combinations	57

GONG	58
------------	----

NOAO Educational Outreach

Energized Team Effort Begins with Strong Impact at AAS	61
Project ASTRO News	63
The Use of Astronomy in Research-Based Science Education	65
KPNO REU 2000 Students at the AAS Winter Meeting	66

Publications

NOAO Preprint Series	67
Other NOAO and NSO Papers	67