

# >>> NOAO/NSO Newsletter

NATIONAL OPTICAL ASTRONOMY OBSERVATORY/NATIONAL SOLAR OBSERVATORY

ISSUE 95 – SEPTEMBER 2008

## Science Highlights

Echoes of Galactic Supernovae.....	3
Observations of a Small Emergent Bipolar Flux Region.....	5
Carbon-enhanced Metal-poor Stars and the	
Chemical Evolution of the Early Galaxy.....	6
Do Solar Subsurface Vorticity Measurements	
Improve Flare Forecasting?.....	7

## Director's Office

First Thoughts and Early Priorities.....	9
The GSMT Chicago Workshop – First Steps Toward	
a National Design Reference Mission.....	10
LSST Mirror Unveiled.....	11
ALTAIR Committee and Survey.....	11
Building the ReSTAR System.....	12

## NOAO Gemini Science Center

Gemini Classical and Queue Observing Opportunities	
for Semester 2009A.....	13
Suitable 2009A Gemini Queue Programs	
May Be Offered Classical Time.....	14
The Personal Contact Option for the	
Gemini HelpDesk.....	15
The Joint Subaru/Gemini Conference “Cosmology	
Near and Far: Science with WFMOS”.....	15
The Gemini/Subaru Wide-field Fiber Multi-Object	
Spectrograph (WFMOS): An Update.....	16
Kyoto Joint Subaru/Gemini Science Conference	
in May 2009.....	16
Report of a Classical Gemini-Subaru Exchange	
Program Observing Run.....	17
Detailed Aspects of Technical Reviews for	
T-ReCS and Michelle.....	18
Gemini News from the Marseille SPIE Meeting.....	18
NGSC Instrumentation Program Update.....	20

## Observational Programs

2009A Observing Proposals Due 30 September 2008;	
Survey Proposals Due 15 September 2008.....	21
Community Access Time Available in 2009A	
with Keck, Magellan, and MMT.....	22
Observing Request Statistics for 2008B	
Standard Proposals.....	22
CTIO Instruments Available for 2009A.....	23
Instruments Expected to be Available for 2009A.....	24
KPNO Instruments Available for 2009A.....	25
MMT Instruments Available for 2009A.....	26
Magellan Instruments Available for 2009A.....	26
Keck Instruments Available for 2009A.....	26

## Data Products Program

Single Sign-on and the Virtual Observatory as	
an Operational Facility.....	27
The All-Sky Camera Project.....	27
Upcoming Data Products Program Meetings	
and Events.....	29

## Cerro Tololo Inter-American Observatory

Fiber Echelle Spectrograph Finds New Life	
as Exoplanet Hunter.....	30
Progress on the SOAR Adaptive Module.....	31
Blanco TCS Upgrade.....	32
Chile Staff Changes.....	32

## Kitt Peak National Observatory

The Meinel Partnership and the Founding of the	
National Observatory.....	33
Pierre Martin Succeeds George Jacoby as	
Director of the WIYN Observatory.....	34
Commissioning Work on WHIRC Proceeding Well.....	35
Update on KPNO Modernization Projects	
and Operations.....	36

## National Solar Observatory

Director's Corner.....	37
ATST.....	38
First Quarter Deadline for NSO Observing Proposals.....	38
SOLIS.....	39
First Lock for McMath-Pierce Planetary Adaptive	
Optics System.....	41
GONG++.....	42
International Research Experience	
for (Graduate) Students (IRES).....	44

## Public Affairs and Educational Outreach

US IYA 2009 Momentum Grows with House Resolution,	
Prototype of Image Exhibition.....	45
Another Successful Horse Camp on Kitt Peak;	
KOHN Show Debuts.....	45
CADIAS Participates in Show of Integrated Arts	
in Argentina.....	46
A Research Adventure for Tucson Educators.....	47



## Chris Smith Named Director of CTIO

R. Chris Smith has been selected as the next director of Cerro Tololo Inter-American Observatory (CTIO). Smith will succeed Alistair Walker in November. Walker will return to the scientific staff of CTIO after five years as director.

“Chris has years of experience working for CTIO, he has led a major southern-sky survey of the Magellanic Clouds, and he recently headed the NOAO-wide Data Products Program during a period of extensive developments in virtual observatories,” said NOAO Director David Silva. “I am confident he will excel in this new role as an observatory director.

“I thank Alistair for his excellent service as CTIO director during an exciting era when the Dark Energy Camera project for the Blanco 4-meter telescope was born, and the Large Synoptic Survey Telescope project chose a peak within the AURA compound in Chile for its future site,” Silva added. “Alistair has left the observatory extremely well positioned for the coming years.”

A co-recipient of the 2007 Gruber Cosmology Prize for his part in one of two teams that announced the discovery of the accelerating expansion of the Universe in 1998, Smith first joined CTIO as a postdoctoral student after earning a Ph.D. from Harvard University in 1991. He spent three years at CTIO, followed by three years at the University of Michigan before returning to CTIO as a staff astronomer in 1998.

Smith is the principal investigator of the Magellanic Cloud Emission Line Survey (MCELS), which mapped out the interstellar medium of the Large and Small Magellanic Clouds in the emission lines of hydrogen, oxygen, and sulfur to improve our understanding of the interactions between stars and the gas and dust which surrounds them.

“CTIO is a cornerstone of both the future of NOAO and, more generally, the future of U.S. astronomy. The facilities available today at CTIO, SOAR, and Gemini and the promise of the exciting next generation of facilities located in Chile, including ALMA, LSST, and GSMT are a magnificent combination,” Smith said. “I look forward to building upon the strong foundation and excellent staff we have in Chile to take full advantage of the exciting scientific opportunities the future holds.”

The NOAO-NSO Newsletter is published quarterly by the **National Optical Astronomy Observatory**  
P.O. Box 26732, Tucson, AZ 85726  
[editor@noao.edu](mailto:editor@noao.edu)

Douglas Isbell, Editor

### Section Editors

Abhijit Saha  
Dave Bell  
Mia Hartman  
Christopher J. Miller  
Nicole S. van der Blik  
Buell T. Jannuzi  
Ken Hinkle  
Sally Adams  
John Leibacher  
Jackie Diehl  
Douglas Isbell

Science Highlights  
Observational Programs  
Observational Programs  
Data Products Program  
CTIO  
KPNO  
NGSC  
NGSC  
NSO  
NSO  
Public Affairs &  
Educational Outreach

### Production Staff

Sheryl Falgout  
Peter Marenfeld  
Kathie Coil

Managing Editor  
Design & Layout  
Production Support

## On the Cover

### TWIN GALAXIES IN A GRAVITATIONAL EMBRACE

In what first appears to be a masterful optical illusion, astronomers at Gemini Observatory have imaged two nearly identical spiral galaxies in the Virgo cluster, 90 million light-years distant, in the early stages of a gravitational embrace. The image was obtained using the Gemini Multi-Object Spectrograph on the Gemini South 8-meter telescope in Chile.

Like two skaters grabbing hands while passing, NGC 5427 (the nearly open-faced spiral galaxy at lower left) and its southern twin NGC 5426 are in the throes of a slow but disturbing interaction—one that could take a hundred million years to complete. Together, the pair is known as Arp 271.

The two spiral arms on the western (upper) side of NGC 5426 appear as long appendages that connect with NGC 5427: this intergalactic bridge acts like a feeding tube, allowing the twins to share gas and dust with each other across the 60,000 light years of space. Colliding gases caused by the interaction have likely triggered bursts of star formation in each galaxy, as evidenced by the hot pink knots (HII regions) visible in both. The giant ones in NGC 5426 are curiously knotted and more abundant on the side of the galaxy closest to NGC 5427. Starburst activity can also be seen in the bridge connecting the galaxies.

*Credit: Gemini Observatory*

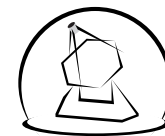

## Echoes of Galactic Supernovae

Armin Rest (Harvard University) & Chris Smith (NOAO)  
for the Echoes of Historical Supernovae (EHS) Team

Light echoes from ancient supernovae offer a unique and powerful opportunity to study supernovae and their relationships to supernova remnants (SNRs), as well as interstellar dust and Galactic structure. The use of this relatively simple phenomenon of light echoes in such studies is just now developing into an exciting new field of study. This is one of the very rare occasions in astronomy that the cause and effect of the same astronomical event can be observed, in that we can study the physics of the SNR as it appears now and also the physics of the explosion that produced it hundreds of years ago.

We define a light echo as reflected light from a light source, not reprocessed light. Similar to the muffled echo of sound when someone shouts something toward a wall, the light echo still contains the initial signature of the original light, even if the precise signature is somewhat modified by details of the reflecting surface. Since the reflected light traverses a longer path than the light that takes the direct path to the observer, it will be observed some time after the initial explosion is observed.

Our group pioneered the optical discovery and study of ancient supernova light echoes in the LMC, where three echo complexes were found to be associated with 400-900 year-old supernova remnants (Rest et al., 2005b). The spectra of one of those echoes (Rest et al., 2008a) allowed us to classify the event as a specific subtype of the Type Ia, which in this case was from an overluminous SN Ia. This was the first time that the type of a SN could be unambiguously determined based on the spectrum of maximum light of the supernova centuries after the light on the direct path had reached Earth.

Echo features similar to those we discovered in the LMC should be detectable within our own Milky Way—the challenge is to locate them across a much larger solid angle. For example, the angular distance between a light echo of a Galactic SN at a distance of 3,000 pc

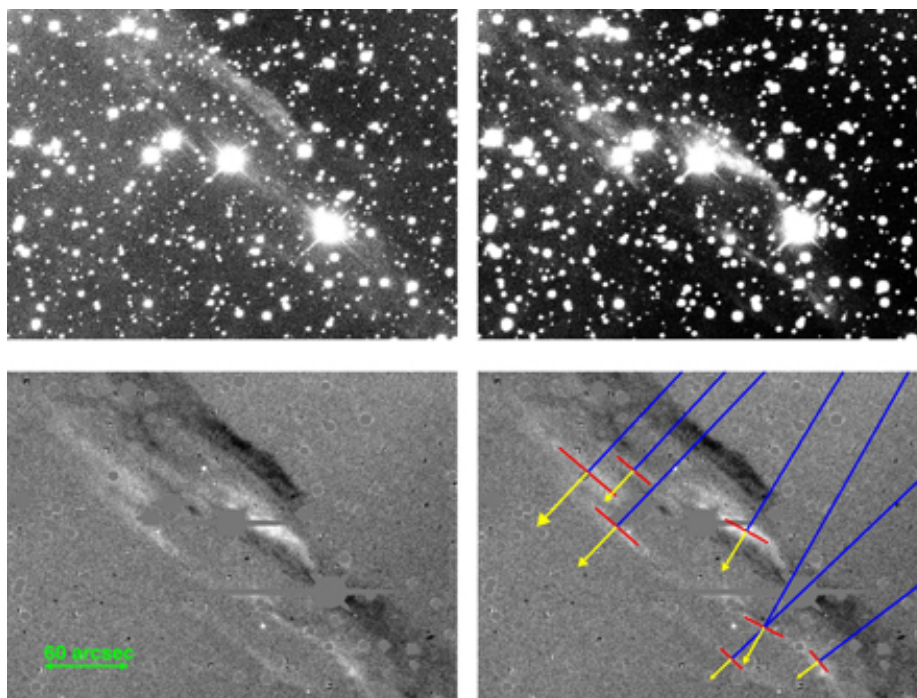

Figure 1

to the SNR may be tens of times larger than if the same SN and reflecting dust were located in the LMC. Thus the search annuli for light echoes of Galactic SNe can have an outer radius up to 20 degrees.

We have undertaken a program using the CTIO and KPNO 4-meter telescopes with the NOAO Mosaic imagers to find echoes around the seven certain historical Galactic SNe recorded in the last 2,000 years (Stephenson & Green, 2002): SN 185 AD/Centaurs, SN 1054 AD/Crab, SN1006 AD/Lupus, SN 1181 AD/Cassiopeia, Tycho, Kepler, and Cas A. Given the relatively well-constrained ages of these historical supernovae and estimated distances, we can improve our chance to find echoes by targeting regions of cold dust at the approximate expected angular distance. We used the reprocessed 100-micron IRAS images (Miville-Dechenes & Lagache, 2005) to select fields with lines of sight which contain such dust, choosing fields closer to

the Galactic plane than the supernovae in the expectation that dust would be more highly concentrated there. Two epochs of imaging data were kernel- and flux-matched, aligned, subtracted, and masked using the techniques developed for the LMC echo searches (Rest et al., 2005a).

Careful visual inspection of our clean difference images revealed many candidate echo arclets, such as those shown in figure 1. We estimated the individual arc-motion directions as shown in the figure, and grouped the clusters of arclets into echo complexes. To date, we have discovered two distinct echo complexes (panel A of figure 2). One complex consists of six clusters of light echoes with proper motion vectors converging back to the Cas A SNR, and the other complex is composed of six echo clusters with an origin coincident with the Tycho SNR (Rest et al., 2008b). Panel B shows the average vector for each light echo cluster. Krause et al. (2008)

*continued*

*Echoes of Galactic Supernovae continued*

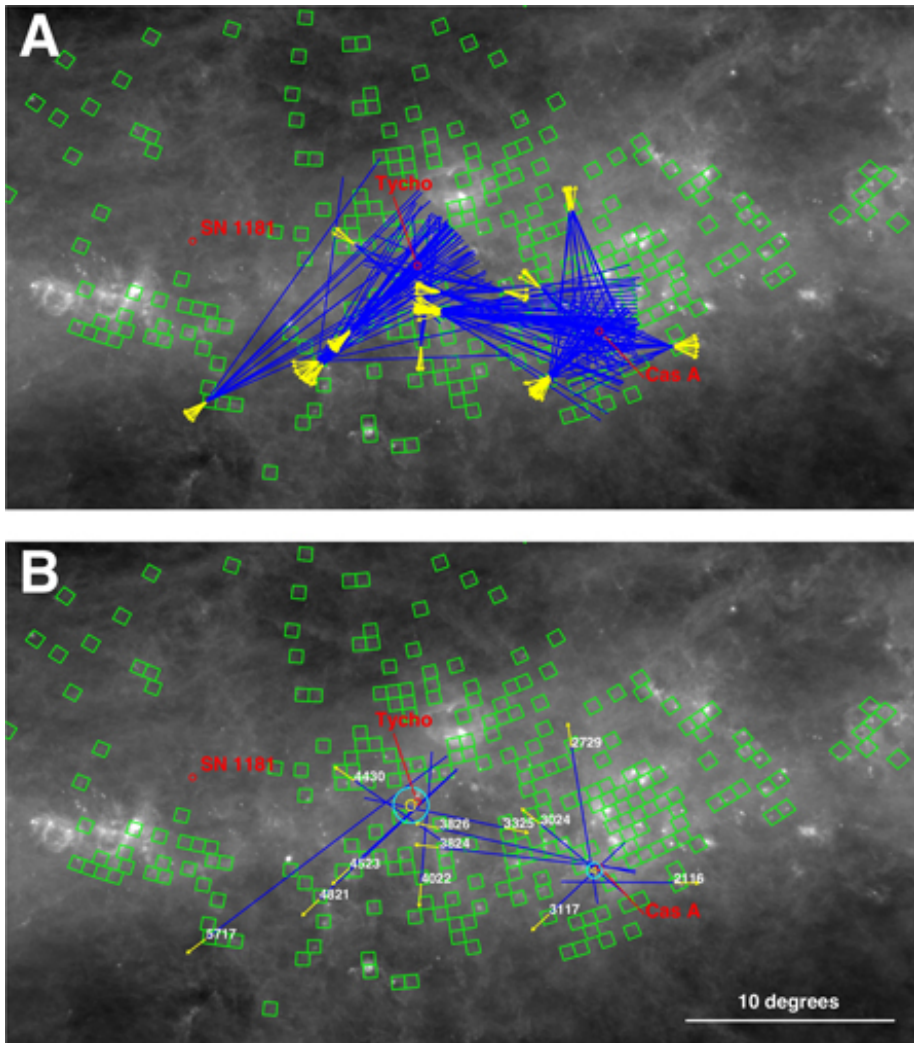

Figure 2

have also discovered an apparent light echo from Cas A at a much smaller apparent angular distance from the remnant.

These scattered-light echoes from Galactic SNe provide a host of newly-recognized observational benefits:

- **SN type classification:** For Cas A, Krause et al. (2008) have obtained a spectrum of the echo they discovered, which indicates a classification of Type IIb for the SN. We hope to obtain spectroscopy of several more Cas A echoes to obtain confirmation.

For Tycho, we hope to determine the SN Ia subtype with our follow-up spectroscopy.

- **Distance to the SNR:** The *geometric* distance to the source of light echoes can be determined to high accuracy with polarization measurements of its light echoes (Sparks, 2008). This method works best for light echoes with a scattering angle spread around 90 degrees, which corresponds to a distance spread around  $z=0$ , where  $z$  is the distance from the supernova to the scattering dust projected along our line of sight. This is the case for the echoes we have

discovered from Tycho. For Cas A we need several more light echo groups closer to the SNR. The existence of re-radiated echo light in the infrared (Krause, 2005) suggests that further scattered-light echoes closer to Cas A should be detectable.

- **Asymmetry of SN explosion:** Light echoes offer another rare occasion in astronomy, in that the spectra of echo arcs at different position angles is equivalent to different hemispheres of the photosphere. Tycho is a perfect candidate for this study: we will be able to look at Tycho from *opposite* sides due to the favorable locations of the scattering dust! Testing the asymmetry of SN Ia is very important for our understanding of the physics of these explosions, especially given that Type Ia SNe are used as cosmological standard candles.

Beyond these supernova-related benefits, complexes of light echoes can help us map out and understand the structure of dust sheets in the Galaxy, and possibly understand the characteristics of the dust itself. With further observations of the regions around historical supernovae, we hope to find more examples of these exciting “ghosts,” which move through the sky with apparent motions of 20 to 40 arcsec per year.

Note: The discovery paper of the Cas A and Tycho echoes was dedicated to Howard Lanning, a valuable member of the “Echoes of Historical Supernovae” team who passed away on 20 December 2007. 

REFERENCES

Krause, O., et al. 2008, *Science*, in press  
 Krause, O., et al. 2005, *Science*, 308,1604  
 Miville-Deschenes, M.-A. & Lagache, G. 2005, *ApJS*, 157, 302  
 Rest, A., et al. 2005a, *ApJ*, 634, 1103  
 Rest, A., et al. 2005b, *Nature*, 438, 1132  
 Rest, A., et al. 2008a, *ApJ*, 680, 1137  
 Rest, A., et al. 2008b, *ApJL*, 681, 81  
 Stephenson, F. R., & Green, D. A. 2002, *Historical Supernovae and Their Remnants*, International Series in Astronomy and Astrophysics, vol 5. Oxford: Clarendon Press, 2002, ISBN 0198507666  
 Sparks, W. B., et al 2008, *AJ*, 135, 605

# Observations of a Small Emergent Bipolar Flux Region

Alexandra Tritschler (NSO), Kevin Reardon & Gianna Cauzzi (Arcetri Observatory)

The Sun has not been very active lately, with only a handful of active regions appearing on the disk in many months. For this reason, we are excited about being able to capture the emergence phase of a small, old-cycle, bipolar region close to disk center on 22 April 2008. During almost four hours of exceptionally good seeing conditions, the Interferometric Bidimensional Spectrometer (IBIS) scanned repeatedly through four spectral lines (Fe I 709.04 nm, Na I 589.6 nm, H I 656.3 nm, Ca II 854.21 nm), covering the height range from the photosphere to the chromosphere. The narrowband observations are supported by simultaneous broadband observations at 721 nm and in the G Band around 430.5 nm. The small bipolar region was not visible in the late afternoon on the previous day, and decayed completely during the two days following our observations.

Although IBIS was operated in a non-polarimetric mode, these observations are of particular interest and importance for two reasons. First, we witnessed the transformation of filamentary structures (a rudimentary penumbra) into a small but fully developed penumbral segment in the photospheric layers of one of the formerly naked umbrae, in concert with the formation of a small light bridge. The evolution of active regions has been extensively studied for decades, and much progress has been achieved in understanding how flux is transported from deep in the convection zone to emerge at the solar surface in the form of sunspots. However, we still do not have a comprehensive picture of the detailed process of penumbral formation and decay, because observations of this precious moment in time are extremely rare.

Figure 1 shows the  $75 \times 75$  arcsec field of view (FOV) of IBIS (left) and depicts some moments during the transformation process based on speckle-reconstructed broad-band observations (right, from a to d in time,  $26 \times 26$  arcsec FOV). Interestingly, the penumbral segment was formed on the side of the pore that faces the opposite polarity (parallel to the line which connects the two parts of the bipolar region, about two o'clock in the figure).

Second, the chromospheric observations give strong evidence for large redshifts in both legs of the loop(s) that connect the two pores. Prelimi-

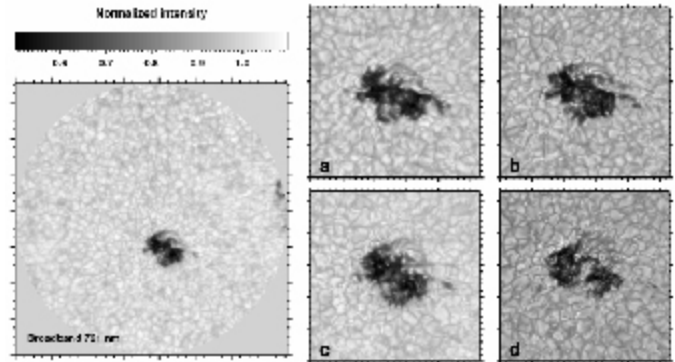

Figure 1: Left panel shows normalized broadband intensity at 721 nm (in units of the mean quiet Sun) showing the  $75 \times 75$  arcsec FOV observed with IBIS. Right panel shows individual speckle reconstructions showing four different time steps during the transformation process of a rudimentary penumbra into a penumbral segment.

nary line-of-sight (LOS) velocities confirmed this impression, indicating line-core Doppler shifts that correspond to velocities in the range of 10-20 km/s (see figure 2; the velocities in the Ca II Dopplergram have been clipped for better visibility of the fine structure in the flow field). Inspecting the Ca II 854.21 nm line profiles directly, we note the presence of strong line asymmetries in the form of redshifted line satellites.

In between the two redshifted legs we see indication of a blueshift. Considering the closeness to disk center, we interpret the measured LOS velocities as real upflows and downflows and speculate that we have captured the drainage of the rising magnetic loop associated with the bipolar region. Supersonic chromospheric downflows have been detected before, particularly in the footpoints of arch filament systems from H $\alpha$  observations (e.g., Bruzek, *Solar Physics*, 1969), but the combination of spectral and temporal coverage and excellent spatial resolution makes our observations very unique.

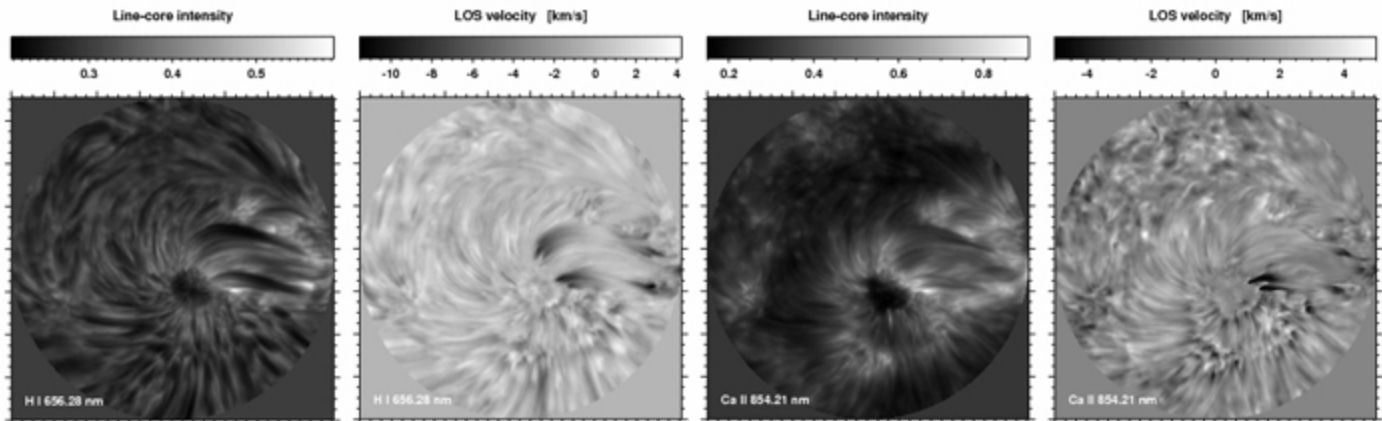

Figure 2. From left to right, line-core intensity and line-of-sight Dopplergram of H $\alpha$  and the Ca II 854.21 nm line, respectively. The FOV corresponds to  $75 \times 75$  arcsec.

# Carbon-enhanced Metal-poor Stars and the Chemical Evolution of the Early Galaxy

Simon Schuler

Very metal-poor stars ( $[Fe/H] \leq -2.0$ ) are relics of the earliest stellar populations, and the chemical abundances of their photospheres are signatures of the nucleosynthetic processes that occurred in the young Milky Way. Mapping the abundance patterns of these very metal-poor (VMP) stars provides stringent constraints for stellar nucleosynthesis and Galactic chemical evolution models.

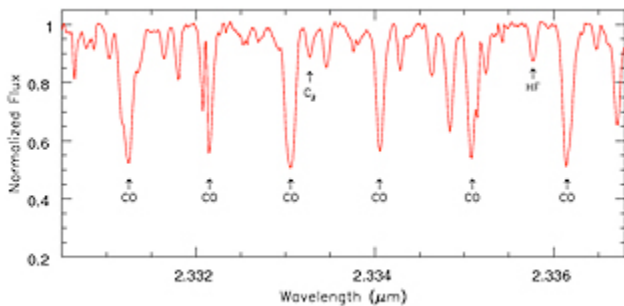

Figure 1: High-resolution near-IR Phoenix spectrum of the CEMP star HE 1305+0132 obtained with Gemini South. The spectrum is characterized by a resolution of  $R = 50,000$  and a per pixel signal-to-noise of 129. The HF (1-0) R9 line can be seen at 2.3358 microns. The prominent  $^{12}C^{16}O$  lines in the region are marked, as is a lone feature of the Phillips C\_2 system.

The number of identified VMP stars in the Galactic halo has increased significantly over the past decade or so, thanks to objective prism surveys such as the HK (Beers, Preston, & Shectman 1985, 1992) and Hamburg/ESO (HES; Wisotzki et al. 2000; Christlieb 2003) projects, and more recently, the Sloan Extension for Galactic Understanding and Exploration (SEGUE), a component of the first extension of the Sloan Digital Sky Survey (SDSS). Follow-up medium resolution spectroscopy—or in the case of SEGUE, the SDSS medium spectra themselves—have revealed that somewhere between 10-25% of VMP stars show surprisingly large enhancements of carbon ( $[C/Fe] \geq +1.0$ ). The fraction increases at lower metallicities, reaching 40% of stars at  $[Fe/H] \leq -3.5$  and 100% at  $[Fe/H] \leq -4.0$ , of which only three are currently known (e.g., Norris et al. 2007). The increased incidence of these so-called carbon-enhanced metal-poor (CEMP) stars at ever-decreasing metallicities suggests that the nucleosynthetic pathways leading to these interesting objects were highly efficient in the early Galaxy and that they played an important role in Galactic chemical evolution.

In addition to carbon, about 75% of CEMP stars are also enhanced in barium ( $[Ba/Fe] \geq +0.50$ ), a heavy element that is produced by the slow-neutron capture process (s-process) in the He-burning shells of thermally pulsating asymptotic giant branch (AGB) stars. Many of these stars, known as CEMP-s stars, do not have visible companions, but they have been identified through radial velocity measurements to be members of binary systems. Together, the s-process element enhancement and the binarity strongly suggest that CEMP-s stars have been contaminated by an evolved companion as it passed through its AGB phase.

Carbon, nitrogen, oxygen, and s-process element abundances derived from high-resolution spectra of CEMP-s stars provide important constraints for models of metal-poor AGB star nucleosynthesis. Stronger constraints can be applied to the models, however, by considering the abundance of an additional element,  $^{19}F$ .

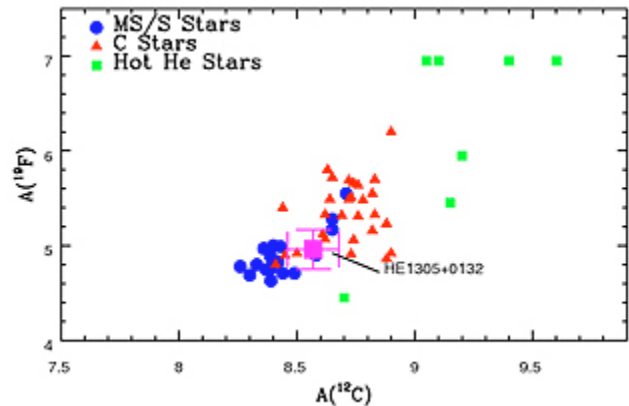

Figure 2: Logarithmic abundances of  $^{19}F$  plotted against those of  $^{12}C$ . The abundances of HE 1305+0132 are given by the large square with error bars and fall right on the trend defined by stars known to have been contaminated by AGB star companions. This figure is adapted from Schuler et al. (2007).

$^{19}F$  is the only stable isotope of fluorine, and one of its production sites is also the He-burning shell of an AGB star. The reaction chain responsible is  $^{14}N(\alpha, \gamma) ^{18}F(\beta^+) ^{8}O(\text{proton}, \alpha) ^{15}N(\alpha, \gamma) ^{19}F$ . The protons captured by  $^{18}O$  are provided by the  $^{14}N(\text{neutron}, \text{proton}) ^{14}C$  reaction, for which the required neutrons are provided by the  $^{13}C(\alpha, \text{neutron}) ^{16}O$  reaction.  $^{13}C$  and  $^{14}N$  are produced in the surrounding H-burning shell and subsequently mixed down into the He shell.

Our group is conducting an observational program using the high-resolution ( $R = \lambda/\Delta\lambda = 50,000$ ) near-IR Phoenix spectrograph on the Gemini South 8-meter telescope to derive  $^{19}F$  of CEMP stars.  $^{19}F$  abundances of late-type stars can only be derived from near-IR K-band spectral features arising from vibration-rotation transitions of the hydrogen fluoride (HF) molecule. For our program, we have specifically targeted the (1-0) R9 line at 2.3358 microns (see figure 1).

One of the first CEMP stars we observed, HE 1305+0132, showed a strong HF feature in its Phoenix spectrum that suggested a highly enhanced  $^{19}F$  abundance. Indeed, our abundance analysis revealed that it has a  $^{19}F$  abundance ( $A(^{19}F) = 4.96 \pm 0.21$  or  $[F/Fe] = 2.90$ ) that is almost three orders of magnitude greater than that of the Sun (Schuler et al., 2007)!

Figure 2 places the enhanced  $^{19}F$  abundance of HE 1305+0132 into context. In the figure, the  $A(^{19}F)$  abundances of three classes of stars are plotted against their  $A(^{12}C)$  abundances. The MS/S stars

*continued*

## Carbon-enhanced Metal-poor Stars continued

are intrinsic thermally pulsating AGB stars, the C stars are stars known to have been polluted by an AGB companion, and the hot He stars are essentially the exposed cores of former AGB stars. The abundances of HE 1305+0132 fall right on the A(19F)-A(12C) trend defined by the MS/S/C stars, pointing to an AGB nucleosynthesis origin of its 12C and 19F.

At the time of our analysis, no high-resolution abundance analysis had been carried out for HE 1305+0132, so it was not known beforehand if it fell into the CEMP-s star category, as the 19F abundance suggests. Our group has since obtained a high-resolution optical spectrum of this star using the High-Resolution Spectrograph (HRS) on the 9.2-meter effective aperture Hobby-Eberly Telescope (HET) with time granted through NOAO and the Telescope System Instrumentation Program (TSIP). Analysis of the HET/HRS spectrum is ongoing, but preliminary results suggest that the Ba abundance of HE 1305+0132 is near  $[Ba/Fe] = +1.0$ , solidly placing it in the CEMP-s category.

With Gemini South/Phoenix spectra of an additional 10 CEMP stars obtained in the 2007A and 2007B semesters, our analysis of 19F in CEMP stars continues. We have also recently been granted for this project 10.1 hours of time on the 8.2-meter ANTU (unit 1) telescope of the Very Large Telescope to use the new high-resolution near-IR

spectrograph CRIRES; our target list includes seven more CEMP stars. With the successful completion of the CRIRES program, our total sample will include 17 CEMP stars for which we will derive 19F abundances. These data will allow us to further constrain low-metallicity AGB star nucleosynthesis and the chemical histories of CEMP stars. Making progress in both of these areas will greatly improve our understanding of early Galactic chemical evolution.

I gratefully acknowledge my collaborators involved with this project: Katia Cunha and Verne V. Smith at NOAO, and Thirupathi Sivarani, Timothy C. Beers, and Young Sun Lee at Michigan State University/Joint Institute for Nuclear Astrophysics. 

### REFERENCES

- Beers T., Preston R., & Shectman, S. 1985, *A J*, 90, 2089  
 Beers, T., Preston R., & Shectman, S. 1992, *AJ*, 103, 1987  
 Christlieb, N. 2003, *The Cosmic Circuit of Matter*, ed. R. Scheilicke (Wiley), 191  
 Norris, J. et al., 2007, *ApJ*, 670, 774  
 Schuler, S., Cunha, K., Smith, V., Sivarani, T., Beers, T., and Lee, Y. S. 2007, *ApJ*, 667, L81  
 Wisotzki, L., Christlieb, N., Bade, N., Beckmann, V., Koehler, T., Vanelle, C., & Reimers, D., 2000, *A&A*, 358, 77

# Do Solar Subsurface Vorticity Measurements Improve Flare Forecasting?

*Rudi Komm, Frank Hill (NSO) & Ryan Ferguson (REU/Michigan State University)*

**R**egions of strong magnetic fields (active regions) are the locations of strong eruptive phenomena such as flares and coronal mass ejections, which can disrupt technology on Earth. Highly twisted magnetic fields are very probably responsible for these phenomena. These fields extend from below the surface through the solar atmosphere into the interplanetary medium (heliosphere). Flows below the solar surface are accessible with the techniques of local helioseismology, which are currently the only way to measure anything related to active regions below the solar surface.

Subsurface flows below active regions are rather complex (see figure 1, next page). Besides showing in- or outflows varying with depth, the subsurface flows below active regions are highly twisted (Komm, 2007). This twist can be measured by the vorticity vector (curl of velocity) which corresponds to changing orientation in space of fluid, and is thus a quantity associated with mixing. The zonal (east-west) and the meridional (north-south) component of the vorticity vector show a dipolar pattern of opposite signed values below strong active regions (see figure 1).

This pattern is analogous to two smoke rings stacked on top of each other and coincides with locations of flare activity in active regions. In a previous study (Mason et al., 2006), we defined a quantity to capture this pattern in a single value and found that flare activity is in-

trinsically linked to subsurface phenomena on timescales and spatial scales comparable to the lifetime and size of active regions. The question remains whether the measured vorticity of subsurface flows can help to improve the forecasting of flare activity of active regions.

We have begun to address this question using the data set from the previous study, which Ryan Ferguson (a NSO 2008 Research Experiences for Undergraduates student from Michigan State University) extended to include data through 2007. The data set is the largest of its kind and consists of 1,009 active regions and their subsurface flow measurements derived from Global Oscillation Network Group (GONG) data. The data set also includes the magnetic flux of each active region from NSO/Kitt Peak and Synoptic Optical Long-term Investigations of the Sun synoptic maps, and the corresponding X-ray flare information from the Geostationary Operational Environmental Satellite (GOES). We determine solar subsurface flows with a ring-diagram analysis and remove the average differential rotation and the average meridional flow to focus on the variation of the flows associated with active regions.

Some of the results are presented here. The left panel of figure 2 shows the total flare intensity of active regions, which is a proxy of their total X-ray flare activity over an active region's lifetime. A flare-prolific active region is clearly characterized by large magnetic flux

*continued*

Do Solar Subsurface Vorticity Measurements Improve Flare Forecasting? continued

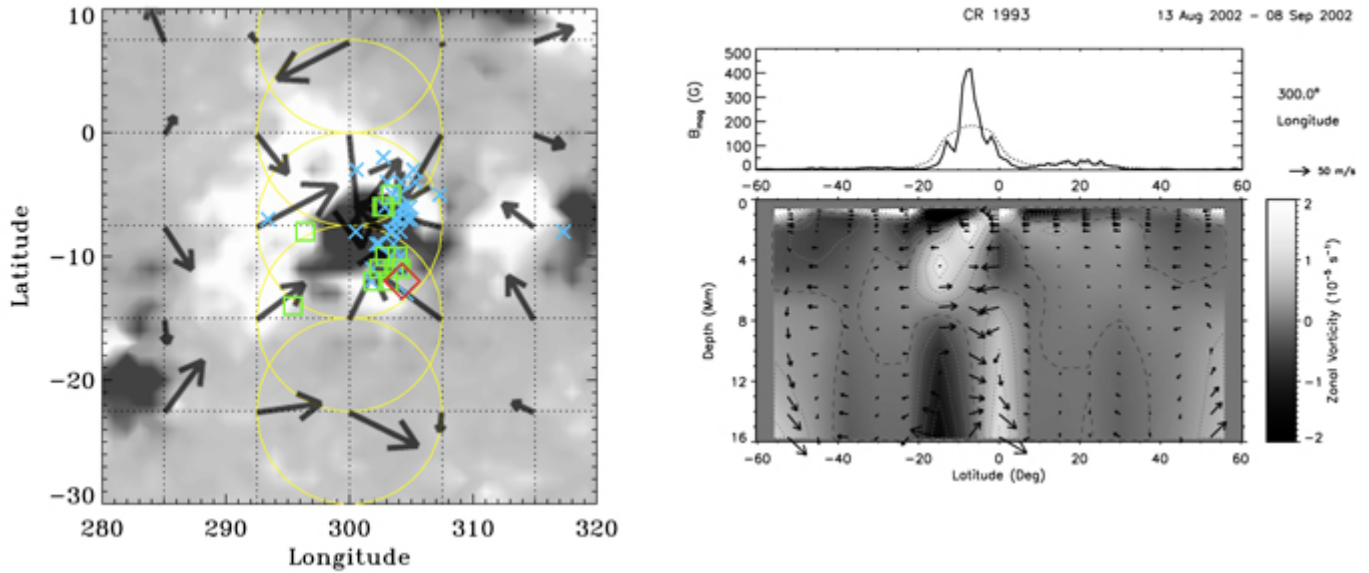

Figure 1: The left panel shows the surface magnetic field of active region 10,069. Flare locations are superposed with cross symbols for C-class flares, squares for M-class flares, and a diamond symbol for an X-class flare. The subsurface velocities at a depth of 7 Mm are superposed as arrows corresponding to values of about  $30 \text{ m s}^{-1}$ . Open circles indicate dense-pack patches at  $300^\circ$  longitude. All flares are located within the dense-pack patch located at  $-7.5^\circ$  latitude and  $300^\circ$  longitude. The right panel shows a grey-scale slice of the zonal vorticity component at the same longitude with meridional flows superposed as arrows and a line drawing of the unsigned magnetic flux on top. The location of active region 10,069 coincides with large vorticity values; the flows below the active region are highly twisted. The dipolar vorticity pattern is typical of strong active regions that produce many flares.

and large vorticity values. A large magnetic flux is not sufficient to determine whether a given active region will be flare-prolific or not. Even at high flux values, there are active regions with low vorticity that do not produce energetic flares. The middle panel shows the same for the M-class of X-ray flares. (Of the 1,009 active regions analyzed, 425 regions produced at least a C-class flare, while 130 regions produced at least an M-class flare and only 19 regions produced an X-class flare.) It is clear that the strongest flares occur when both the flux and the vorticity values are high.

From this result, we can deduce the probability that an active region within a certain range of vorticity and magnetic flux produces an M-class flare, as shown in the right panel. This probability is 81% for

a region in the bin with the largest flux and vorticity values compared to an overall probability of 44% for the four bins with the largest magnetic flux or only 13% for the whole data set. It is clearly beneficial to include the vorticity information in this case. We find similar results for C- and X-class flares.

The inclusion of subsurface vorticity improves the ability to distinguish between flaring and non-flaring active regions compared to using magnetic flux alone. The results presented here characterize the average behavior of active regions during their disk passage and not their evolution on much shorter time scales. We expect to present results on the temporal variation of subsurface flows of active regions related to their flare activity in the near future. **N**

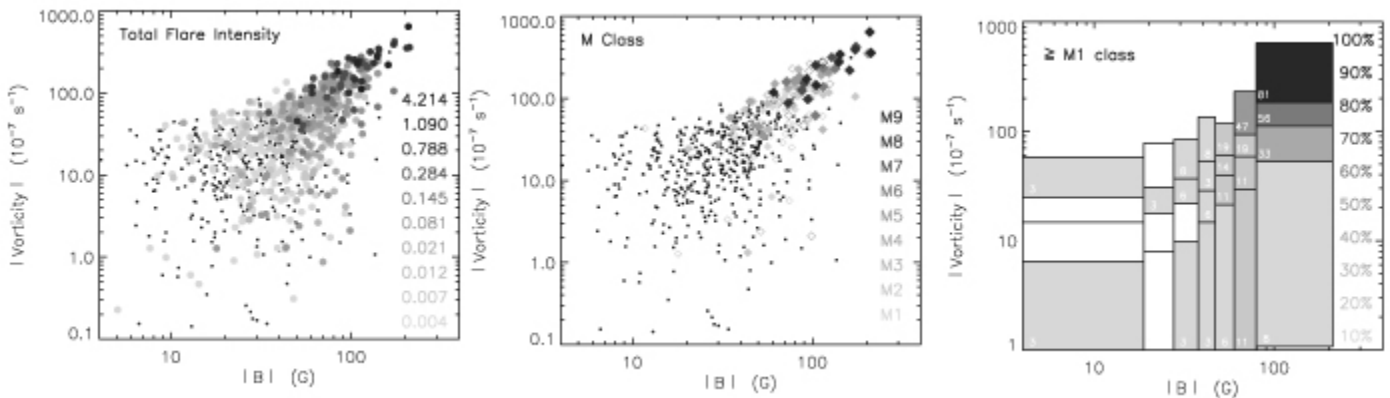

Figure 2: The left panel shows the surface magnetic field  $B$  and vorticity of 1,009 active regions. Grey circles indicate the flare intensity levels summed over all flares in each region. (Black crosses indicate non-flaring active regions). The flares occur mainly when the active regions have high values of both  $B$  and vorticity. The middle panel shows a similar plot but for M-class flares only. Filled (open) diamond symbols indicate active regions that produced multiple (only one) M-class flares. The right panel divides up the active regions so that each box contains an equal number of points. The number in the bins are the percentage of active regions with at least one flare with an M-class or greater magnitude. Grey scales indicate the probability levels in steps of 10%, white is zero. It is clear that the strongest flares occur when both  $B$  and vorticity are high.





## First Thoughts and Early Priorities

David Silva

“Engaging the community” is always a hot topic at NOAO, and it is foremost in the mind of the director of NOAO. Making this engagement a two-way dialog is always a challenge. It is relatively easy to push out information: it is much harder to gather a representative opinion, and harder still to synthesize a diverse range of opinion into a coherent and robust program.

Gathering and synthesizing suggestions and opinions was a high priority for Todd Boroson, our recent interim director, and it remains a high priority for me. So, to whom do we talk?

First come our “owners”: the NSF, the AURA Board, and the AURA member representatives at large. Then come our standing committees: the Observatory Council (appointed by the AURA Board), the Users Committee (appointed by NOAO), the US Gemini Science Advisory Committee (also appointed by NOAO), the Program Review Panel (appointed by the NSF), and the Visiting Committee (appointed by the AURA corporate office). We meet with all these groups at least once per year. The AURA Board and Observatory Council meet three times per year. We talk with our NSF Program Manager (currently Tom Barnes) at least weekly.

For specific topics, we form and interact with ad hoc finite term committees, such as ReSTAR and ALTAIR (see articles elsewhere in this *Newsletter*). Major partnerships and projects create other community-based committees and boards (e.g., the WIYN Observatory, SOAR Observatory, Dark Energy Survey, the Large Synoptic Survey Telescope project). And of course we make NOAO staff scientists available for conversation at all American Astronomical Society (AAS) meetings, especially the winter meetings where we hold an annual town hall meeting.

A large number and broad range of US astronomers serve on these various boards, standing committees, and ad hoc committees or come to the town hall meetings. We are very grateful for their service, strategic guidance, and suggestions for near-term improvement.

In the future, I see an ongoing series of one-day meetings across the country to present our view of building the system and have a conversation with the audience. This will not replace the winter AAS town hall meeting, but augment it. Such meetings have the advantage of being more or less time constrained and more free-form, while involving less travel for participants. I'll write more about this meet-

ing series as plans for it mature. If you are interested in hosting one of these meetings, please contact Laurie Phillips ([lphillips@noao.edu](mailto:lphillips@noao.edu)).

I do not have space here to discuss our Web presence, but we know that it can be improved, in both form and content. The new NOAO e-newsletter, *Currents*, is a good step forward and I hope you read it. We can and will do more.

Obviously, NOAO senior staff members go to a lot of meetings where we discuss the key issues facing the national observatory and shape our efforts to provide the best possible scientific capabilities that we can afford. But we like talking to all of you more! It is the only way to be sure we are really helping you achieve your science aspirations and supporting the greatest adventure of our time—the scientific exploration of the Universe.

Ad astra and clear skies!

### Director's Office Transitions

I began a five-year term as NOAO director in early July. After serving as interim director for 18 months, Todd Boroson has returned to the deputy director role for three months to help me with my transition and to work important projects such as ReSTAR implementation planning. After September, Todd will be on science sabbatical leave until mid 2009. Many thanks to Todd for stepping into the directorship at such a difficult moment and for providing such a steady hand at the helm. (And you're welcome for all the fish!)

Laurie Phillips has become the full-time administrative assistant for the NOAO Director's Office. Many of you already know Laurie from her recent assignments in the New Initiatives and Giant Segmented Mirror Telescope program offices, and her past role in the AURA corporate office. Welcome, Laurie.

Jessica Moy, Barbara Fraps, Mia Hartman, Beth Moore and Jane Price complete the Director's Office team. In a collaborative manner, these people perform crucial administrative roles in major report generation and management, telescope time allocation, science staff support, and committee meeting support. In addition, Jessica is the NOAO North librarian, Barbara works half time for the Data Products Program, and Beth works half time for the System Instrumentation Program.

*continued*



*First Thoughts and Early Priorities continued*

**Infrastructure Improvement Funding from NSF**

As I gazed out across the beautiful Sonoran Desert from the Mayall 4-meter telescope visitor gallery recently, I was inspired to ask, "Gosh, when is the last time these windows were washed?"

Okay, this is not the most serious problem facing NOAO. But it does illustrate the maintenance backlog NOAO has developed at all our aging facilities. In the aftermath of the Senior Review, we have re-emphasized infrastructure maintenance at all our sites.

To that end, I am pleased to report that the NSF recently awarded an extra \$300,000 to NOAO for infrastructure maintenance. This money will go mainly for critical projects that might forestall the loss of 4-meter observing time or performance quality, such as the floor-cooling system and main shutter emergency brakes at the Mayall, and a new instrument clean room at the Blanco. We've also put aside a small amount of money for new control room furniture and appliances.

And hopefully, we can get those Mayall windows washed soon. 

## The GSMT Chicago Workshop – First Steps Toward a National Design Reference Mission

Jay Elias

A very successful workshop titled "Science with Giant Telescopes" was held in Chicago in June. The workshop was intended to initiate community-wide discussions of the scientific opportunities potentially available through public participation in one (or more) of the Extremely Large Telescope (ELT) projects now underway. The workshop was sponsored by NOAO and its Giant Segmented Mirror Telescope Science Working Group (GSMT SWG).

The workshop was attended by close to 100 scientists, most of whom are not directly related to any of the three existing ELT projects. Presentations included summaries of project status from the Thirty Meter Telescope (TMT) and Giant Magellan Telescope (GMT), and from the European ELT project. Science-use cases were presented to illustrate the range and scope of programs that could be carried out on such telescopes, and a series of panel discussions described the issues and opportunities raised by operation of these potential new facilities.

The presentation materials are available online at [www.gsmt.noao.edu/swgt-presentations.php](http://www.gsmt.noao.edu/swgt-presentations.php). In addition, the participants who presented science-use cases were asked to produce a written document elaborating on one or more of the cases outlined in their workshop presentations, and these are also available on the Web site.

These use cases are intended to serve as indicators of ELT science areas interesting to the US community at large. Thus, they serve to reinforce and extend science case documents previously developed by the GSMT SWG and the two US-led projects. The comprehensive ELT science case that emerges will be the backbone for the development of a national Design Reference Mission (DRM), which the National Science Foundation has requested from NOAO. This DRM must be completed and prepared for presentation in time for the next round of decadal survey discussions in 2009-2010.

The next stage in broadening the national ELT science case will be a community-wide solicitation for additional use cases, probably in the form of a mock proposal process similar to that used for submission of NOAO observing proposals. Further details will be announced in future editions of the *NOAO/NSO Newsletter* and the electronic NOAO newsletter *Currents*.



**SCIENCE WITH GIANT TELESCOPES:**  
Public Participation in TMT and GMT

**JUNE 15-18  
2008**  
INTERCONTINENTAL HOTEL  
CHICAGO, ILLINOIS

The Workshop will be the next major step in developing the private-public partnership envisioned in the 2000 Decadal Survey; its proceedings will be a supporting document for presentation—on behalf of the entire US astronomical community—to the new Decadal Survey. For further details see <http://www.gsmt.noao.edu/swgt.php>

**Sponsored By**  
GSMT Science Working Group  
National Optical Astronomy Observatories  
Great Magellan Telescope  
Thirty Meter Telescope

**Scientific Organizing Committee**  
Alan Dressler, Carnegie Observatories, Chair  
Elizabeth Barker, University of California, Irvine  
Todd Burrows, National Optical Astronomy Observatories  
Christopher Chesney, University of North Carolina

Johnnie Dabrowski, University of Washington  
Stephen Elliott, University of Florida  
Steve Martinelli, University of Virginia  
Dimitris Moutou, Yale University

# LSST Mirror Unveiled

*Victor Krabbendam*

The Large Synoptic Survey Telescope (LSST) project achieved another significant milestone on 23 July 2008, when the casting furnace at the University of Arizona Steward Observatory Mirror Lab was opened to reveal a perfect casting of the LSST primary mirror.

The top lid of the furnace was removed to expose the freshly cast mirror after the 112-day heating and cooling process. In March, 26 tons of glass was loaded into the furnace and heated to 1165 C while it rotated at 6.7 revolutions per minute so the glass could flow through the mold and form the base parabolic shape. Since then, the furnace has

let the glass slowly cool back to room temperature. This three-month process has gone very smoothly.

This milestone is a significant step toward building a unique mirror that has both the 8.4-meter diameter primary mirror surface and the 5-meter diameter tertiary surface of the LSST in the same optic. After the mirror is removed from the furnace and the refractory material is cleaned out, grinding and polishing can begin. The grinding effort will include removing nearly five tons of glass that is now pooled above the tertiary mirror as part of the casting. The fully polished mirror is scheduled for delivery in January 2012.

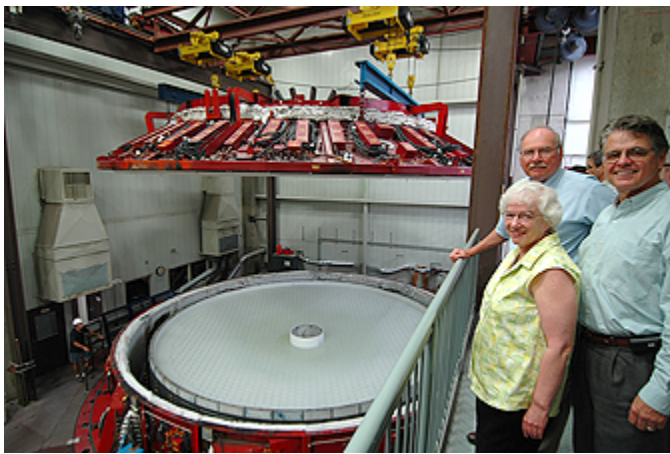

John Schaefer (back), Sidney Wolff, and Don Sweeney (front) observe the opening of the furnace for the debut of the LSST mirror. Photo: V. Krabbendam

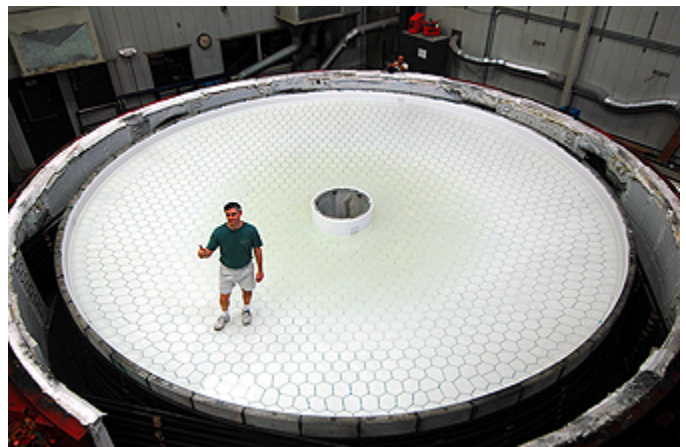

Randy Lutz, casting manager at the Steward Mirror Lab, is very pleased following his initial inspection of the LSST mirror casting. Photo: V. Krabbendam

## ALTAIR Committee and Survey

*Joan Najita*

As part of its response to the NSF Senior Review, NOAO has formed a community-based committee called Access to Large Telescopes for Astronomical Instruction and Research (ALTAIR), which is charged with developing a prioritized, quantitative, science-justified list of capabilities for 6.5- to 10-meter telescopes in the US system, including Gemini. The committee has been asked to focus on what the US community desires in terms of capabilities and access to telescopes in this aperture range both now and over the next 10 years. Details on the charge and membership of the committee are available at the ALTAIR committee Web site ([www.noao.edu/cgi-bin/altair/survey.pl](http://www.noao.edu/cgi-bin/altair/survey.pl)).

The goals of the ALTAIR study are similar to those of the recent ReSTAR committee study, which studied the needs of the US community for 2- to 4-meter telescopes. The reports of both committees will be used by NOAO to meet the Senior Review directive that community access to facilities remains scientifically balanced over all apertures.

Following the approach taken by ReSTAR, the ALTAIR committee is currently soliciting community input by means of an online survey. The survey probes your current and/or anticipated future use of 6.5- to 10-meter facilities, including aspects such as required instrumentation, observing modes, observ-

ing time, and other resources. The first part of the survey, which is designed to provide a snapshot of your needs and priorities, requires only about 10 minutes to complete. In the second part of the survey, you are invited to describe in greater detail the resources needed to achieve your future science goals. You are also invited to express your views on the allocation of US federal funding for 6.5- to 10-meter class telescopes.

Please respond to the survey to make your needs and views known. Your input will guide the evolution of the NOAO program and the investment of NSF resources.

*continued*

*ALTAIR Committee and Survey continued*

Survey input received by mid August will be discussed in early September at the next meeting of the ALTAIR committee. However, the survey Web site will remain open

into the fall, so you still have the opportunity to respond to the survey if you have not already done so. A high response rate will be important in demonstrating the demand

for resources at the 6.5- to 10-meter aperture class. The survey results will be reported here and in future issues of the NOAO electronic newsletter *Currents*. 

## Building the ReSTAR System

*Todd Boroson*

Last year, the Renewing Small Telescopes for Astronomical Research (ReSTAR) committee surveyed the US community and assembled a set of recommendations and priorities for capabilities needed on small and mid-sized telescopes. Their report can be accessed at [www.noao.edu/system/restar/files/ReSTAR\\_final\\_14jan08.pdf](http://www.noao.edu/system/restar/files/ReSTAR_final_14jan08.pdf).

As a response to this report, NOAO initiated two activities: (1) an effort to modernize the mountaintop and telescope infrastructure and restore community access at our existing facilities, Kitt Peak National Observatory and Cerro Tololo Inter-American Observatory, and (2) development of a program to provide new or upgraded instruments and additional access on telescopes in this aperture range, including some owned and operated by non-federal organizations. This article reports on the status of that second activity.

Our adopted approach to this activity includes four components. First, the program will address the most pressing needs for modern, high-performance instrumentation, emphasizing optical and infrared spectroscopy. We will identify already designed and developed instruments that have demonstrated the needed capabilities, and we will partner with community groups to adapt them and build them. Much of the work will be done by instrumentation groups throughout the community. While the initial partnerships will be determined by the existence of good instrument designs and willing and capable



teams, there will be future opportunities for other groups and other instruments.

The second component will be new partnerships with existing facilities to provide new public access. We are discussing opportunities with several observatories that have or are developing state-of-the-art instrumentation, and have operations and support models that are consistent with broad community access. We will try to structure these as long-term commitments (3-5 years minimum) so that both the users and the facilities can expect some continuity.

The third component will be an effort to broadly improve the supporting infrastructure, including things like telescope control systems, calibration systems, and equipment for handling and maintaining modern instruments. Whether these improvements focus on the federal facilities or can be applied to non-federal facilities will depend on whether the NOAO core budget is close to the level promised or not. This sort of infrastructure renewal was built into the plan for the higher level of funding that we were told to expect, but this level has—so far—not materialized. If the ReSTAR-funded improvements are

used for non-federal facilities, this will translate into more new access for the community.

Finally, we will undertake studies to understand what the next phase of ReSTAR implementation should be. There are a number of areas, including time-domain research, adaptive optics, and optical interferometry, that are clearly important but not at the top of the priority list. How should the program evolve to address those needs?

Community input and guidance will be requested and utilized throughout the process. The ReSTAR recommendations and priorities come from a community survey, and, as the details of the plan are developed, they will be reviewed by community-based committees, including the ReSTAR committee and the NOAO Users Committee. We will publicize them for community discussion. We expect to have a white paper that describes the plan and the options we have chosen available through the NOAO Web site in the next few weeks. Please watch the Web site and our *Currents* electronic newsletter for more information and a chance to comment.



## Gemini Classical and Queue Observing Opportunities for Semester 2009A

Verne V. Smith

Semester 2009A runs from 1 February 2009 to 31 July 2009, and the NOAO Gemini Science Center (NGSC) encourages the US community to propose for Gemini observing time during 2009A. The Gemini Observatory provides unique opportunities in observational and operational capabilities, such as the ability to support both classically and queue scheduled programs. In an effort to increase interactions between US users and the Gemini staff, as well as observing directly with the telescopes and instruments, **NOAO strongly encourages US proposers to consider classical programs, which can be as short as one night, on the Gemini telescopes.**

US Gemini observing proposals are submitted to and evaluated by the NOAO Time Allocation Committee (TAC). The formal Gemini Call for Proposals for 2009A will be released in late August 2008 (before the mailing of this *Newsletter* issue), with a US proposal deadline of Tuesday, 30 September 2008. As this article is prepared well before the release of the Call for Proposals, the following list of instruments and capabilities are only our expectations of what will be offered in semester 2009A. Please watch the NGSC Web page ([www.noao.edu/usgp](http://www.noao.edu/usgp)) for the Gemini Call for Proposals, which will list clearly and in detail the instruments and capabilities that will be offered.

NGSC anticipates the following instruments and modes on Gemini telescopes in 2009A:

### Gemini North:

- Near-infrared Integral Field Spectrometer (NIFS).
- Near Infra-Red Imager (NIRI) and spectrograph with both imaging and grism spectroscopy modes.
- Altair adaptive optics (AO) system in Natural Guide Star (NGS) mode, as well as in Laser Guide Star (LGS) mode. Altair can be used with NIRI imaging and spectroscopy and with NIFS IFU imaging and spectroscopy, as well as NIFS IFU spectral coronagraphy.
- Michelle, mid-infrared (7-26 microns) imager and spectrometer, which includes an imaging polarimetry mode.
- Gemini Multi-Object Spectrograph (GMOS-North) and imager. Science modes are multi-object spectroscopy (MOS), long-slit spectroscopy, integral-field unit (IFU) spectroscopy and imaging. Nod-and-shuffle mode is also available.
- All of the above instruments and modes are offered for both queue and classical observing, except for LGS which is available as queue only. **It is important to note that classical runs are now offered to programs that are one night or longer, and which consist of integer nights.** The offer of one-night classical runs opens up the possibility of many more Gemini programs being eligible for classical observing, if the program Principle Investigators (PIs) want to use this mode.
- Details on use of the Laser Guide Star (LGS) system can be found at [www.gemini.edu/sciops/ObsProcess/ObsProcIndex.html](http://www.gemini.edu/sciops/ObsProcess/ObsProcIndex.html), but a few

points are emphasized here. Target elevations must be >40 degrees and proposers must request good weather conditions (Cloud Cover=50 percent, or better, and Image Quality=70 percent, or better, in the parlance of Gemini observing conditions). Proposals should specify "laser guide star" in the resources section of the observing proposal. Because of the need for good weather, LGS programs must be ranked in Bands 1 or 2 to be scheduled on the telescope.

- Time trades will allow community access to the high-resolution optical spectrograph, HIRES, on Keck, as well as to the Suprime-Cam wide-field imager and the infrared imager and spectrograph (MOIRCS) on Subaru.
- Gemini Near-Infrared Spectrograph (GNIRS) commissioning during 2009A. The repair and refurbishment of GNIRS continues in Hilo and it is planned that sometime during 2009A the spectrograph will be deployed on Gemini North to undergo commissioning on this telescope. GNIRS will not be available as a general user instrument in the 2009A Call for Proposals, however, its commissioning on Gemini North may affect the telescope schedule.

### Gemini South:

- Thermal-Region Camera Spectrograph (T-ReCS) mid-infrared (7-26 microns) imager and spectrograph.
- Gemini Multi-Object Spectrograph (GMOS-South) and imager. Science modes are multi-object spectroscopy (MOS), long-slit spectroscopy, integral-field unit (IFU) spectroscopy and imaging. Nod-and-shuffle mode is also available.
- Phoenix, the NOAO high-resolution infrared spectrograph (1-5 microns) is expected to be available during 2009A, although the likely appearance of both FLAMINGOS-2 and the multi-conjugate adaptive optics system CANOPUS on the telescope may impact the scheduling of Phoenix. Users should keep an eye on either the Gemini Web site ([www.gemini.edu](http://www.gemini.edu)) or the NGSC site ([www.noao.edu/usgp/](http://www.noao.edu/usgp/)) for the most up-to-date information about Phoenix.
- Near-Infrared Coronagraphic Imager (NICI). With the planned beginning of the science campaign in semester 2008B, NICI is expected to be available for general user proposals in 2009A. NICI will be scheduled as a shared-risk instrument and can only be used in on-axis coronagraphic imaging mode.
- All modes for GMOS-South, T-ReCS, Phoenix, and NICI are offered for both queue and classical observing. **As with Gemini North, classical runs are now offered to programs with a length of at least one or more of integer nights.**

Detailed information on all of the above instruments and their respective capabilities is available at [www.gemini.edu/sciops/instruments/instrumentIndex.html](http://www.gemini.edu/sciops/instruments/instrumentIndex.html).

*continued*

## *Gemini Observing Opportunities for Semester 2009A continued*

The percentage of telescope time devoted to science program observations in 2009A is expected to be greater than 80 percent at Gemini North and greater than 70 percent at Gemini South.

We remind the US community that Gemini proposals can be submitted jointly with collaborators from other Gemini partners. An observing team requests time from each relevant partner. Multi-partner proposals are encouraged because they access a large fraction of the available Gemini time, thus enabling larger programs that are likely to have substantial scientific impact. Please note that all multi-partner proposals must be submitted using the Gemini Phase I Tool (PIT).

Note that queue-proposers have the option to fill in a so-called "Band 3" box, in which they can optimize their program execution if it is scheduled on the telescope in Band 3. Historically, it has been found that somewhat smaller than average queue programs have a higher probability of completion if they are in Band 3, as well as if they use weather conditions whose occurrences are more probable. Users might want to think about this option when they are preparing their proposals.

Efficient operation of the Gemini queue requires that it be populated with programs that can effectively use the full range of observing conditions. Gemini proposers and users have become increasingly experienced at specifying the conditions required to carry out their

observations using the online Gemini Integration Time Calculators (ITCs) for each instrument. NGSC reminds you that a program has a higher probability of being awarded time and being executed if ideal observing conditions are not requested. The two conditions that are in greatest demand are excellent image quality and no cloud cover. We understand the natural high demand for these excellent conditions, but wish to remind proposers that programs that make use of less than ideal conditions are also needed for the queue.

There is continuing need for proposals that can be run under the poorest conditions. To help fully populate the queue, a category for poor weather proposals has been established. Poor weather programs may be submitted for any facility instrument: for these proposals, neither the PI nor the partner country will be charged for any time used. For additional information, please see the link at: [www.gemini.edu/sciops/ObsProcess/ObsProcCfP\\_background.html](http://www.gemini.edu/sciops/ObsProcess/ObsProcCfP_background.html)

NOAO accepts Gemini proposals via either the standard NOAO Web proposal form or the Gemini PIT software. We note to proposers who plan to use the PIT that NOAO offers a tool that allows one to view how their PIT proposal will print out for the NOAO TAC (please see [www.noao.edu/noaoprop/help/pit.html](http://www.noao.edu/noaoprop/help/pit.html)).

Feel free to contact me ([vsmith@noao.edu](mailto:vsmith@noao.edu)) if you have any questions about proposing for US Gemini observing time. ☺

# Suitable 2009A Gemini Queue Programs May Be Offered Classical Time

*Verne V. Smith, Todd Boroson & David Silva*

The two Gemini telescopes provide several unique and powerful capabilities to US observers, including full-sky coverage with 8-meter telescopes, excellent mid-infrared sensitivity, and the ability to support flexible queue-scheduled programs (including targets of opportunity or synoptic observations) at any level of available science observing time. Although Gemini can support 100 percent queue observing, it was not envisioned that the observing time should in fact be all queue; Gemini can also be used in classical observing mode. Historically, about 10-20 percent of the US time on Gemini has gone to classically scheduled programs.

The evolution to largely queue-scheduled telescopes has placed Gemini in a unique position within the ground-based optical/infrared "system" of telescopes available to US observers, in that it has led to a rather small number of users having actually traveled to the telescopes, observed with them directly, or even visited the Gemini offices. Direct usage of the telescopes and instruments, as well as close interactions between the users and the Gemini staff astronomers, is mutually beneficial to the user community and Gemini staff. Because of such benefits, NOAO encourages US users to consider applying for classical observing on the Gemini telescopes if their proposed programs are suitable. The only restriction on classical requests is that they cover integer nights with a one-night minimum.

In addition to interaction with the staff and direct usage of the telescopes, classical observing has other advantages for certain programs. It allows modifications of the program in real time and the ability to choose the sequence of the observations, and can result in increased efficiency. The principle investigator (PI) can verify what is being done, for instance with critical positioning, when he or she is in the control room.

In an effort to increase the fraction of classical programs within the US share of time, NOAO may identify a subset of Gemini programs submitted as queue mode that would benefit from classical scheduling. The PIs of these programs would be contacted about the possibility of switching to classical mode. If they accepted classical, the PI plus one other observer if needed would have all of their travel expenses paid by NOAO. These visits to the telescopes and offices would be of benefit to both the US users and the Gemini staff and will help all of us in planning for the long-range scientific and operational goals for Gemini.

Comments or questions about this plan can be addressed to Verne Smith, Director of the NOAO Gemini Science Center, via email ([vsmith@noao.edu](mailto:vsmith@noao.edu)) or telephone (520-318-8453).

# The Personal Contact Option for the Gemini HelpDesk

*Verne V. Smith & Ken Hinkle*

The NOAO Gemini Science Center (NGSC) would like to announce an additional option as part of the Gemini HelpDesk system for US users. The current Gemini HelpDesk is a Web-based interface ([www.gemini.edu/sciops/helpdesk/](http://www.gemini.edu/sciops/helpdesk/)) through which you can send questions or make requests for information about Gemini to NGSC. Although using the Web is a quick and easy way to submit questions, we are now adding the option of contacting a person at NGSC directly, if this is your preference.

Astronomers at US institutions may now either use the Gemini HelpDesk or email questions and requests directly to [gemini-help@noao.edu](mailto:gemini-help@noao.edu).

*edu*. Emails sent to this address will be handled initially by Ken Hinkle, Sally Adams, and Verne Smith, who will work with users to answer questions. Ken can also be contacted by phone at 520-318-8298. In some cases, your questions may be answered directly; in other cases, they may be forwarded to another NGSC astronomer or directed to the Web-based HelpDesk, if that is the best option. We can also help you enter your request into the HelpDesk system.

This new option is not a substitute for the current HelpDesk, but rather an addition that may be useful for certain types of questions or for those users who feel inclined to deal directly with NGSC staff.

# The Joint Subaru/Gemini Conference "Cosmology Near and Far: Science with WFMOS"

*Katia Cunha & Arjun Dey*

Members of the Gemini and Subaru astronomical communities met in May to discuss a vast array of science cases that would be enabled by the future deployment of two new instruments on the Subaru telescope: the Gemini Wide-Field Multi-object Spectrograph (WFMOS) and the HyperSuprime Camera (HSC). The meeting, titled "Cosmology Near and Far: Science with WFMOS" ([www.naoj.org/Information/News/wfmos2008/](http://www.naoj.org/Information/News/wfmos2008/)) was held in Waikoloa, Hawaii, and was hosted jointly by the Subaru and Gemini observatories.

This gathering provided a venue for the Gemini and Subaru communities to discuss not only key programs such as Galactic Archaeology and Dark Energy Survey Science, but also smaller principle investigator-led research projects enabled by WFMOS that cut across a wide array of science topics. In a panel discussion session held at the end of the meeting, Subaru and Gemini representatives discussed the impact on their respective user communities in undertaking such large and

expensive projects, but it was acknowledged that the scientific potential of this relatively unique and highly-multiplexed capability was enormous.

The conceptual design studies for WFMOS are currently underway (see the WFMOS update article in this section), and 2009 represents the decision point for both Subaru and Gemini on whether or not to proceed with WFMOS. The observatories are expanding the cross-section between their user communities by jointly organizing the next Gemini Science Meeting to be held in Kyoto, Japan in May 2009 ([www.gemini.edu/node/10981](http://www.gemini.edu/node/10981)).

All the presentations made at the Waikoloa meeting may be found on the Web ([www.naoj.org/Information/News/wfmos2008/](http://www.naoj.org/Information/News/wfmos2008/)). This meeting was co-sponsored by the US National Optical Astronomy Observatory, the Japan Society for the Promotion of Science, the UK Science and Technology Facilities Council, and Astronomy Australia Limited.



Participants at the joint Subaru/Gemini WFMOS Science conference in Waikoloa, Hawaii, May 2008.

# The Gemini/Subaru Wide-field Fiber Multi-Object Spectrograph (WFMOS): An Update

Arjun Dey, Katia Cunha & Verne V. Smith

The Wide-Field Multi-Object Spectrograph (WFMOS), which will be deployed on the Subaru telescope as a collaborative project of the Gemini and Subaru communities, is being designed to provide an unmatched combination of multi-object spectroscopy and field of view. Capable of simultaneously targeting over 3,000 objects in a single 1.5-degree field, WFMOS will enable astrophysical investigations of unprecedented scale. Its initial key scientific goals are to provide stringent constraints on the redshift evolution of the equation of state of dark energy, unravel the formation history of our own Galaxy, and undertake the high-redshift equivalent of the Sloan Digital Sky Survey galaxy surveys. In addition to these large survey programs, a wide variety of smaller, principle investigator (PI)-driven projects will be possible with the unique capabilities provided by WFMOS.

In March 2005, an international team led by the Anglo-Australian Observatory (and including NOAO; Johns Hopkins, Oxford, Durham, and Portsmouth universities; and the Canadian Astronomy Data Center) completed a feasibility study of the WFMOS for both the Gemini and Subaru Observatories ([www.gemini.edu/files/docman/science/aspen/WFMOS\\_feasibility\\_report\\_public.pdf](http://www.gemini.edu/files/docman/science/aspen/WFMOS_feasibility_report_public.pdf)). This study was favorably reviewed by an independent committee appointed by the Gemini Observatory, and by the Gemini Science Committee and the Gemini Board. The committee report concluded that “WFMOS offers the most transformative science opportunities” of any of the future Gemini instruments. In August 2005, the Gemini Board recommended that Gemini Observatory proceed with a conceptual design study of WFMOS ([www.gemini.edu/index.php?option=content&task=view&id=145](http://www.gemini.edu/index.php?option=content&task=view&id=145)).

Due to the large cost and size of the instrument, Gemini was encouraged to explore possible partnerships with the Subaru Observatory and the Japanese community to share telescope time and resources in making WFMOS a reality. Since the Subaru Observatory was in the process of designing a large prime-focus corrector for an ambitious new wide-field imager, the HyperSuprime Camera, a cost-saving opportunity was identified if the two wide-field instruments could share the corrector.

Hence, in September 2005, the Gemini Observatory issued an announcement of opportunity for two conceptual design studies of WFMOS on the Subaru telescope ([www.gemini.edu/index.php?option=content&task=view&id=148](http://www.gemini.edu/index.php?option=content&task=view&id=148)). The design studies are currently under way. Two teams have been chosen for the study, one led by the Anglo-Australian Observatory (Sam Barden, PI) and the other by California Institute of Technology (Richard Ellis, PI). Both teams include large international collaborations, and are working in concert with members of the Subaru community to investigate the scientific potential of WFMOS. In parallel, the Subaru Observatory has commissioned a design study for the prime-focus corrector and is examining telescope and facility modifications needed to accommodate WFMOS and HyperSuprime Camera. The groups are also investigating the impact of both instruments on the telescope and operations.

Independent of the proposed collaborative development of WFMOS, Gemini and Subaru have already initiated a program to share telescope time starting in 2006B using existing instrumentation at these observatories. Subaru and Gemini have also jointly organized two science meetings – “Probing the Dark Universe with Subaru and Gemini,” in November 2005, and “Cosmology Near and Far: Science with WFMOS,” in May 2008 (see accompanying article) – to explore the wide range of astrophysics enabled by both HyperSuprime Camera and WFMOS working in concert.

The conceptual design studies for WFMOS are scheduled to be completed by March 2009. If the conceptual design studies are favorably reviewed by Subaru and Gemini, and if the two observatories can identify the resources to build WFMOS and reach an equitable and mutually beneficial agreement for its development and operation, WFMOS will proceed to a build phase. The incredible scientific promise of both WFMOS and HyperSuprime Camera will—we hope—motivate the observatories to collaborate on these instruments, for the mutual benefit of the Gemini and Subaru communities. We look forward to the successful completion of the concept studies.

## Kyoto Joint Subaru/Gemini Science Conference in May 2009

The Subaru and Gemini observatories have announced a jointly sponsored science meeting to be held 18-21 May 2009 at Kyoto University, Kyoto, Japan. The two main goals of the conference are to promote a mutual understanding of both communities via the presentation of research results from the two observatories, and to highlight the international nature of astronomy. Other goals include:

- Better understanding of the Subaru and Gemini instruments and science programs
- Fostering scientific collaborations
- Defining key areas of ‘niche science’ for both observatories

In addition to the joint science meeting, a Gemini Users Meeting will be held on May 22 at the same venue. For additional information, see [www.gemini.edu/node/10981](http://www.gemini.edu/node/10981). We encourage interested US astronomers to plan to attend this broad international science meeting.



# Report of a Classical Gemini-Subaru Exchange Program Observing Run

*Moire Prescott (University of Arizona)*

The copious Lyman-alpha ( $L\alpha$ ) emission of Ly $\alpha$  nebulae and their association with other galaxy populations, such as Lyman Break Galaxies and Submillimeter Galaxies, has led to the suggestion that Ly $\alpha$  nebulae are sites of ongoing massive galaxy formation sitting in overdense regions of the Universe.

Through the 2008A Gemini-Subaru Time Exchange Program, my collaborators Nobunari Kashikawa (National Astronomical Observatory of Japan), Yuichi Matsuda (Kyoto University), PhD advisor Arjun Dey (NOAO), and I were awarded one night at the Subaru Observatory. We used the SuprimeCam wide-field optical imager to complete a one-square-degree intermediate-band imaging survey of the environment of one of the largest Ly $\alpha$  nebulae known (Dey et al. 2005, ApJ, 629, 654). Unlike most other large Ly $\alpha$  nebulae, which have been found in narrowband surveys of known galaxy overdensities, the Dey et al. Ly $\alpha$  nebula was found at  $z \sim 2.7$  without any a priori knowledge of its surroundings. This provided an unbiased test of the association between large Ly $\alpha$  nebulae and overdense environments. Subaru/SuprimeCam was an ideal match for our program, combining a large aperture, wide-field coverage, and a high throughput intermediate-band filter centered on the  $z=2.7$  Ly $\alpha$  emission line.

In early April, Arjun Dey and I flew to Hawaii for our one-night run at Subaru. To avoid the height of festival tourist season in Hilo, where the Subaru base facility is located, we were assigned to summit observing and spent the night prior to our run halfway up Mauna Kea at Hale Pohaku. The support astronomer for SuprimeCam, Dr. Miki Ishii, accompanied us to the summit to begin calibrations and introduced us to the telescope operator, Alanna Garay. While waiting for sunset, we donned construction helmets and walked through the labyrinthine network of hallways and elevators, thoughtfully labeled in English and Japanese, to pay a visit to the telescope. The Subaru dome is immense, but the telescope itself is tucked so snugly into its chamber, it is difficult to appreciate just how big the 8.2 meters of glass and the brilliant blue 22.2-meter telescope structure really are.

We encountered a few dome and rotator issues during evening twilight, but thanks to the support provided by Garay and Ishii, and the 0.6-1.1 arcsec seeing throughout the night, we succeeded in completing our one-square-degree survey on schedule. Prior to the run, we had submitted an operations file specifying all the observing commands to be used during the run. During the observations, the file can be edited by the operator or support astronomer in real time to tweak a position, change an exposure time, repeat an observation, or skip an entire section of the program, as necessary. We found the net result to be a remarkably efficient observing system that

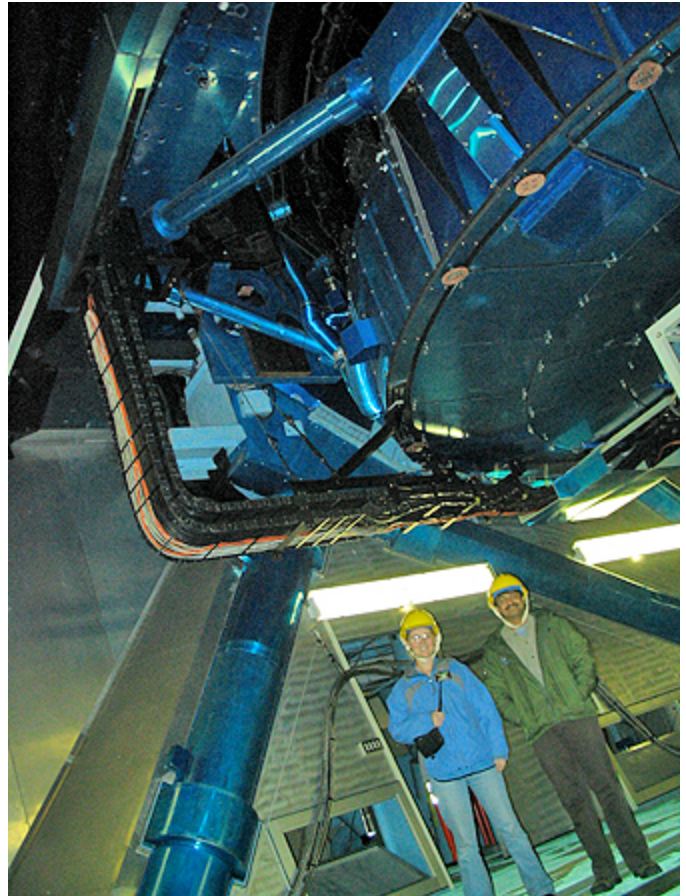

Moire Prescott and Arjun Dey under the Subaru telescope.

preserved the flexibility we needed to adapt to changing weather conditions and scientific priorities.

Results from a pilot Subaru/SuprimeCam survey in 2007A showed that the Ly $\alpha$  nebula is associated with a large  $20 \times 50$  Mpc overdense structure, as traced by the Ly $\alpha$ -emitting galaxy population (Prescott et al. 2008, ApJ, 678, 77), providing strong confirmation of the association between large Ly $\alpha$  nebulae and overdense regions of the Universe. A preliminary analysis of our complete one-square-degree Subaru/SuprimeCam survey hints that the overdense structure may stretch even further.

# Detailed Aspects of Technical Reviews for T-ReCS and Michelle

*Ken Hinkle, Dick Joyce & Jayadev Rajagopal*

**M**id-infrared (mid-IR) imaging and long-slit, medium-resolution spectroscopy are provided at Gemini North by Michelle and at Gemini South by T-ReCS. Although Michelle and T-ReCS were manufactured at different times by different groups, and the operational details are slightly different for each, their imaging and medium-resolution spectroscopic capabilities are similar. Michelle and T-ReCS are facility “workhorse” instruments designed to take advantage of the mid-IR optimization of the Gemini telescopes.

Mid-IR observing is intrinsically difficult because both the sky and the telescope itself produce background radiation that is far brighter than nearly all astronomical targets. The background in the best parts of the mid-IR is 0 magnitude per square arcsecond, and it varies both spatially and temporally. The Gemini Mid-IR Resources Web pages contain a nice overview on mid-IR observing prepared by Pat Roche of Oxford University (go to [www.gemini.edu/sciops/instruments/mid-ir-resources/](http://www.gemini.edu/sciops/instruments/mid-ir-resources/), then click on “Ground-based mid-IR observing”).

To cancel the background for imaging and low-resolution spectroscopy, a nearby position on the sky is observed by tilting the telescope secondary a few times per second. This “chops” the instrument field of view between the target position and an adjacent sky position. Subtracting the pairs of images eliminates the majority of the sky background. However, the telescope is a source of mid-IR radiation and tilting the secondary changes the optical axis and thus the background flux. This results in an additional radiation component from the chopping which must be cancelled by moving (“nodding”) the telescope. The detector must be read out before it reaches saturation (typically 20 milliseconds). The read out, chop, and nod frequencies all depend on the background, with limits set by the electronics and telescope.

The Gemini telescopes can guide at only one of the chop positions. Therefore, even if the nod and chop are set to keep all the images on the chip, half the observation is unguided and not suitable for most applications. The chop duty cycle and the time required for the telescope to nod and then stabilize further increases the overhead. The net observing efficiency is thus about 25 percent.

It is important to consult the Gemini instrument Web pages for the exact overheads. For instance the overhead is larger in the Q band and for polarimetry, but smaller for “stare” mode spectroscopy. The limited amplitude of the chopping and nodding add additional complexity to the observation of extended fields. Also note that the ITC does not necessarily assume the correct overhead. It is your responsibility to confirm that the ITC overhead is correct or to enter the correct value. The ITC never includes the telescope pointing/setup time, so 15 minutes must always be added.

The nodding, chopping, and detector readout times are all computed automatically at the telescope, depending on wavelength and conditions. Thus the observer need only request the total time required after including the overhead. The overall configuration of the modes of the mid-IR instruments is similarly straightforward. The challenging aspect of writing (and reviewing) proposals with these instruments arises from the performance limitations discussed above that are imposed by the high background from the telescope and sky. The factors that determine the choice of observing constraint are thus quite different from those which are important at optical wavelengths.

For example, image quality, which is often an important constraint at optical wavelengths, is far less critical in the mid-IR, since the Gemini telescopes deliver near diffraction-limited images under almost all seeing conditions. The factors which limit mid-IR performance are water vapor (WV) and cloud cover (CC). The atmospheric transmission at the short end of the N band and through the entire Q band is determined by water vapor, so moderate to high WV values will saturate the detector in the Si1 and Q band filters. Filters such as Si2 and Si3 in the clean part of the N band can be used under moderate WV conditions, as can the Si4 and Si5 filters, although they are slightly more sensitive to water vapor. Even light cirrus clouds emit significant and time variable IR radiation, making mid-IR observations virtually impossible for all but very bright sources. Clear (CC=50) conditions are essential for observations of faint sources in the N band or any observations in the Q band filters.

For a more detailed discussion, see [www.gemini.edu/sciops/instruments/mir/SPIE\\_Mason\\_et\\_al.pdf](http://www.gemini.edu/sciops/instruments/mir/SPIE_Mason_et_al.pdf).

## Gemini News from the Marseille SPIE Meeting

*Ken Hinkle, Ron Probst, Jayadev Rajagopal & Mark Trueblood*

**T**he SPIE sponsors a meeting on astronomical telescopes and instrumentation every other year. The latest meeting took place in Marseille, France in June. The four authors attended because of other observatory functions, but here we report on Gemini-related presentations.

Traditionally, each of the major observatories is asked to give a presentation on their instrumentation program. This year’s presentation

on Gemini instrumentation was given by Joe Jensen. Highlights from Joe’s talk, which covered both current and future instrumentation, included recommissioning plans for GNIRS at Gemini North and commissioning plans for FLAMINGOS-2 and NICI at Gemini South. Plans for commissioning the multi-conjugate adaptive optics system for Gemini South (GeMS-Canopus) were also reviewed. Progress on the Gemini Planet Imager (GPI), now in the final design phase, was described. Finally, Joe discussed Gemini’s planned construction

*continued*

*Gemini News from the Marseille SPIE Meeting continued*



**Mark Chun (University of Hawaii) and Mark Trueblood (NOAO) having a quiet chat after a day's session at the June 2008 SPIE meeting.**

of a ground-layer adaptive optics system (GLAO) and the wide-field multi-object spectrograph (WFMOS) project. Further details on many of these projects could be found in the various talks and poster sessions at the meeting.

The sessions on adaptive optics (AO) systems included summary papers on science results. Addressing solar system science with AO, F. Marchis (University of California, Berkeley) noted scheduling advantages of ground-based telescopes as compared to spacecraft. These include temporal continuity (monitoring) for long periods and target-of-opportunity observations for special events. Operationally, speakers stressed the need for accurate differential, non-sidereal tracking, and for high-quality ephemerides for target objects. A.-M. Lagrange (Observatoire de Grenoble) spoke about extrasolar planet detection. She noted that a large number of surveys are under way with 8- to 10-meter telescopes. While existing data sets are heterogeneous, they are now large enough for initial statistical analyses. Pressing needs are to improve and test models of planet formation, and instrumentally for spectroscopy coupled to Extreme AO systems, and lots of telescope time!

Bruce Macintosh (Lawrence Livermore National Laboratory) gave a talk on GPI. He discussed the evolution of the instrument in the final detailed design and reviewed the predicted performance. GPI will use high-order AO employing a MEMS deformable mirror to

produce contrast levels of  $10^7$ . An integral-field spectrometer will allow the characterization of young (<2 billion year old) extrasolar giant planets.

Production of apodizing occulting masks with a variable density profile is a technical challenge for GPI and other coronagraphic instruments, which is being vigorously pursued by several vendor-instrument project teams. Sandrine Thomas (University of California Observatories) reported successful laboratory tests of a GPI prototype mask. Test results for similar masks in development for other ground and space instruments were also presented by P. Martinez et al. (European Southern Observatory [ESO]), D. Moody Jr. et al. (Jet Propulsion Laboratory), and M. Beaulieu et al. (Université de Montréal).

R. Smith and collaborators (California Institute of Technology) presented a poster explaining "how flatfielding can hurt you" with CCD detectors, and a pair of papers on a model of and a calibration approach for image persistence in infrared (IR) detectors at low flux levels. G. Finger et al. (ESO) reported on performance and calibration of Hawaii-2RG IR arrays, including a readout technique that extends dynamic range. An ESO-Teledyne group presented initial cryogenic tests of an Array Specific Integrated Circuit (ASIC), an approach with promise of simplifying IR-array electronics. While not Gemini specific, these technologies and methodologies may see use with Gemini instruments.

Steve Eikenberry (University of Florida) delivered a presentation on FLAMINGOS-2, a 1- to 2.5-micron near-infrared imager and multi-object spectrograph that is scheduled for its pre-ship acceptance test in August 2008 (see accompanying instrumentation article). FLAMINGOS-2 will be suitable for use with the GeMS-Canopus system as well as with natural seeing.

Several posters were presented on the GeMS-Canopus effort. GeMS involves the construction of a laser service enclosure (LSE) at the equivalent of the Nasmyth platform. Chas Cavedoni, with a large number of collaborators from the Gemini staff, presented a poster describing the LSE. It is a class-10,000 clean room that is  $8 \times 2.5 \times 2.5$  meters in dimension and weighs 5100 kg.

Celine d'Orgeville, again with a large number of co-investigators from Gemini, gave a poster on the GeMS laser guide star facility. This featured the equipment necessary to propagate the laser from the LSE to the laser launch telescope (LLT). The LLT and resulting laser guide star images were also described. Gelys Trancho and Gemini co-investigators described the highly complex operation of the GeMS in a paper on the operation model. GeMS-Canopus requires five laser guide stars and two to four natural guide stars. There was also a paper by I. Lee and collaborators from Lockheed Martin Coherent Technologies, Gemini, and Keck on the 50 W guide star laser required by GeMS. The laser uses diode-pumped solid-state 1064 and 1319 nanometer oscillators with sum-frequency mixing in a non-linear crystal to produce the very high power required by GeMS. 

## US Participation in the Gemini Planet Finding Science Working Group

When the Gemini Board approved an allocation of up to 50 nights with the Near Infrared Coronagraphic Imager (NICI) for a multi-year planet search campaign, they charged the Gemini Observatory to ensure that the time would be used wisely. In response, the Observatory has formed a Planet Finding Science Working Group (PFSWG) to oversee the NICI campaign.

This group's initial charge is to confirm that NICI is ready for action by comparing the original NICI performance estimates, which were prepared for the campaign call for proposals a couple of years ago, with the on-sky commissioning data provided by the Gemini NICI commissioning team. The PFSWG will also receive input from the campaign team, which is led by Michael Liu (University of Hawaii), Laird Close (University of Arizona), and Mark Chun (University of Hawaii). The PFSWG will then make a recommendation to the Gemini director about readiness to proceed with the NICI campaign. Once the campaign is underway, the PFSWG will annually review the campaign team's progress and make a recommendation about allocating the remaining campaign time.

The members of the PFSWG are Ron Probst, chair (NOAO), Olivier Guyon (Subaru Observatory), Karl Haisch (Utah Valley University), Dave Koerner (Northern Arizona University), Steve Ridgway (NOAO), Pat Roche (University of Oxford), and Raquel Salmeron (Australian National University).

The PFSWG will have another significant responsibility. The Gemini Planet Imager (GPI), the next-generation coronagraphic exoplanet instrument with a high-order AO system and integral field spectrograph, is presently under construction under the leadership of Bruce Macintosh (Lawrence Livermore National Laboratory). A science team will be selected through open competition in 2009 to conduct an extensive survey with GPI. The PFSWG will participate in the proposal review and team selection process for the GPI science campaign once this opportunity is announced by the Gemini Observatory. This task flows naturally from the NICI assessment and survey oversight tasks that the PFSWG is undertaking initially.

— Ron Probst (NOAO) and  
Joe Jensen (Gemini Observatory)

## NGSC Instrumentation Program Update

*Verne V. Smith & Mark Trueblood*

This article gives a status update on Gemini instrumentation being developed under the oversight of the NGSC, with progress since the June 2008 NOAO/NSO Newsletter.

### Florida Multi-Object Imaging Near-Infrared Grism Observational Spectrometer-2 (FLAMINGOS-2)

*FLAMINGOS-2 is a near-infrared multi-object spectrograph and imager for the Gemini South telescope. FLAMINGOS-2 will cover a 6.1-arcmin-diameter field at the standard Gemini f/16 focus in imaging mode, and will provide multi-object spectra over a 6.1 × 2-arcmin field. It will also provide a multi-object spectroscopic capability for Gemini South's multi-conjugate adaptive optics system. The University of Florida is building FLAMINGOS-2 under the leadership of Principal Investigator Steve Eikenberry.*

The effort to cool the MOS cryostat by adding a second cold head appears to have been successful. The University of Florida instrument team has successfully achieved and maintained desired temperatures in the MOS cryostat, permitting integration testing to proceed.

Previous electronic noise issues in the cryostat were resolved, yielding acceptable read noise levels. New noise effects were tracked down to a combination of array controller firmware and software, and a software work-around was developed to remove the image artifacts until the controller firmware could be upgraded. The instrument is now yielding clean images that can be analyzed for image quality, noise, and other test parameters.

Testing of the on-instrument wave front sensor was completed, with analysis of the results remaining to be performed as of this writing.

The pre-ship acceptance test is scheduled to be held in Gainesville in August. Following that test, the Gemini Observatory will produce a punch list of items to be completed before the instrument is shipped to Cerro Pachón. The authors expect it will take the University of Florida team at least a few weeks to complete the punch list before shipping the instrument in early northern autumn.

As of June, the University of Florida team reports that 96 percent of the scheduled work leading to FLAMINGOS-2 final acceptance by Gemini had been completed.

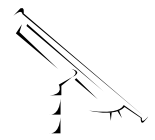

## 2009A Observing Proposals Due 30 September 2008; Survey Proposals Due 15 September 2008

*Dave Bell*

Standard proposals for NOAO-coordinated observing time for semester 2009A (February - July 2009) are **due by Tuesday evening, 30 September 2008, midnight MST**. Proposals for new Survey programs are due by 15 September 2008, and require a letter of intent to have been sent in July. The facilities available this semester include the Gemini North and South telescopes, Cerro Tololo Inter-American Observatory (including SOAR), Kitt Peak National Observatory, and community-access time with Keck, Magellan, and the MMT.

Proposal materials and information are available on our Web page ([www.noao.edu/noaoprop/](http://www.noao.edu/noaoprop/)). There are three options for submission:

- **Web submissions** – The Web form may be used to complete and submit all proposals. The information provided on the Web form is formatted and submitted as a LaTeX file, including figures that are “attached” to the Web proposal as encapsulated PostScript files.
- **Email submissions** – As in previous semesters, a customized LaTeX file may be downloaded from the Web proposal form, after certain

required fields have been completed. “Essay” sections can then be edited locally and the proposal submitted by e-mail. Please carefully follow the instructions in the LaTeX template for submitting proposals and figures.

- **Gemini’s Phase-I Tool (PIT)** – Investigators proposing for Gemini time **only** may optionally use Gemini’s tool, which can be downloaded from [www.gemini.edu/sciops/P1help/p1Index.html](http://www.gemini.edu/sciops/P1help/p1Index.html).

Note that proposals for Gemini time may also be submitted using the standard NOAO form, and that proposals which request time on Gemini plus other telescopes **MUST** use the standard NOAO form. PIT-submitted proposals will be converted for printing at NOAO, and are subject to the same page limits as other NOAO proposals. To ensure a smooth translation, please see the guidelines at [www.noao.edu/noaoprop/help/pit.html](http://www.noao.edu/noaoprop/help/pit.html).

The addresses below are available to help with proposal preparation and submission.

Web proposal materials and information  
Request help for proposal preparation  
Address for thesis and visitor instrument letters, as well as  
consent letters for use of PI instruments on the MMT  
Address for submitting LaTeX proposals by email  
Gemini-related questions about operations or instruments

CTIO-specific questions related to an observing run  
KPNO-specific questions related to an observing run  
Keck-specific questions related to an observing run  
MMT-specific questions related to an observing run  
Magellan-specific questions related to an observing run

[www.noao.edu/noaoprop/](http://www.noao.edu/noaoprop/)  
[noaoprop-help@noao.edu](mailto:noaoprop-help@noao.edu)  
  
[noaoprop-letter@noao.edu](mailto:noaoprop-letter@noao.edu)  
[noaoprop-submit@noao.edu](mailto:noaoprop-submit@noao.edu)  
[usgemini@noao.edu](mailto:usgemini@noao.edu)  
[www.noao.edu/gateway/gemini/support.html](http://www.noao.edu/gateway/gemini/support.html)  
[ctio@noao.edu](mailto:ctio@noao.edu)  
[kpno@noao.edu](mailto:kpno@noao.edu)  
[keck@noao.edu](mailto:keck@noao.edu)  
[mmt@noao.edu](mailto:mmt@noao.edu)  
[magellan@noao.edu](mailto:magellan@noao.edu)

# Community Access Time Available in 2009A with Keck, Magellan, and MMT

Dave Bell

As a result of awards made through the National Science Foundation Telescope System Instrumentation Program (TSIP) and a similar earlier program, telescope time is available to the general astronomical community at the following facilities in 2009A:

• **Keck Telescopes**

A total of fourteen nights of classically scheduled observing time will be available with the 10-meter telescopes at the W. M. Keck Observatory on Mauna Kea. All facility instruments and modes are available. For the latest details, see [www.noao.edu/gateway/keck/](http://www.noao.edu/gateway/keck/).

• **Magellan Telescopes**

A total of eight nights will be available for classically scheduled observing programs with the 6.5-meter Baade and Clay telescopes at Las Campanas Observatory. For updated information on avail-

able instrumentation and proposal instructions, see [www.noao.edu/gateway/magellan/](http://www.noao.edu/gateway/magellan/).

• **MMT Observatory**

Fourteen nights of classically-scheduled observing time to be available with the 6.5-meter telescope of the MMT Observatory. Previous requests have disproportionately used our allocation of dark and grey time, so bright time proposals are particularly encouraged. For further information, see [www.noao.edu/gateway/mmt/](http://www.noao.edu/gateway/mmt/).

Community-access time at the Hobby-Eberly telescope is no longer available. A list of instruments we expect to be available in 2009B can be found at the end of this section. As always, investigators are encouraged to check the NOAO Web site for any last-minute changes before starting a proposal.

## Observing Request Statistics for 2008B Standard Proposals

	No. of Requests	Nights Requested	Average Request	Nights Allocated	DD Nights (*)	Nights Previously Allocated	Nights Scheduled for New Programs	Over-subscription for New Programs
<b>GEMINI</b>								
GEM-N	112	123.45	1.1	66.173	0	0	66.173	1.87
GEM-S	61	77.66	1.27	48.08	0.8	0	48.08	1.62
<b>CTIO</b>								
CT-4-meter	47	161.5	3.44	110	2	0	110	1.47
SOAR	13	43.6	3.35	29.5	3	0	29.5	1.48
CT-1.5-meter	7	51	7.29	21.7	0	6	15.7	3.25
CT-1.3-meter	7	26.5	3.79	6.89	0	0	6.89	3.85
CT-1.0-meter	8	59	7.38	73	0	6	67	0.88
CT-0.9-meter	18	91.9	5.11	67.1	0	0	67.1	1.37
<b>KPNO</b>								
KP-4-meter	47	203	4.32	77.5	6	14	63.5	3.2
WIYN	20	67.5	3.38	49.5	0	2	47.5	1.42
KP-2.1-meter	28	152	5.43	133	0	0	133	1.14
WIYN-0.9-meter	2	6	3	6	0	0	6	1
<b>Keck, MMT, Magellan</b>								
Keck-I	21	38.3	1.82	11	0	0	11	3.48
Keck-II	30	35	1.17	8	0	0	8	4.38
Magellan-I	7	15	2.14	4	0	0	4	3.75
Magellan-II	5	11	2.2	4	0	0	4	2.75
MMT	11	18.7	1.7	15.5	0	0	15.5	1.21

\*Nights allocated by NOAO Director

# CTIO Instruments Available for 2009A

Spectroscopy	Detector	Resolution	Slit
<b>4-meter Blanco[1]</b>			
Hydra + Fiber Spectrograph	SiTe 2K×4K CCD, 3300-11,000Å	700 - 18000, 45000	138 fibers, 2" aperture
R-C Spectrograph	Loral 3K×1K CCD, 3100-11,000Å	300-5000	5.5'
<b>4-meter SOAR[2]</b>			
OSIRIS IR Imaging Spectrograph	HgCdTe 1K×1K, JHK windows	1200, 1200, 3000	3.2', 0.5', 1.2'
Goodman Spectrograph	Fairchild 4K×4K CCD, 3100-8500Å	1400, 2800, 6000	5.0'
<b>1.5-meter[3]</b>			
Cass Spectrograph	Loral 1200×800 CCD, 3100-11,000Å	<1300	7.7'
Fiber echelle spectrograph	SiTe 2K×2K CCD, 4020-7300Å	20000-42000	2.4" fiber
Imaging	Detector	Scale ("/pixel)	Field
<b>4-meter BLANCO</b>			
Mosaic II Imager	8K×8K CCD Mosaic	0.27	36'
ISPI IR Imager	HgCdTe (2K×2K 1.0-2.4mm)	0.3	10.25'
<b>4-meter SOAR[2]</b>			
Optical Imager	E2V 4K×4K Mosaic	0.08	5.25'
OSIRIS IR Imaging Spectrograph	HgCdTe 1K×1K	0.33, 0.14	3.2', 1.3'
Goodman Spectrograph	Fairchild 4K×4K CCD	0.15	7.2' diameter
<b>1.3-meter2 [3,4]</b>			
ANDICAM Optical/IR Camera	Fairchild 2K×2K CCD	0.17	5.8'
	HgCdTe 1K×1K IR	0.11	2.0'
<b>1.0m[5]</b>			
Direct Imaging	Fairchild 4K×4K CCD	0.29	20'
<b>0.9-meter[6]</b>			
Direct Imaging	SiTe 2K×2K CCD	0.4	13.6'

[1] The R-C Spectrograph should be out-performed by the Goodman Spectrograph on SOAR, in general. A comparison guide will be made available at proposal-time.

[2] The amount of science time available on SOAR in 2008B will be at least 50%. The spectral resolutions and slit lengths for the OSIRIS imaging spectrograph correspond to its low-resolution, cross-dispersed, and high-resolution modes, respectively. In the cross-dispersed mode, one is able to obtain low-resolution spectra at JHK simultaneously. The Goodman spectrograph is expected to be available in single-slit mode. Imaging mode is also available, but only with U,B,V,R filters.

[3] Service observing only. The Fiber Echelle is a new capability, see the NOAO Proposals Web page and this newsletter for more information.

[4] Proposers who need the optical only will be considered for the 1.0m unless they request otherwise. Note that data from both ANDICAM imagers is binned 2×2.

[5] Classical observing only - Observers may be asked to execute up to 1 hr per night of monitoring projects which have been transferred to this telescope from the 1.3m. In this case, there will be a corresponding increase in the scheduled time. No specialty filters, no region of interest.

[6] Classical or service, alternating 7-night runs. If proposing for classical observing, requests for 7 nights are strongly preferred.

# Instruments Expected to be Available for 2009A

GEMINI NORTH	Detector	Spectral Range	Scale ("/pixel)	Field
NIRI	1024×1024 Aladdin Array	1-5μm R~500-1600	0.022, 0.050, 0.116	22.5", 51", 119"
NIRI + Altair (AO- Natural or Laser)	1024×1024 Aladdin Array	1-2.5μm + L Band R~500-1600	0.022	22.5"
GMOS-N	3×2048×4608 CCDs	0.36-1.0μm R~670-4400	0.072	5.5' 5" IFU
Michelle	320×240 Si:As IBC	8-26μm R~100-30,000	0.10 img, 0.20 spec	32"×24" 43" slit length
NIFS	2048×2048 HAWAII-2RG	1-2.5μm R~5000	0.04 × 0.10	3" × 3"
NIFS + Altair (AO- Natural or Laser)	2048×2048 HAWAII-2RG	1-2.5μm R~5000	0.04 × 0.10	3" × 3"
GEMINI SOUTH	Detector	Spectral Range	Scale ("/pixel)	Field
Phoenix	512×1024 Aladdin Array	1-5μm R<70,000	0.085	14" slit length
GMOS-S	3×2048×4608 CCDs	0.36-1.0μm R~670-4400	0.072	5.5' 5" IFU
T-ReCS	320×240 Si:As IBC	8-26μm R~100,1000	0.09	28" × 21"
NICI	1024×1024 (2 det.) Aladdin III InSb	0.9-5.5μm Narrow Band Filters	0.018	18.4" × 18.4"

\*Please refer to the NOAO Proposal Web pages in September 2008 for confirmation of available instruments.



# KPNO Instruments Available for 2009A

Spectroscopy	Detector	Resolution	Slit Length	Multi-object
<b>Mayall 4-meter</b>				
R-C CCD Spectrograph	T2KB/LB1A/F3KB CCD	300-5000	5.4'	single/multi
MARS Spectrograph	LB CCD (1980×800)	300-1500	5.4'	single/multi
Echelle Spectrograph	T2KB/F3KB CCD	18000-65000	2.0'	
FLAMINGOS[1]	HgCdTe (2048×2048, 0.9-2.5μm)	1000-1900	10.3'	single/multi
IRMOS[2]	HgCdTe (1024×1024, 0.9-2.5μm)	300/1000/3000	3.4'	single/multi
<b>WIYN 3.5m[3]</b>				
Hydra + Bench Spectrograph[9]	STA1 CCD	700-22000	NA	~85 fibers
SparsePak[4]	STA1 CCD	700-22000	IFU	~82 fibers
<b>2.1-meter</b>				
GoldCam CCD Spectrograph	F3KA CCD	300-4500	5.2'	
FLAMINGOS[1]	HgCdTe (2048×2048, 0.9-2.5μm)	1000-1900	20.0'	
Exoplanet Tracker (ET)[5]	CCD (4K×4K, 5000-5640 Å)	See Note	Fiber (2.5")	
Imaging	Detector	Spectral Range	Scale	Field
<b>Mayall 4-meter</b>				
CCD MOSAIC-1	8K×8K	3500-9700 Å	0.26	35.4'
NEWFIRM[6]	InSb (mosaic, 4-2048×2048)	1—2.3μm	0.4	28.0'
SQIID	InSb (4-2048×2048)	JHK	0.39	3.3'
FLAMINGOS [1]	HgCdTe (2048×2048)	JHK	0.32	10.3'
<b>WIYN 3.5-meter</b>				
Mini-Mosaic[7]	4K×4K CCD	3300-9700 Å	0.14	9.3'
OPTIC[7]	4K×4K CCD	3500-10000 Å	0.14	9.3'
WHIRC[8]	VIRGO HgCdTe (2048×2048)	0.9-2.5μm	0.10	3.3'
<b>2.1-meter</b>				
CCD Imager[10]	T2KB CCD	3300-9700 Å	0.305	10.4'
SQIID	InSb (4-512×512)	JHK	0.68	5.8'
FLAMINGOS[1]	HgCdTe (2048×2048)	JHK	0.61	20.0'
<b>WIYN 0.9-meter</b>				
CCD MOSAIC-1	8K×8K	3500-9700 Å	0.43	59'

[1] FLAMINGOS Spectral Resolution given assuming 2-pixel slit. Not all slits cover full field; check instrument manual. FLAMINGOS was built by the late Richard Elston and his collaborators at the University of Florida. Dr. Steve Eikenberry is currently the PI of the instrument.

[2] IRMOS, built by Dr. John MacKenty and collaborators. Availability will depend on proposal demand and block scheduling constraints.

[3] A new Volume Phase Holographic (VPH) grating, 740 l/mm, is now available for use. Please contact Di Harmer for information.

[4] Integral Field Unit, 80"×80" field, 5" fibers, graduated spacing

[5] Exoplanet Tracker (ET) is an instrument provided by Dr. Jian Ge of the University of Florida and his colleagues. It enables very high precision measurements of radial velocities for suitably bright enough targets. Details regarding this instrument are available via our instrument web pages. It is capable of providing Doppler precision of 4.4 m/s in 2 minutes for a V = 3.5 mag, G8V star.

[6] Please see [www.noao.edu/ets/newfirm/](http://www.noao.edu/ets/newfirm/) for more information. Permanently installed filters include J, H, and Ks. Please see NEWFIRM Web pages for update on availability/scheduability of other filters.

[7] OPTIC Camera from U of Hawaii is anticipated to be available through an agreement with Dr. John Tonry of the University of Hawaii. This instrument may be assigned to those that request to use Mini-Mosaic if this substitution still meets proposed imaging needs and making such an assignment would further observatory support constraints. Fast guiding mode of operation of OPTIC is now a supported mode for NOAO users of the instrument. Optic may not be available in 2009A. If it is, availability begins in June 2009.

[8] WHIRC, built by Dr. Margaret Meixner (STScI) and collaborators, will be available for use during 2009A (no WTTM). It will be available for shared-risk use with the WTTM module.

[9] STA1 is the offered Bench CCD. A 3300 l/mm VPH grating will be available in shared-risk mode. Assuming successful commissioning in fall 2008, a new collimator will also be in use. Observers should plan for the same dispersion and wavelength range, but a factor of ~2 increase in throughput. Depending on the configuration, there may be up to a 20% reduction in the instrumental resolution. Observers are encouraged to view [www.wiyn.org/instrument/bench\\_upgrade.html](http://www.wiyn.org/instrument/bench_upgrade.html) for further details to help plan observations.

[10] While T2KB is the default CCD for CFIM, use of F3KB may be justified for some applications and may be specifically requested; scale 0.19"/pix, 9.7"×3.2' field. If T2KB is unavailable, CFIM may be offered with T2KA (scale 0.305"/pix, 10.4' field) or with F3KB to best match proposal requirements. [www.noao.edu/kpno/ccdchar/ccdchar.html](http://www.noao.edu/kpno/ccdchar/ccdchar.html)

## MMT Instruments Available for 2009A

	Detector	Spectral Range	Scale ("/pixel)	Field
BCHAN (spec, blue-channel)	Loral 3072 × 1024 CCD	0.32-0.8μm	0.3	150"
RCHAN (spec, red-channel)	Loral 1200 × 800 CCD	0.5-1.0μm	0.3	150"
MIRAC3 (mid-IR img, PI inst)	128 × 128 Si:As BIB array	2-25μm	0.14, 0.28	18.2, 36"
MegaCam (optical imager, PI)	36 2048×4608 CCDs	0.32-1.0μm	0.08	24'
Hectospec (300-fiber MOS, PI)	2 2048×4608 CCDs	0.38-1.1μm	R ~1K	60'
Hectochelle (240-fiber MOS, PI)	2 2048×4608 CCDs	0.38-1.1μm	R ~32K	60'
SPOL (img/spec polarimeter, PI)	Loral 1200 × 800 CCD	0.38-0.9μm	0.2	20"
ARIES (near-IR imager, PI)	1024×1024 HgCdTe	1.1-2.5μm	0.04,0.02	20", 40"
SWIRC (wide n-IR imager, PI)	2048×2048 HAWAII-2	1.0-1.6μm	0.15	5'
CLIO (thermal-IR AI camera, PI)	320×256 InSb	H,K,L,M	0.05	16×13"
MAESTRO (optical echelle, PI)	4096×4096	0.32-1.0μm	0.15	

## Magellan Instruments Available for 2009A

	Detector	Resolution	Spectral Range	Scale ("/pixel)	Field
<b>Magellan I (Baade)</b>					
PANIC (IR imager)	1024×1024 Hawaii		1-2.5μm	0.125	2'
IMACS (img/slslit/mslit)	8192×8192 CCD	R~2100-28000	0.34-1.1μm	0.11, 0.2	15.5', 27.2'
MagIC (optical imager)	2048×2048 CCD		BVRI, u'g'r'i'z'	0.07	2.36'
<b>Magellan II (Clay)</b>					
LDSS3 (mslit spec/img)	4096×4096 CCD	R~200-1700	0.4-0.8 μm	0.19	8.25' circ.
MIKE (echelle)	2K×4K CCD	R~22000-83000	0.32-1.0μm	0.12-0.13	

## Keck Instruments Available for 2009A

	Detector	Resolution	Spectral Range	Scale ("/pixel)	Field
<b>Keck 1</b>					
HIRESb/r (optical echelle)	3× MM-LL 2K×4K	30k-80k	0.35-1.0μm	0.19	70" slit
NIRC (near-IR img/spec)	256 x 256 InSb	60-120	1-5μm	0.15	38"
LRIS (img/slslit/mslit)	Tek 2K×4K, 2×E2V 2K×4K	300-5000	0.31-1.0μm	0.22	6x8'
<b>Keck 2</b>					
ESI (optical echelle)	MIT-LL 2048 × 4096	1000-6000	0.39-1.1μm	0.15	2x8'
NIRSPEC (near-IR echelle)	1024 × 1024 InSb	2000, 25000	1-5μm	0.18 (slitcam)	46"
NIRSPA0 (NIRSPEC w/AO)	1024 × 1024 InSb	2000, 25000	1-5μm	0.18 (slitcam)	46"
NIRC2 (near-IR AO img)	1024 × 1024 InSb	5000	1-5μm	0.01-0.04	10-40"
OSIRIS (near-IR AO img/spec)	2048 × 2048 HAWAII2	3900	0.9-2.5μm	0.02-0.1	0.32-6.4"
DEIMOS (img/slslit/mslit)	8192 × 8192 mosaic	1200-10000	0.41-1.1μm	0.12	16.7×5'

Interferometer

IF (See [msc.caltech.edu/software/KISupport/](http://msc.caltech.edu/software/KISupport/))



# Single Sign-on and the Virtual Observatory as an Operational Facility

*Christopher J. Miller & Irene Barg*

The Virtual Observatory (VO) is a distributed system of data, tools, and services—there is no brick and mortar building. By definition, the VO is the integrated whole of a large, heterogeneous and internationally distributed network of facilities. Many astronomers have principal investigator (PI) data taken by NOAO, Space Telescope Science Institute, Spitzer, Chandra, XMM, etc. These data live in secure archives for proprietary periods before going public. The archives act like banks, storing and protecting your valuable data.

One of the goals of the VO is to provide astronomers with highly effective tools and services to discover and access all of their data through portals. A simple (but not ideal) analogy is a financial Web service that provides account aggregation. For example, many online banks will collect user names and passwords to all of your various financial accounts (e.g., credit cards, loans, retirement plans, investment plans, etc.). The service then provides you with a summary of your financial data in one location. The service works by collecting the balances from each separate account.

As users, we often experience “password fatigue” as we try to keep track of different user names and passwords for each account. Arguably, our assets become less secure as notes with account and password information begin to litter our offices.

The solution to this problem is called Single Sign-on (SSO), and it is becoming more popular every day on the World Wide Web. For instance, you can log onto your Google, Blogspot, and YouTube accounts using the same user name and password. At NOAO, the Data Products Program (DPP) has implemented the SSO mechanism into the NOAO VO Portal ([www.nvo.noao.edu](http://www.nvo.noao.edu)), and we hope that other astronomical archives will follow our lead in the near future.

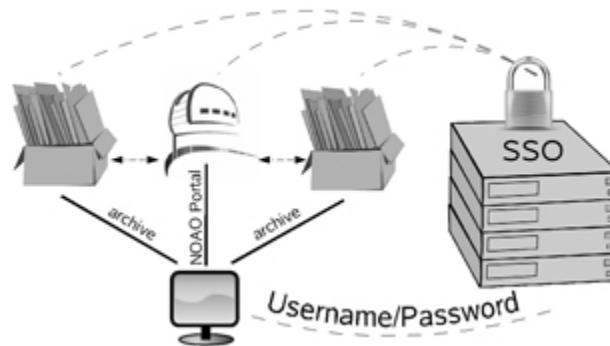

Single Sign-on (SSO) will enable astronomers to enter their user names and passwords one time and gain access to proprietary data and services across multiple archives and portals. NOAO is now operating a production-quality mirror of the SSO login service to ensure a high quality of service for our users.

As part of the transition from development into an operational US VO facility, DPP operations has been moving toward mirrored services. These will better guarantee availability of services, especially critical services like the VO SSO, which is used by the NOAO VO Portal to grant PIs access to their proprietary data.

In June 2008, the NOAO VO Portal in Tucson and La Serena was deployed into production using a single interface for NVO authentication. To this end, I. Barg, along with C. Miller, N. Saavedra, and M. Fleming (NOAO), and R. Plante and B. Baker (National Center for Supercomputing Applications) have built VMware Linux servers to host an SSO mirror ([nvoauth1.tuc.noao.edu](http://nvoauth1.tuc.noao.edu)) and create one of the first production-level, secure, VO login services. Check it out at [sso.us-vo.org](http://sso.us-vo.org).

## The All-Sky Camera Project

*David Walker*

The All-Sky Camera (ASCA) project started at CTIO in 2002 under the direction of Roger Smith. It later evolved under Hugo Schwarz into a system that has been implemented around the world at 10 different sites.

The ASCA takes images of the entire visible hemisphere every 30 seconds in blue, red, Y, and Z filters, giving enhanced contrast for the detection of clouds, airglow, and the near-infrared. Animation is used to show movement of clouds. An additional narrowband filter is centered on the most prominent sodium line to monitor any human-made light pollution near the site. The camera detects aircraft lights and contrails, satellites, meteors, meteorites, and local light polluters.

It can be used for stellar extinction monitoring and for photometry of transient astronomical objects.

The ASCA can also show wandering planets, diurnal rotation of the sky, the zodiacal light, and even the occasional bird. The archival use of the ASCA images will allow us to measure the trends of extinction variations, airglow changes, and long-term light pollution from cities and towns near the observatory.

The project was started as a basic cloud monitor, using only a blue filter, and it was later enhanced with other filters. The final version being used on the Large Synoptic Survey Telescope (LSST) and Thirty

*continued*

*All-Sky Camera Project continued*



Figure 1: All-sky camera at Kitt Peak National Observatory.

Meter Telescope (TMT) campaigns uses a filter wheel with five filters to monitor clouds (blue), airglow (red), the near-infrared (Y, Z) and artificial light pollution (sodium). The ASCA is fully automatic and, apart from periodic maintenance, requires no human intervention.

The ASCA is made up of a CCD camera with a filter wheel and a 180-degree field-of-view fish-eye lens. The equipment is placed in a simple tubular housing on top of a pillar three meters high with a small acrylic dome to protect it from rain, snow, wind, and dust. A ladder provides access, and the whole housing with camera can be removed easily for maintenance. Marked positions assure that the orientation of the ASCA is the same after being removed for maintenance or repair.

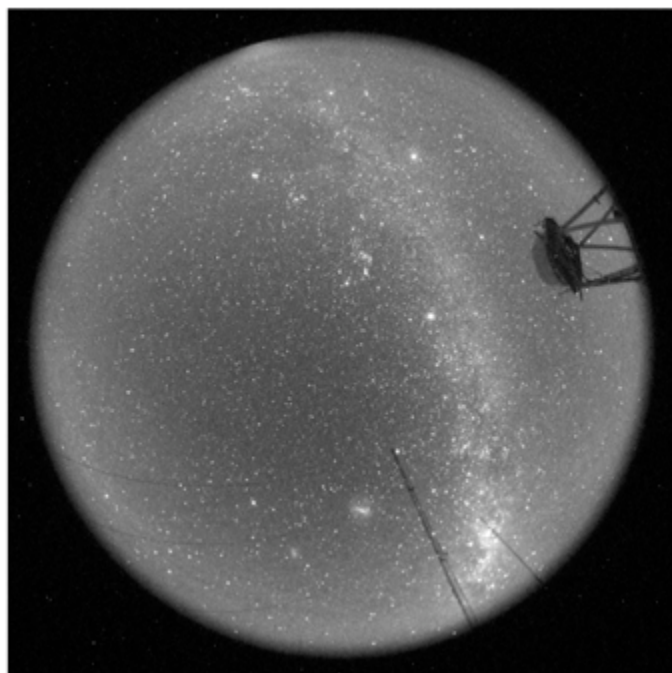

Figure 2: A single all-sky image from Cerro Armazones taken on the night of 8 December 2007.

From carefully selected locations, the ASCAs can see most of the sky (and at observatories and the site test locations, most of the surrounding domes or telescopes). The cameras have lines of sight to all towns and cities on the horizon to monitor light pollution.

One computer controls the ASCA while another stores and processes the images. The control computer, located in the ASCA housing, demands a location with an Internet connection and power. The processing computer resides at the respective observatory and receives the data by downloading the images from the all-sky control computer over the Internet.

The all-sky systems are deployed to sites in Chile at Cerro Tolar (TMT), Cerro Armazones (TMT), Cerro Tolonchar (TMT), Cerro Las Campanas (Carnegie), Cerro Tololo (CTIO), and Cerro Pachón (SOAR); in Mexico at San Pedro Martir (TMT-LSST); in the US at Hawaii (TMT) and Kitt Peak (KPNO); and, finally, in the Arctic at 83 degrees North (in a partnership with Canada).

TMT and LSST use the ASCAs for evaluating light pollution at their different sites. Each of the five sites in the TMT site-testing program has an ASCA as part of the site testing equipment. All five sites are very dark on average, with the only light pollution coming from nearby communities or work sites. For light pollution to be an issue for TMT, it must extend above the 65-degree zenith angle, which is the lower limit for TMT observations.

The TMT all-sky data has shown that there are great differences in light pollution levels even at the same site. This demonstrates the necessity of examining as many nights as possible from each of the sites. Noticeable changes occur due to instrumentation, light sources

*continued*

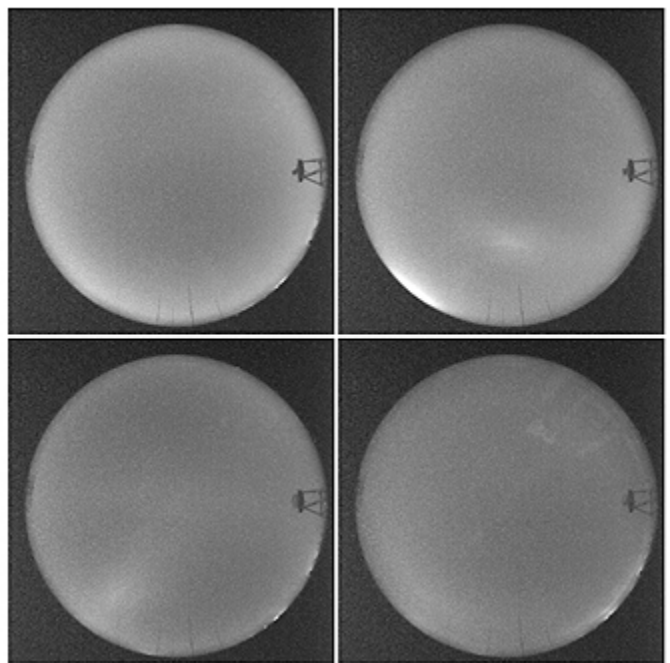

Figure 3: A set of light pollution analysis images from Cerro Tolar, showing the various features that can appear in the data.

*All-Sky Camera Project continued*

appearing or disappearing over time, patches of clouds near light sources at times, and the appearance of the Milky Way galaxy in the data. It is critically important to examine each light pollution analysis image and, if necessary, raw data to conclude what the different features are in the images, and then combine the analysis of several images to determine the effects of light pollution at the sites.

The data from the ASCAs on NOAO sites also hold the promise of providing better understanding of the scientific data obtained from all of the telescopes on a nightly basis. Now that ASCAs are operating at CTIO, KPNO, and SOAR, we are starting a program to archive the ASCA images together with the scientific data in the NOAO Science Archive. In the future, both principle investigators and archival users will be able to retrieve the ASCA images along with their science data to aid their scientific research. ■

## Upcoming Data Products Program Meetings and Events

*Christopher J. Miller*

The (northern) fall is a busy time of year for the NOAO Data Products Program (DPP) team. Software deliverables are scheduled for release at the National Virtual Observatory Summer School (NVOSS), the Astronomical Data Analysis Software and Systems (ADASS) conference, and the next American Astronomical Society meeting in January. All DPP software needs to be operationally deployed and tested prior to these milestones.

Important dates over the next few months:

The fourth NVOSS will be held in Santa Fe, New Mexico from September 2–11. NOAO is sending staff members Dave De Young, Mike Fitzpatrick, and Chris Miller, and many students. The NVOSS is where students learn to use and develop modern astronomical tools and services that are VO-compliant. See [www.us-vo.org](http://www.us-vo.org).

The International Virtual Observatory Alliance (IVOA) will hold its semi-annual interoperability meeting in Baltimore at the end of October. The IVOA is the forum where standards are set so that astronomical tools, services, and archives can operate together. See [www.ivoa.net](http://www.ivoa.net).

The ADASS annual meeting will be held November 2–5 in Quebec City, Quebec. Themes this year include new algorithms, future large projects, software processes, and Web technologies. See [www.adass.org](http://www.adass.org).

As always, the NOAO DPP will have a strong presence at each of the events. Our central goal is to promote involvement of the US scientific community in the Virtual Observatory through user support, operational efficiency, and software development.



## Fiber Echelle Spectrograph Finds New Life as Exoplanet Hunter

*A. Tokovinin*

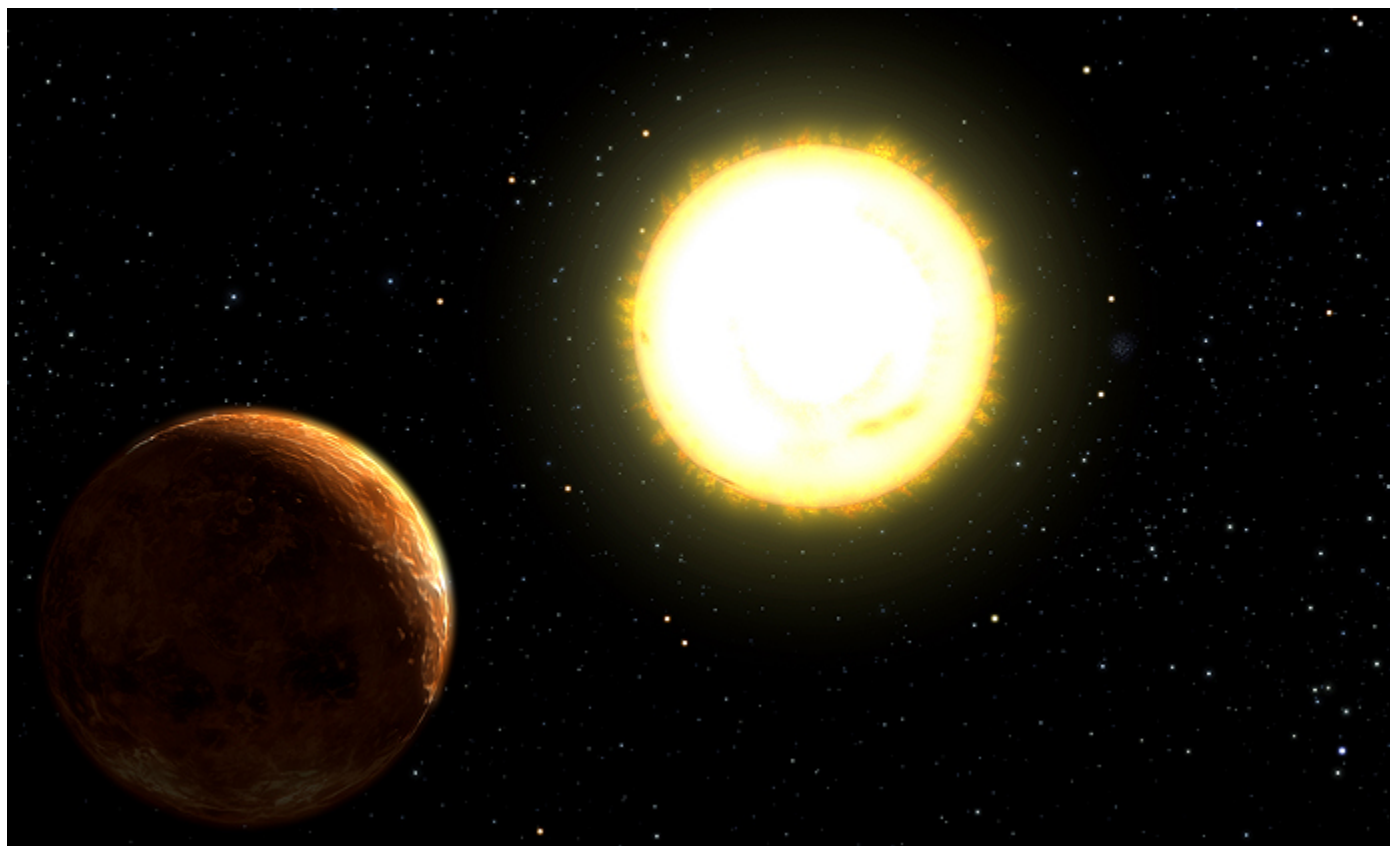

Could a large rocky extrasolar planet like this one be orbiting Alpha Centauri?

Artist's concept: NASA

**N**OAO South users were left without any capability for high-resolution stellar spectroscopy upon the retirement of the Echelle Spectrograph from the Blanco 4-meter telescope in 2006. However, this old spectrograph has found a new life owing to a recent collaboration between NOAO and the California and Carnegie Planet Search team led by Debra Fischer (San Francisco State University [SFSU]) and Geoff Marcy (University of California, Berkeley).

Their idea is to obtain a large number of precise radial-velocity (RV) measurements of a selected target: our closest stellar neighbor, Alpha Centauri. The purpose of this "Mission to Alpha Cen" is to search for terrestrial planets around this solar-type star by reaching unprecedented RV accuracy (on the order of 10 centimeters per second) and dense time coverage. Availability of large blocks of telescope time is a key factor in this project.

The spectrograph was moved to the coudé room of the CTIO 1.5-meter telescope, and an entirely new fiber link was implemented. Stellar light is directed to the spectrograph from the guiding module, so echelle spectroscopy can be combined with other work (such as the R-C Spectrograph) without instrument changes. The spectrograph optics are maintained in a fixed configuration covering the range from

4020 to 7300 Ångströms, with no changes allowed. A two-pixel resolving power of  $R=42,000$  is available at the expense of some light loss.

The system efficiency is about one percent, so to reach a signal-to-noise ratio of 100 per pixel ( $S/N=100$  per pixel), a  $V=7$  star must be exposed for 10 minutes. By opening the slit, we gain 1.5 in the efficiency at  $R=20,000$ . The scrambling properties of the fiber result in a very good stability, on the order of 0.01 pixel (36 meters per second [m/s]). An iodine cell brings the RV precision to  $\sim 1$  m/s for single observation, with further precision gain expected by averaging hundreds of observations per night. In fact, up to 300 measurements per night were obtained during the first test run of the instrument (May 19 to June 15). See the manual and other materials at [www.ctio.noao.edu/~atokovinin/echelle/](http://www.ctio.noao.edu/~atokovinin/echelle/).

The fiber-linked Echelle Spectrograph is now available to the SMARTS consortium and to general NOAO users. A data reduction pipeline for precise RV is under development at SFSU. We are investigating the possibility of replacing the old spectrograph with a new, more efficient design. The 2K SITe CCD with its Arcon controller also must be replaced in the longer term.

## Progress on the SOAR Adaptive Module

*Brooke Gregory & Nicole S. van der Blik*

The SOAR Adaptive Module (SAM) is coming together in the optics lab of NOAO South in La Serena. The photo shows optical engineer Roberto Tighe (right) and software engineer Rolando Cantarutti testing the real-time adaptive optics software, with all of the final opto-mechanical components placed in the SAM module.

Meanwhile, work proceeds in parallel on completion of control electronics, cabling of the module, design of the Laser Guide Star system (for the second phase), and design of the detector mount and Dewar for the SAM imager (SAMI).

The instrument is currently scheduled to be commissioned on the SOAR 4.1-meter telescope in Natural Guide Star mode in mid 2009. The laser system is scheduled for commissioning a year later.

For more pictures and updates on the integration of SAM, go to [www.ctio.noao.edu/new/Telescopes/SOAR/Instruments/SAM/](http://www.ctio.noao.edu/new/Telescopes/SOAR/Instruments/SAM/).

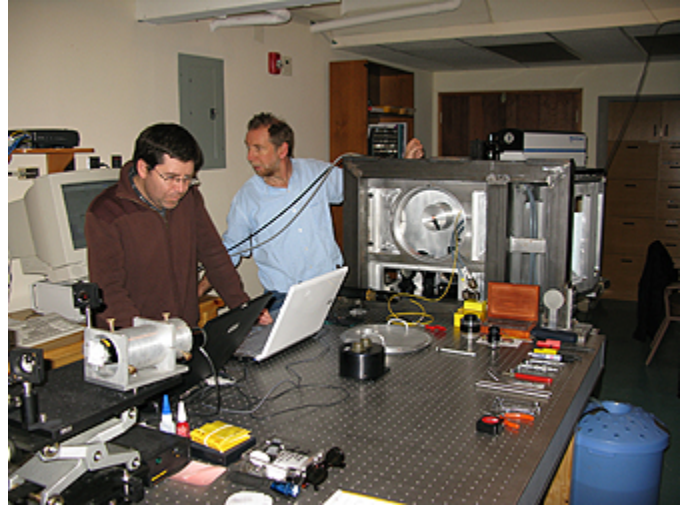

## Students Wanted for REU at CTIO

Cerro Tololo Inter-American Observatory (CTIO) offers six undergraduate research assistantships during the northern winter semester 2008-2009 through the NSF-funded Research Experiences for Undergraduates (REU) program. The CTIO REU program provides an exceptional opportunity for undergraduates considering a career in science to engage in substantive research activities with scientists working at the forefront of contemporary astrophysics. Student participants will work on specific research projects in areas such as galaxy clusters, gravitational lensing, supernovae, planetary nebulae, stellar populations, star formation, variable stars and the interstellar medium, in close collaboration with members of the CTIO scientific and technical staff. Furthermore, the program emphasizes observational techniques and provides opportunities for direct observational experience using our state-of-the-art telescopes and instrumentation.

Participants must be enrolled as full-time undergraduate students during the REU program, and must be citizens or permanent residents of the United States. The program will run for 10 weeks, from approximately January 12 to March 22. Complete applications, including applicant information, official transcripts and two or three letters of recommendation should be submitted no later than 5 October 2008. For more information (and the application), please see [www.ctio.noao.edu/REU/reu.html](http://www.ctio.noao.edu/REU/reu.html). Women and minorities are strongly encouraged to apply.

— Ryan Campbell

# Blanco TCS Upgrade

Timothy Abbott

As part of the normal cycle of upgrades, and with a view toward proper support of the NOAO Extremely Wide-Field Infrared Imager (NEWFIRM) and the Dark Energy Camera, CTIO staff are currently engaged in upgrading the telescope control system (TCS) of the Blanco 4-meter telescope. The team working on the Blanco project is the same one that produced the SOAR TCS and that is developing the Large Synoptic Survey Telescope TCS. All three telescopes are expected to profit from synergies among the three systems and we are seeking to make them overlap as much as possible.

The Blanco upgrade will see the replacement of all TCS components outside of the driver motors and drive trains, from encoders to power drivers. Wherever possible, we will use off-the-shelf components with an anticipated market lifetime of at least five years. Tape encoders will be used on both axes, and programmable power drivers have been purchased to improve motor control. The modularized and distributed computer system is comprised of Linux boxes communicating via Ethernet. State-of-the-art software control will allow us to optimize telescope accelerations and slew trajectories, particularly to avoid exciting telescope resonances. Slew speed must be fast enough to not provide the

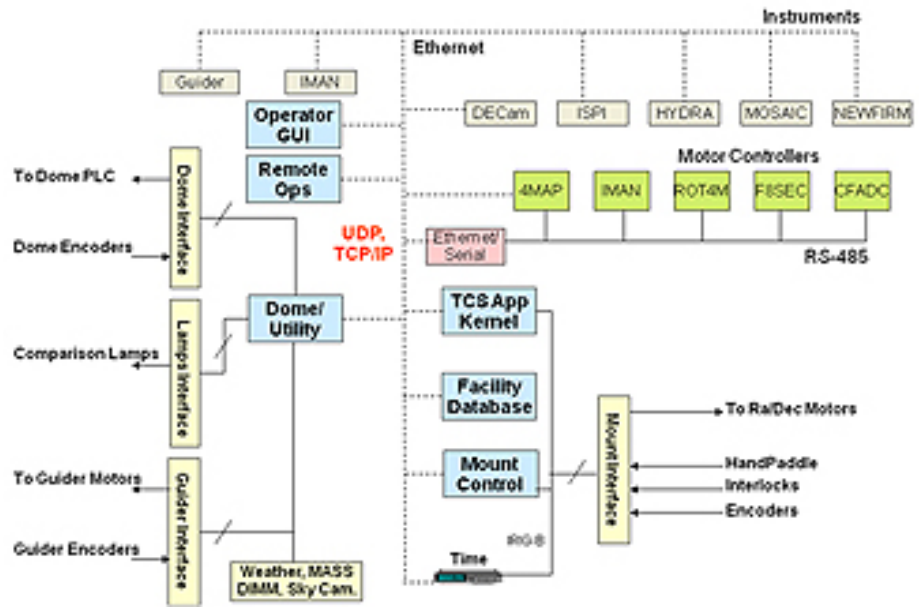

limit for the Dark Energy Survey cadence, which has a field separation of two degrees and readout time of 17 seconds.

Telescope and environment telemetry capabilities will be enhanced and recorded in a database to be useful for all instruments. Modern human/machine interfaces will be provided. The upgrade is specified to proceed

without interrupting normal telescope operations and is expected to be fully functional by January 2010.

The project was summarized in a paper presented at the recent Marseille SPIE conference (T. Abbott et al., 2008, Proc. SPIE 7012, in press). The figure illustrates the upgraded control architecture.

# Chile Staff Changes

Alistair Walker

Verne Smith, director of the NOAO Gemini Science Center (NGSC), and Katia Cunha, NOAO astronomer, moved back to NOAO Tucson in August after almost 18 months in La Serena. Verne and Katia will both continue their involvement with NGSC, so we expect to be able to welcome them back as visitors often in the future—a small consolation for losing two great colleagues and one-eighth of our scientific staff.

Jayadev Rajagopal transitions from Research Associate to Assistant Scientist on October 1. Jayadev has held his present position since

June 2006, where his service roles have consisted of support of infrared (IR) instrumentation at Gemini through NGSC, and work on interferometry development with Steve Ridgway. Jayadev will continue some involvement on these topics at a lower level than at present, with his major service role moving to scientific support for IR instrumentation on the CTIO telescopes, where we are sure his instrumental and observing skills will greatly strengthen our efforts in this area. Over the next 18 months, we are expecting NEWFIRM on the Blanco and the Spartan IR Camera at SOAR, and Jayadev can expect to be very involved with helping

to bring these instruments into full and effective operation.

In September, we welcome Ryan Campbell as our new Research Experiences for Undergraduates (REU) site director. Ryan will start only a few months before our 2009 REU students arrive for their (southern) summer sojourn. Ryan just completed his PhD at New Mexico State University, working on magnetic cataclysmic variables (polars). He is our third recent REU director to be interested in cataclysmic variables, and we are beginning to think that this specialty must be an essential qualification for the job!





## The Meinel Partnership and the Founding of the National Observatory

*Helmut Abt & Buell T. Jannuzi*

As we begin to mark the 50th anniversary of the creation of a national observatory for optical astronomy (see related article in June 2008 *NOAO/NSO Newsletter*), we are saddened by the loss of one of the key early figures in the founding of Kitt Peak National Observatory.

Marjorie Pettit Meinel, professional colleague and life partner of Aden Meinel, the first director of Kitt Peak National Observatory, passed away on June 24 in Henderson, Nevada, at age 86. An accomplished scientist and researcher, Marjorie Pettit Meinel was an essential component of the partnership that realized an optical observatory open to all astronomers based on the merit of their scientific ideas.

Marjorie was the daughter of astronomers Hanna Bard Steele Pettit and Edison Pettit, one of the early staff astronomers of Mount Wilson known for his movies and measurements of solar prominences. Marjorie and Aden were born and attended school in Pasadena, CA, where Aden eventually worked for Don Hendrix, chief optician for the Palomar 200-inch and Lick 120-inch telescopes. They first met at Pasadena Junior College in a special 11th grade high school class for gifted students. Marjorie received her BA in astronomy at Pomona College and her MA in astronomy from Claremont College in 1944. During World War II, Marjorie edited manuscripts and reports for the Navy Rocket Project at Caltech, and Aden became a specialist under Willy Fowler in designing and testing rockets. Near the end of the war, he traveled to Europe with others to learn about German developments in rocketry.

After the war, Aden completed a PhD at Berkeley by building a fast high-dispersion spectrograph and showing that the aurorae were due to incoming protons from the Sun through the identification of the airglow lines. Marjorie suspended her own professional career to raise a family that would grow to include seven children, while continuing to support Aden's professional activities.

In the early 1950s, the Meinels were based at Yerkes Observatory and the University of Chicago, where Aden served as associate director for both the Yerkes and McDonald observatories until 1956. In 1957,

Aden was tapped by the NSF to lead the effort to determine the site of the new national optical observatory.

Aden led the scientific search to identify a first-class site for astronomy and worked with the Tohono O'odham Nation (known then as the Papago Tribe) to secure a lease for the observatory. Kitt Peak, known as Iolkam Duag to the O'odham and part of a range of mountains sacred to the O'odham people, was selected in 1958. The Meinels, who had moved to Phoenix from Illinois during the start of the site-testing program, relocated to Tucson and became involved in all the many aspects of launching the new national observatory, with Aden becoming its first director.



Photo courtesy: A. Meinel

Though Aden left Kitt Peak National Observatory in 1961 for the University of Arizona (where he later served as the third director of Steward Observatory and founded the Optical Sciences Center, now the College of Optical Sciences) and the Jet Propulsion Laboratory (where he and Marjorie were Distinguished Visiting Scientists throughout the 1980s and 90s), he left a lasting imprint on what has evolved into the National Optical Astronomy Observatory.

As was the case throughout his professional career, the strength and support of his partner, Marjorie, was a critical part of Aden's success. The Meinels retired from JPL to Santa Barbara and then to Henderson, where Aden has recently been studying cosmic rays that come from somewhere in the northern sky, as evidenced from elements such as 10Be

and 14C in Greenland and Antarctic ice cores.

Marjorie's ashes were distributed in Red Rock Canyon. Her legacy includes her accomplished children, her books with Aden on solar energy, and her multifaceted help to Aden throughout their 64-year marriage. Seldom has a pair of scientists worked together so closely and so well for so long.

We acknowledge the following online articles about the Meinels at SPIE as valuable sources of information for this article: [spie.org/x25747.xml](http://spie.org/x25747.xml) and [spie.org/x25772.xml?pf=true](http://spie.org/x25772.xml?pf=true).

## Pierre Martin Succeeds George Jacoby as Director of the WIYN Observatory

**P**ierre Martin, previously director of science operations at the Canada-France-Hawaii Telescope (CFHT), will succeed George Jacoby as director of the WIYN Observatory on September 22. The WIYN Observatory includes 3.5-meter and 0.9-meter telescopes on Kitt Peak. The University of Wisconsin, Indiana University, Yale University and NOAO are the member institutions of the WIYN Board.

Jacoby has led WIYN for eight years, successfully supervising a vigorous period of instrumentation upgrades and the initiation of a second generation of instruments for WIYN, including a new near-infrared imager (WHIRC) and a revolutionary new optical imager.

“The WIYN board, on behalf of the entire consortium, expresses its sincere gratitude for the contributions of George Jacoby since he became director in 2000,” said WIYN Board President Charles Bailyn (Yale University). “George has led a talented team that has produced some of the best on-sky performance statistics of any telescope in the world, and he persuaded the partnership to embark on the most ambitious instrumentation project ever attempted by a 4-meter class facility, the One-Degree Imager. George has set an imposing standard for those who will follow.” Jacoby will be returning to NOAO as a member of the scientific staff.

“We’re delighted to have Pierre on board” Bailyn added. “He brings outstanding experience from CFHT, and great energy and enthusiasm for what we all hope to do at WIYN.”

“The WIYN consortium offers a modern 3.5-meter telescope with the capability of conducting world-class astrophysical research on a daily basis and a smaller wide-field telescope that is excellent for complementary observations and student training,” Martin said. “I am honored to have been selected for this challenging but quite exciting position.”

During his 11 years at CFHT, Martin has been the support scientist for several instruments.



George Jacoby



Pierre Martin



He also served as manager of the astronomy group and as the project scientist/manager for CFHT queue observing. This mode, developed to optimize observing efficiency, science productivity and data quality, is now the only operational mode for the wide-field imaging and spectroscopy capabilities at CFHT. “Innovative observing modes are one key to the success of modern observatories—they offer scientists reliable, efficient and new possibilities for data acquisition, and they increase the value of the resulting data products,” Martin said.

Martin earned his PhD in astrophysics at the Université Laval (Quebec City) in 1992. He spent three years as a post-doc at the Univer-

sity of Arizona, followed by a two-year fellowship with the ESO New Technology Telescope in Chile. Martin’s scientific interests include the chemical evolution of spiral galaxies, massive star formation, morphology and dynamics of barred spiral galaxies, galactic Cepheid variables, and planetary nebulae. Martin was born in St-Alexis de Matapédia, a small village in the eastern part of the Province of Québec. He is married to Patricia E. Pérez, a PhD graduate of the University of Arizona, and his hobbies include music, drumming, and history.

# Commissioning Work on WHIRC Proceeding Well

*Dick Joyce (NOAO), Heidi Schweiker (WIYN), & Margaret Meixner (STScI)*

Commissioning of the WIYN High-Resolution Infrared Camera (WHIRC) is nearing completion. Following the January 2008 observing run, the operational readout mode and detector bias were established, and succeeding commissioning runs have been used to obtain sensitivity measurements, establish calibration and observing procedures, and complete the observing interface. In addition, WHIRC was used in April, May, and July for shared-risk science observing by scientists from all of the WIYN partner institutions. Initial reports indicate that the observers were pleased with both the instrument performance and relative ease of operation using the WHIRC observing interface.

During the May engineering run, significant progress was made in the integration of WHIRC with the WIYN Tip-Tilt Module (WTTM), and it is now possible to carry out WHIRC offsets while maintaining WTTM guiding. While the use of WHIRC with WTTM in active tip/tilt mode is not being supported for observations in 2008B, we will continue to characterize the performance and establish observing protocols during upcoming engineering and science verification runs. We plan to offer WHIRC with WTTM in shared-risk mode during 2009A, contingent on the availability of WIYN staff to support WTTM operation.

The combination of high spatial resolution and the large complement of narrowband filters make WHIRC a scientifically powerful instrument. Narrowband imaging is similar to optical CCD imaging in that the individual exposure times can be long and the performance is driven by long-term stability, read noise, and dark current. Initial observations through several of the WHIRC narrowband filters have been very encouraging.

Occasional clear intervals during the July observing run were used for deep imaging in the J and Ks bands. The figure shows the results of a one-hour on-source observation ( $12 \times 300$ -second images) of an extragalactic field in the J band, reaching a  $10 \sigma$  limit of  $J=21.4$ .

The two remaining commissioning issues are the excess read noise associated with the instrument rotator and demonstrating the required flat-fielding precision through all of the filters. NOAO/KPNO senior

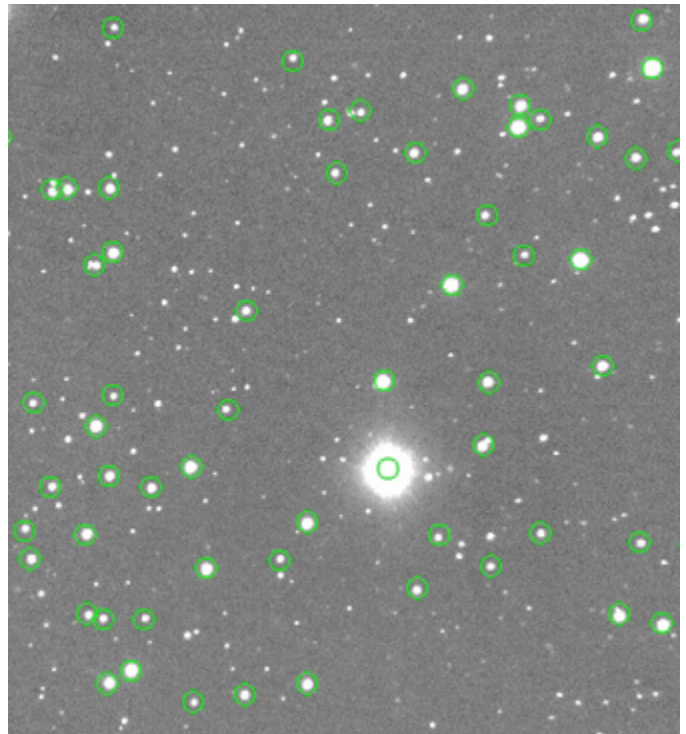

Image of an extragalactic field in the J band. The image (170 arcsec square) was generated from twelve 300-second integrations for a total on-source time of one hour, reaching a  $10 \sigma$  limit of  $J=21.4$ . The circles represent objects in the 2MASS point source catalog brighter than  $J = 16.5$ . Images are 0.5 arcsec FWHM. Image courtesy of Bethany Cobb, Héctor Arce, and Nitza Santiago (Yale University).

engineer Maureen Ellis leads the effort on the noise issue. Principal investigator Margaret Meixner and Ryan Doering at STScI are working on characterizing the flat-fielding

Documentation on WHIRC, including a link to the current version of the User Manual, can be found at [www.noao.edu/kpno/manuals/whirc/WHIRC.htm](http://www.noao.edu/kpno/manuals/whirc/WHIRC.htm).

# Update on KPNO Modernization Projects and Operations

*Tony Abraham & Buell T. Jannuzi*

As recommended by the NSF Senior Review and as discussed in recent *NOAO/NSO Newsletters*, KPNO is working to modernize our telescopes, facilities, and instrumentation. We have just begun a multi-year program to significantly improve the quality of our facilities, and our ability to support the science and education programs scheduled on our telescopes. Our staff also continues to support the operations of numerous other observatories, particularly by assisting in the coating of large mirrors. Here's a brief update on some of our recently completed projects.

**4-meter Instrumentation Clean Room:** To reduce the need for transporting NEWFIRM back and forth to Tucson for filter changes and minor repairs, a 20-foot by 12-foot portable clean room was installed in the former coude room of the Mayall 4-meter telescope. The room will be used for the scheduled servicing of NEWFIRM in November.

**4-meter Dome Rail Inspection/Repair:** Fatigue cracks are beginning to appear in the main rail supporting the dome. A total of 10 cracks have been uncovered and the five most serious fractures were repaired during our summer shutdown of the telescope.

**2.1-meter Cable Wrap Upgrade:** The two main 118-conductor cables and pre-load system for the telescope's electrical system has begun to fail due to conductor fatigue and overburdened mechanical supports. To provide a more robust system, the two large conductors are being replaced with eight 25-conductor cables and new cable tray designs. The new hardware will be installed during September.

**Recent Mirror Coatings:** We recently coated a spherical 3.75-meter mirror that will be used by the University of Arizona to test mirrors for the Giant Magellan Telescope. In the accompanying photo, you can see this mirror being removed from our 4-meter coating chamber. This was not a routine coating, due to the absence of a center hole in the mirror where the chamber coating monitors normally reside



for controlling the film thickness. Modifications were made to the chamber control system and sensors to accommodate this unusual mirror, and in early June a successful coating was accomplished on the first firing attempt.

Kitt Peak annually coats between four to six large aperture mirrors for our own facilities, tenant observatories, and other observatories throughout the United States—and sometimes beyond. Fixed fees are charged for the services and the funds collected are used for maintenance and upgrades of the mirror-coating facility. Other mirrors coated during the last few months include the MDM Observatory 2.4-meter telescope primary mirror, the New Jersey Science & Technology University New Solar Telescope 1.6-meter primary mirror, the Sloan Digital Sky Survey 2.5-meter telescope primary mirror, and our own Mayall 4-meter primary mirror.

## WIYN 0.9-meter Telescope Consortium Seeks New Partners

The WIYN 0.9-meter Telescope Consortium is seeking new partners for their next contract period. The contract term will run from 1 July 2009 through 30 June 2015. The WIYN 0.9-meter telescope, located on Kitt Peak, currently uses the NOAO S2KB and Mosaic imagers, and is building its own new Half-Degree Imager (HDI). HDI will utilize a monolithic 4Kx4K, high and flat U-response CCD with 30 arcmin x 30 arcmin field of view.

Beyond classical observing, partners have access to the WIYN 0.9-meter telescope's special observing modes, which include synoptic, photometric, and opportunity queues.

Please visit [www.noao.edu/0.9m/](http://www.noao.edu/0.9m/) to learn more about the WIYN 0.9-meter telescope and the consortium. Anyone interested in further information should contact Andy Layden ([layden@baade.bgsu.edu](mailto:layden@baade.bgsu.edu)) and Con Deliyannis ([con@astro.indiana.edu](mailto:con@astro.indiana.edu)).

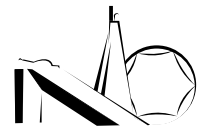

## Director's Corner

Steve Keil

Planning is underway for the next decadal survey for astronomy and astrophysics, and we must ensure that there is strong support for solar science and the tools required to do it. Thus, it is important that solar astronomers take the time to attend and voice your opinions at the meetings held by the main survey committee as well as meetings of the disciplinary sub-committees. The major solar ground-based tools that came out of the previous survey, including the Advanced Technology Solar Telescope (ATST), Frequency Agile Solar Radiotelescope (FASR), and a Synoptic Optical Long-term Investigations of the Sun (SOLIS) network—as well as a strong theoretical program—still need your continuing support. The nomination deadline for Survey Committee membership will be closed by the time this newsletter is published, but nominations for sub-panel membership will be taken through 15 October 2008 via the web ([www7.nationalacademies.org/bpa/Astro2010.html](http://www7.nationalacademies.org/bpa/Astro2010.html)).

For high-resolution solar physics, the ATST has worked its way through all of the processes needed for a new construction start as part of the NSF Major Research Equipment Facilities Construction program, except for the final baseline review which is scheduled for next winter. Given the current status of the project, ATST should not be re-competed in the survey, but would benefit from the endorsement of the decadal review, as was given for Atacama Large Millimeter Array in the previous survey. The ATST enjoys wide support in the solar community and is crucial to a vibrant ground-based solar science program.

In addition to ATST, ground-based solar needs community support for a broad range of activities and facilities. These include theory and modeling, radio observations, helioseismology, and synoptic observations of solar magnetic fields and activity, to mention but a few. We encourage members of the solar community to nominate scientists they feel will strongly support solar physics and the important role that it plays in astrophysics and space physics, and who have the ability to work closely with other communities while clearly advocating for the needs of solar physics.

\* \* \* \*

This year's University of Arizona/National Solar Observatory Summer School in Solar Physics held at Sacramento Peak was again a great success, enjoyed by both students and faculty. The intensive one-week course is designed for beginning graduate and advanced undergraduate students with an interest in the physics of the Sun who may possibly want to pursue a career in solar physics, space physics, or related field.

We would like to extend our special thanks to all of those who gave lectures, including Joe Giacalone (director of the school), Randy Jokipii and Tami Rogers (University of Arizona), Spiro Antiochos (Naval Research Lab), Sam Krucker (University of California-Berkeley), Gene Parker (University of Chicago), Charles Smith (University of New



Assistant Professor Tami Rogers (right) shows the twisting of solar magnetic fields as part of the solar dynamo process, with the help of Research Experiences for Undergraduates student Marrisa Pitterle.

Hampshire), and NSO staff scientists Irene González Hernández, Aimee Norton, Matt Penn, and Han Uitenbroek. We also thank the students who shared their research results through talks and posters. No wild bears tried to crash the lectures this year, unlike last year, making it easier to concentrate! We look forward to next year, and encourage you to let your students know about the summer 2009 course. Information is available at [www.lpl.arizona.edu/SummerSchool08/](http://www.lpl.arizona.edu/SummerSchool08/) or [eo.nso.edu/](http://eo.nso.edu/).

\* \* \* \*

About 220 members of the extended NSO Sunspot family gathered at Sac Peak for a 4th of July reunion. The attendees included employees (past and present) and their family members, including several "Sunspot babies" born to employees who were working there at the time. At least three father-son teams were represented: Frank Hegwer (Sunspot, retired) and Steve Hegwer (NSO/Sunspot), George Streander (Sunspot, retired) and Kim Streander (NSO/Tucson), and Lou and Doug Gilliam (NSO/Sunspot).

Reunion attendees represented the entire 61 years of Sac Peak's history, and many hadn't seen each other since they were small children on the Peak. More than 70 deceased members of the family were memorialized on Sunday, July 6.

The longest association with Sac Peak (in attendance) as a resident/employee was Rebecca (Cope) Coleman, and the longest association

*continued*

*Director's Corner continued*

with Sac Peak (in attendance) were Bill and Jean Davis' daughters Jacque Day, Jeanell Clements, and Linda Bynum. "The reunion was a phenomenal success," said reunion organizer Jackie Diehl of the NSO Director's office at Sac Peak, "not only for those in attendance sharing their stories of life here in Sunspot, but for the many volunteers who put their hearts into making this an event of a lifetime. It was truly enjoyed by all."

We would like to welcome David Elmore, who has joined NSO as ATST instrument scientist. Dave will be located at Sunspot, but will be spending considerable time on the road working with ATST partners to develop instrument packages. Dave will also be doing research and working on ATST-related instrument projects at Sac Peak. 

## First Quarter Deadline for NSO Observing Proposals

The current deadline for submitting observing proposals to the National Solar Observatory is 15 November 2008 for the first quarter of 2009. Information is available from the NSO Telescope Allocation Committee at P.O. Box 62, Sunspot, NM 88349 for Sacramento Peak (SP) facilities ([sp@nso.edu](mailto:sp@nso.edu)) or P.O. Box 26732, Tucson, AZ 85726 for Kitt Peak (KP) facilities ([nsokp@nso.edu](mailto:nsokp@nso.edu)).

Instructions may be found at [www.nso.edu/general/observe/](http://www.nso.edu/general/observe/). A web-based observing-request form is at [www2.nso.edu/cgi-bin/nsoforms/obsreq/obsreq.cgi](http://www2.nso.edu/cgi-bin/nsoforms/obsreq/obsreq.cgi). Users' Manuals are available at [nsosp.nso.edu/dst/](http://nsosp.nso.edu/dst/) for the SP facilities and [nsokp.nso.edu/](http://nsokp.nso.edu/) for the KP facilities. An observing-run evaluation form can be obtained at [ftp.nso.edu/observing\\_templates/evaluation.form.txt](http://ftp.nso.edu/observing_templates/evaluation.form.txt).

Proposers are reminded that each quarter is typically oversubscribed, and it is to the proposer's advantage to provide all information requested to the greatest possible extent no later than the official deadline. Observing time at National Observatories is provided as support to the astronomical community by the National Science Foundation.

## ATST

### *The ATST Team*

The Senate Appropriations Committee approved \$9.5 million for the Advanced Technology Solar Telescope (ATST) in its June 19 markup of the proposed FY 2009 Federal budget: "We will also grow our (under)standing of the sun and its effects on our satellites, telecommunications, and even our electrical power grids," said U.S. Senator Daniel K. Inouye, in announcing several Committee actions. ATST "is a powerful, next generation instrument that will be the world's largest and most capable solar telescopes, and it will offer many scientific breakthroughs." On June 25, the House Appropriations Committee passed the Commerce, Justice, Science, and Related Agencies FY 2009 appropriations bill. The overall Major Research Equipment and Facilities Construction account is funded at \$147.51 million, equal to the President's request. Votes by the House and Senate are pending.

#### **Environmental Impact Statement (EIS)**

The ATST project manager and architect participated in National Historic Preservation Act Section 106 meetings held in June on Maui. The meetings were conducted by the NSF and were attended by the ATST environmental engineering team and consulting parties interested in proposals for mitigation of cultural impacts associated

with building ATST on Haleakalā. Individuals from institutions such as the State Historic Preservation Office, Hawaii Historic Foundation, and Maui Community College, as well as members of the general public, also participated. The meetings were productive and focused on specific, realistic proposals for mitigation. The NSF will hold two more meetings on Maui in late August, leading to the completion of the NHPA Section 106 process, which is required for the completion of the Final EIS for the project.

#### **Science Working Group**

The ATST Science Working Group (SWG), chaired by Thomas Berger of the Lockheed Martin Solar and Astrophysics Laboratory, met in May at the NSO offices in Tucson. A key action from the meeting was to develop at least one ATST Science "use case" for each of the planned commissioning instruments. A strong recommendation to the SWG was to fully develop at least one solid, tested, working, scientifically relevant use case for each instrument. ATST observers then would be encouraged to choose from a menu of available use cases. These will remain the primary examples for each instrument going forward. Draft science use cases were first laid out in the Science Requirements Document and reflected in the science section of the ATST proposal.

*continued*

*ATST continued*



Members of the ATST Science Working Group gather on the steps of the NSO offices in Tucson, after concluding their three-day review of science and engineering issues facing the project.

The ongoing effort will flesh them out in more detail, while taking into account the most recent progress in solar physics, and helping to fill in details for telescope and instrument operations and data handling.

Working groups within the SWG are using a standard template to capture the hypothetical observing programs. The template is modeled as a typical scientific observing proposal, followed by additional information that would more likely be gathered in a planning phase for the experiment. The goal is to provide a common outline on which to describe a range of use cases while guiding the community through various considerations for future observing programs.

The use cases picked by the SWG are: quiet sun chromospheric dynamics and heating; high-cadence and high-resolution observations of solar flares; velocity spectrum of photospheric structures; sunspot penumbral dynamics; magnetic field of prominence cavities; and multi-instrument observing program issues. Initial instrument and observing needs were set and will be refined over the next year.

The SWG identified several different actors who may be involved in an observing program over its lifetime:

- Investigator** - the scientist responsible for a specific experiment.
- Instrument Scientist** - a scientist with detailed knowledge of one or more instruments, who is responsible for preparing experiment definitions for accepted observing programs and determining scientific tasks of the telescope during the observing day.
- Operator** - the telescope controller responsible for the health and safety of the telescope.
- Engineers** - responsible for facility monitoring and maintenance.

ATST will be operated in one of three main modes:

- Instrument Principle Investigator (PI) mode** - A PI brings a new instrument to the telescope for custom observations. The PI remains on the mountain at all times in this case.
- Science PI mode** - A scientist has dedicated time on the telescope to run planned scripts to achieve an approved science observation. The PI may be on the mountain or may be remote.
- Target-of-Opportunity or "Queue" mode** - Tentatively designed as a series of pre-approved programs from which the ATST Scheduling Committee can choose a daily observing schedule, independent of input from a Science or Instrument PI. Details require further study.

Two findings were announced. After some discussion, it was decided that the Visible Broadband Imager (VBI) must maintain both red and blue channel capabilities as a stand-alone instrument in order to meet its science mission. However, the realities of the beam splitting in the coude room may sometimes preclude use of the VBI red channel in combination with other instruments. The SWG accepts this tradeoff. The SWG also found that the transition from disk to coronal observations must be automated and rapid (approximately 10 minutes) to minimize lost observing time.

The next SWG meeting is tentatively scheduled for May 2009, after the NSF-sponsored final design review, at a location to be determined. 

## SOLIS

*Aimee Norton & The SOLIS Team*

Recent science results from the SOLIS instrument include a comparison between observations from the Hinode X-Ray Telescope (XRT) and the STEREO Sun-Earth Connection Coronal and Heliospheric Investigator (SECCHI) instrument to study polar coronal jets and plumes and the corresponding magnetic base of mixed polarities, as identified in SOLIS Vector Spectromagnetograph (VSM) data (Raouafi et al, 2008, ApJ, 682, L137). The study focuses on the temporal evolution of jets and plumes and their relationship.

The data from 7-8 April 2007, show that 26 of 28 jet events (>90 percent) are associated with polar plume material with a one-to-one spatial correspondence of jets to plumes (see figure 1). Extreme ultraviolet (EUV) images from STEREO/SECCHI show plume haze rising from the location of 70 percent of the polar X-ray jets (via Hinode/XRT) and EUV jets with a time delay ranging from minutes to hours. The remaining jets occurred in areas where plume material existed already with an enhancement of the plume after the jet event. Short-lived, jet-like events and small transient bright points are

*continued*

SOLIS *continued*

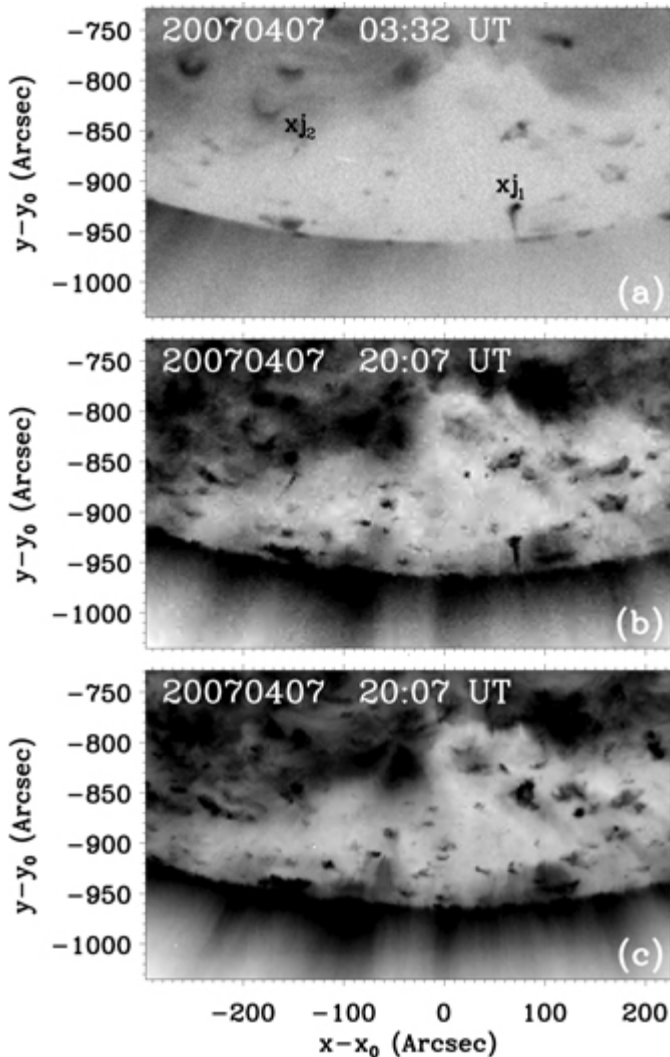

Figure 1: Hinode/XRT snapshots of the southern polar coronal hole recorded on 7 April 2008 showing several X-ray jet events ( $x_{j1}$  and  $x_{j2}$ ). Middle and bottom: 171 Angstrom images from STEREO/SECCHI/EUVI-A of the southern polar hole of the same day. Polar plume haze clearly rise from the same locations as X-ray and EUV jets with a time delay ranging from minutes to hours.

seen at different locations within the base of pre-existing long-lived plumes. X-ray images show rapid evolution of collimated, thin jets to wider plume-like structures associated with time delayed plume haze in the EUV. These observations suggest evidence for X-ray jets being precursors of polar plumes, or of brightenings of plumes.

The SOLIS team has had some positive news regarding funding. The NASA proposal “Data Services Upgrade for SOLIS/VSM Stokes Profile Data” by Henney et al. was recently selected for funding. This proposal to the NASA Solar and Heliospheric Physics Division’s Virtual Observatories for Heliospheric Data program will allow preservation of the VSM full-disk Stokes synoptic data for recent and future advancements in polarimetric data analysis. The proposal was motivated by the opportunity to preserve and make available this unique dataset,

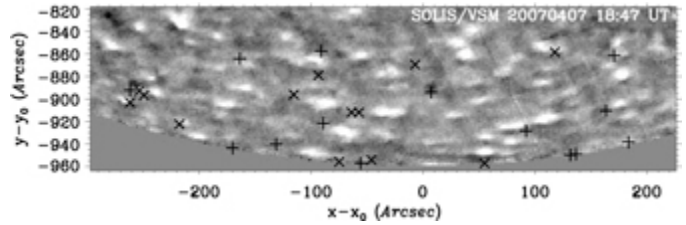

Figure 2: SOLIS VSM line-of-sight chromospheric magnetogram Ca 8542 showing the location of the X-ray jets observed by Hinode/XRT on 7-8 April 2007. Their displacement due to solar differential rotation is taken into account.

and to do the same for future VSM vector observations. The proposed data compression, using the Expansion in Hermite Functions method, and storage is certainly a welcome alternative to the pending deletion of the datasets.

In May, the SOLIS team was invited to submit a full proposal for the National Science Foundation Division of Atmospheric Sciences Mid-Size Infrastructure Opportunity. We proposed to construct two near-duplicates of the Vector Spectromagnetograph instrument of the SOLIS facility, currently operating on Kitt Peak. The replicated VSMs would be operated at established foreign sites by international partners in collaboration with the National Solar Observatory, thereby forming a global network of these forefront instruments for high-precision, synoptic measurements of magnetism on the solar disk.

The primary objective of the VSM network would be to provide nearly continuous vector magnetic field data, in place of the sporadic data presently gathered. We also propose to provide this multi-wavelength vector field data at two levels of the solar atmosphere. The data would support community research on dynamic magnetic phenomena that are relevant to the origins of space weather and geomagnetic disturbances, and may contribute a natural component of long-term global climate change.

Details of the proposed VSM network were presented at the SPIE Astronomical Instrumentation meeting held in Marseille, France in June. The paper, titled “A Global SOLIS Vector-Spectromagnetograph (VSM) Network” by Streadler et al., can be found in the forthcoming SPIE conference proceedings.

The online availability of the calibrated ISS “Sun-as-a-star” spectra was announced in Cool News, a monthly electronic newsletter on the topics of cool stars and the Sun. The ISS data can be downloaded at [solis.nso.edu/iss/](http://solis.nso.edu/iss/), or by visiting the NSO home page at [www.nso.edu](http://www.nso.edu) and clicking on “SOLIS,” where information on the ISS instrument also can be found. Time series of derived parameters characterizing the K line are also given.

The initial alignment of the optics in the Full Disk Patrol (FDP) instrument is completed. We expect to be taking engineering images with this instrument in the near future. The SOLIS team continues to improve upon the treatment of the polarization fringe removal and inversion of the VSM data. The team is positioned for camera replacement and is simply looking for an opportunity during the monsoon season to complete the task. ■



# First Lock for McMath-Pierce Planetary Adaptive Optics System

*Claude Plymate & Andrew Potter*

For several years, the McMath-Pierce Solar Telescope has been used to map Mercury's tenuous sodium exosphere by observing sodium D-line emissions from sunlit sodium atoms in the exosphere. The distribution of sodium atoms over the surface of the planet is found to be non-uniform and changes with time and orbital position. Since the exospheric sodium atoms are produced from the surface of Mercury by the action of solar radiation and particles, these non-uniformities and changes are clues as to how the Sun interacts with the surface of Mercury.

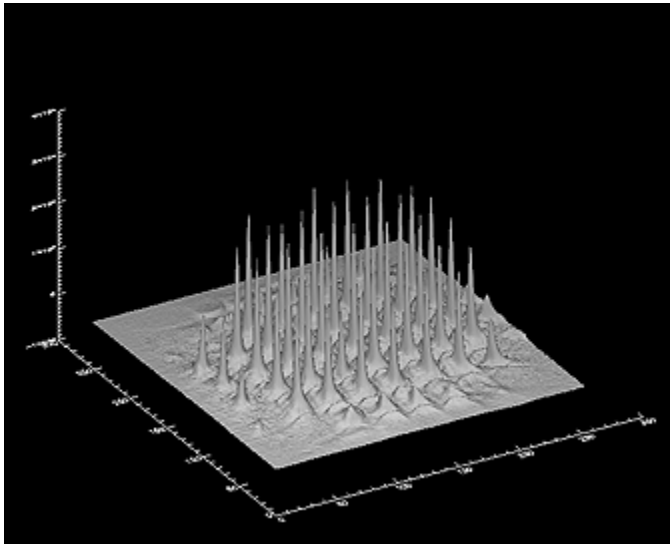

Figure 1. Shack-Hartmann wavefront sensor intensity map showing Mercury in each subaperture.

A ten-slice image slicer is used at the input of the McMath-Pierce stellar spectrograph to divide the planetary disk into an array of spectra. These can be analyzed to produce planetary maps of the sodium D-line emissions, which can then be used to produce maps of sodium atom column density.

Mercury typically subtends at around 6-7 arcsecs, and observations must be conducted during daytime and/or at twilight. Poor seeing during these times can limit the planet's disk to only a few resolution elements across. A planetary adaptive optics (PAO) system, funded through a NASA grant, has been developed at the McMath-Pierce in an effort to improve the spatial resolution of sodium observations across Mercury's disk. To minimize cost, the existing infrared adaptive optics (IRAQ) system at the telescope was used as a model for the PAO system, but optimized for planetary use. The PAO system

was developed around the same commercially available 37-actuator deformable-membrane mirror used on the IRAQ.

First adaptive optics lock on Mercury was demonstrated during an observing run at the McMath-Pierce on 7 May 2008. Figure 1 is a contour map from the wavefront sensor and shows the planet imaged by the Shack-Hartmann lenslet array. The run was hampered by clouds, but we were able to obtain one sodium spectrum through a "sucker hole" under fairly poor seeing conditions.

The resulting sodium map (figure 2) is estimated to have a resolution of 0.7 arcsec, quite close to the 0.5-arcsec resolution of the spectrograph's image slicer, and is roughly a factor of two improvement over previous maps. Further improvement in spatial resolution is expected from refinements in the system software and optics.

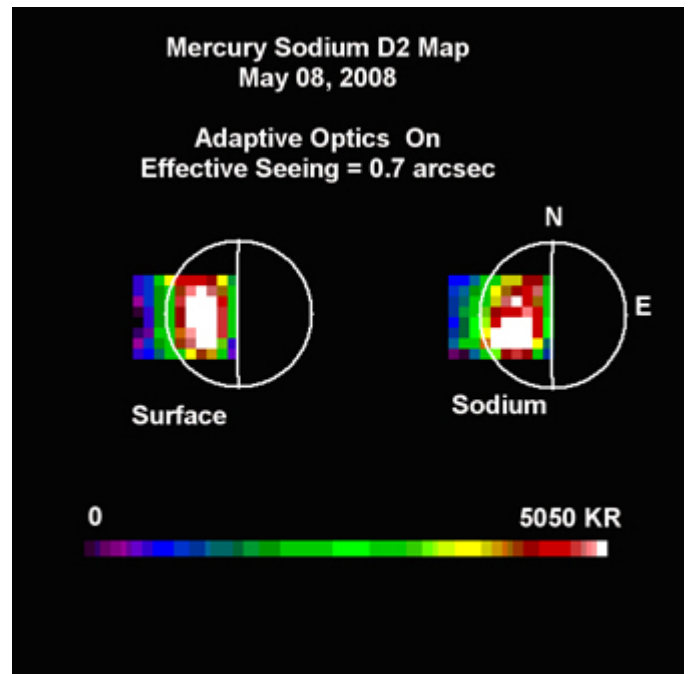

Figure 2. Two views of Mercury measured on 7 May 2008 local time (8 May 2008 UT). The pixels in these images are 0.5-arcsec square. The right view shows the sodium emission intensity in units of kilorayleighs (KR) and the left view shows the surface reflection intensity scaled to match the sodium emission intensity. The sodium emission is clearly offset from the surface reflection, with the preponderance of emission in the southern hemisphere.

# GONG++

Frank Hill & the GONG++ Team

There is very promising news in the search for continued support for GONG in response to the NSF Senior Review's challenge for GONG to find a significant complement of its operating expenses outside the NSF astronomy division. The US Air Force Weather Agency (AFWA) has determined that GONG data fulfills the requirements of their space weather forecast system. This means that there is a very good likelihood that they will fund the installation of an H-alpha observing system in the GONG instruments, and provide a substantial portion of the annual GONG operational budget.

We had an initial teleconference with Air Force personnel based in Nebraska, Colorado, California, and Washington DC in early June, where technical details were initially discussed. A second teleconference was held on July 17. While some details remain to be settled and contracts are yet to be negotiated and signed, the additional H-alpha data set and continued stream of high-cadence magnetograms and helioseismic data promise to provide the community with very important new scientific opportunities.

The H-alpha data will consist of 2048 × 2048-pixel, full-disk on-band images obtained once per minute continually around the clock with the same 90 percent duty cycle that GONG routinely attains. As well as providing a flare patrol for AFWA, this will enable studies of flare evolution, filament dynamics, Moreton waves, etc. with simultaneous magnetograms, Dopplergrams, and subsurface helioseismic data from simultaneous observations and compatible instrumentation. We are looking forward to working with AFWA and increasing GONG's role in space weather.

### Science Highlights

As seen in the Science Highlights section of this *Newsletter*, Rudi Komm has been evaluating the efficacy of the subsurface vorticity measure as a flare predictor. The preliminary results look quite good, and we will be working with the space weather community to further evaluate the forecasting ability of this quantity and its temporal variation. Rudi is also working with a Research Experiences for Undergraduates summer student, Ryan Ferguson from Michigan State University, who has added to the existing data base increasing it to 1009 active regions and has applied a discriminant analysis method to the data to determine which subsurface parameters are best suited to distinguish between flaring and non-flaring active regions.

Kiran Jain has been studying the correlation between the p-mode frequencies and a variety of activity indices as a function of the phase of the solar cycle. Kiran divided the data into three sets corresponding to the rising, high, and declining phases of Cycle 23. She finds that the rising and declining phases of the cycle produce higher correlations between the activity index and the frequency, with a very substantial difference for activity indices that are most affected by sunspots with strong fields. This is another indication that the effect of the magnetic field on the oscillations depends on whether the field is relatively weak and distributed over a large area, or concentrated in localized areas of high field strength.

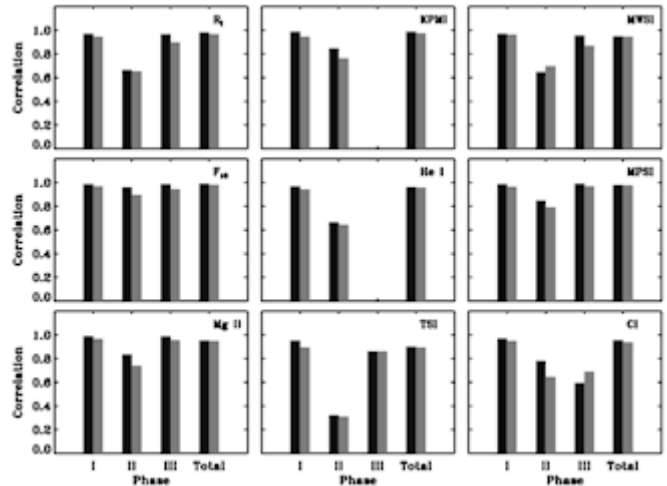

Figure 1. Bar-chart showing phase-wise variation of the Pearson's linear correlation between intermediate degree p-mode frequencies and various activity indices. The complete solar cycle is divided into three phases: the rising (Phase I), high (Phase II) and declining (Phase III) activity. Each activity phase has values for GONG (left) and MDI (right) data. The activity indices used here are; the international sunspot number (RI), the line of sight magnetic field observed at the Kitt Peak Vacuum Telescope magnetic index (KPVI), the Mt. Wilson sunspot index (MWSI), calculated using Mt. Wilson magnetograms, the integrated emission from the solar disk at 2.8 GHz (F10), the equivalent width of the He I 1083 nm solar absorption line (He I), the strength of magnetic plages (MPSI), the ratio of the h and k lines of the solar Mg II feature at 280 nm to the wings at approximately 278 nm and 282 nm (Mg II), the total solar irradiance (TSI), and the total energy emitted by the corona at a wavelength of 530.3 nm (CI). For all indices, except for the F10, the correlation changes significantly from phase to phase. The rising and the declining phases are better correlated than the high-activity phase. The missing values for KPVI and He I for Phase III are due to unavailability of the activity measurements. A substantial decrease in correlation during Phase II is obtained for RI, MWSI and TSI. These indices are most affected by sunspots with strong magnetic fields, while other proxies (e.g. MPSI, Mg II) are sensitive to the weak component of the magnetic field. However, the KPVI and F10 indices are modulated by both components.

### Network Operations & Engineering

Preventive Maintenance (PM) visits were made to Chile and Australia this quarter. After the impromptu camera replacement at CTIO in March, a planned PM visit followed in April. The major task was the replacement of the light-feed turret and subsequent optical alignment, which completes the installation around the network of turrets with improved moisture seals between the moving parts. The old turret was returned to Tucson for refurbishing.

A trip to Learmonth took place in June. The improved clean-air system was deployed to each of the sites. The new pumps have field-

*continued*

GONG++ *continued*



Figure 2. Left, 2008 NSO/GONG IRES participants at a social gathering with students at the Indian Institute of Astrophysics in Bangalore, India. At right (left to right) Driss Takir, Andrea Kunder, IIA Director Dr. Siraj Hasan, Catherine Wu, Erik Larson, and Dr. Kiran Jain.

serviceable parts and can be overhauled onsite with a screwdriver and inexpensive overhaul kit. This is a vast improvement over the previous pumps, which required return to Tucson to be professionally overhauled in our instrument shop. We are now replacing hard disks used by the data caching system during PM visits. Most of these hard drives have been running for over five years now, and we are beginning to experience some failures. Since there is redundancy designed into our data caching system, these failures have not resulted in any lost data.

Earlier in the year, the Udaipur instrument experienced a problem with the turret's pitch-positioning mechanism. This now appears to be the result of moisture intrusion into the area housing the pitch-position resolver. Once the moisture was removed, the turret operated flawlessly until the end of June, when the instrument was shut down for the annual monsoon. How the moisture entered the turret is still undetermined, but the resolver-cover seal is a prime suspect. New sealing material has been implemented on a turret in Tucson and pressure tests indicate the sealing ability is greatly enhanced. Even though the current Udaipur turret was operational at shutdown, it will be replaced at the end of the monsoon season as a risk-mitigation measure.

The Mauna Loa turret continues to experience problems with pitch positioning. The problem is intermittent: some days it is not seen at all and on other days can persist for several hours, making it difficult to troubleshoot. Indicators point to an improperly tuned servo circuit, but attempts to adjust it remotely have not eliminated the problem. Plans to visit the site during the next two months are under discussion.

**Data Operations and Software Development & Analysis**

GONG's Data Storage and Distribution System (DSDS) is now running routine archive and distribution functions on a Linux platform and a link to the new data archive has been added to the GONG Web page. To access the new GUI and peruse the available data products from the home page, go to "Data Archives." Send your comments or suggestions to [smcmanus@nso.edu](mailto:smcmanus@nso.edu).

As we work through the final stages of porting GONG's production software from Sun/Unix to PC/Linux, we get a step closer to retiring the Sun servers. This quarter gongxx, the cornerstone of the original GONG++ processing system, and the L180 tape library were retired. This allowed us to bolster our existing Linux processing capabilities with two dual-CPU, dual-core servers, and 26 terabytes of disk space, which will support a 13-terabyte mirrored FTP archive.

Twenty months worth of GONG magnetogram synoptic maps and field strength models were reprocessed to remove the recently discovered annual periodicity at the poles. The reprocessing effort proved to be a successful implementation of the pipeline manager, Conductor, which allowed the synoptic map pipeline to be distributed across five servers. Conductor was developed by the Planetary Image Research Laboratory at the University of Arizona's Lunar and Planetary Laboratory.

Processing to date includes time series, frequencies, merged velocity and rings for GONG Month 125 (centered at 13 August 2007), with a fill factor of 0.90.

**Program**

We are investigating the possibility of setting up a data node for the upcoming SDO mission, due to be launched soon. This would provide an alternative location for users to obtain data and reduce the load on Stanford.

The GONG 2008/SOHO XXI meeting was held in Boulder, Colorado from August 11-15. Approximately 100 scientists were scheduled to gather to discuss solar-stellar dynamos as revealed by helio- and astero-seismology. See the Web page at [gongsoho08.ucar.edu/](http://gongsoho08.ucar.edu/) for further details.

The four students for this year's International Research Experience for Students (IRES) program arrived safely in Bangalore, India for a six-week program. Andrea Kunder (Dartmouth University), Erik Larson (University of Colorado), Driss Takir (University of North Dakota), and Catherine Wu (New Mexico State University) will be working

*continued*

*GONG++ continued*

with S. Giridhar, S.P. Bagare, U.S. Kamath, and S.K. Saha of the Indian Institute of Astrophysics (IIA). The students settled in quickly, and hosted a social event to meet the Indian graduate students at the IIA (see figure 2). Information about the summer school program, including project reports from last year's participants, can be found on the Web at [eo.nso.edu/ires/](http://eo.nso.edu/ires/).

We are happy to announce that Kiran Jain has officially joined the GONG staff. Kiran has been working with us as an NSO long-term visitor and serving as the IRES program coordinator. We are delighted that we can now provide financial support for her under NASA funding. ●



## International Research Experience for (Graduate) Students (IRES)

NSO/GONG announces a summer 2009 research program for US graduate students sponsored by the NSF Office of International Science and Engineering (OISE). The eight-week program, beginning June 10, 2009, will take place in Bangalore, India under the auspices of the Indian Institute of Astrophysics (IIA). The goal of the program is to expose potential researchers to an international setting at an early stage in their careers. See [eo.nso.edu/ires/](http://eo.nso.edu/ires/) for additional information and application materials.



## US IYA 2009 Momentum Grows with House Resolution, Prototype of Image Exhibition

*Douglas Isbell*

Planning for the International Year of Astronomy (IYA) 2009 (IYA2009) received a wonderful boost in recognition on 9 July 2008 when the US House of Representatives passed a resolution (H. Con. Res. 375) honoring the goals of the pending international year.

Introduced by Representative Gabrielle Giffords (D-8<sup>th</sup>, AZ), the resolution highlights the “profound implications” of astronomy for “science, philosophy, culture, and our general conception of our place in the Universe.” It also cites the “many creative programs and activities” planned for IYA 2009, which are “strongly supported by the staff, missions and observatories of the National Science Foundation and the National Aeronautics and Space Administration,” and it notes astronomy’s critical roles in education and economics.

The specific “resolved” bullets in the text state that Congress honors the goals of IYA2009 and encourages the public to participate in the celebrations. Giffords supported the bill on the House floor with an inspiring verbal statement, which followed eloquent speeches about the themes and goals of IYA 2009 by Representative Tom Feeney (R-24<sup>th</sup>, FL) and Representative Nick Lampson (D-22<sup>nd</sup>, TX).

We hope and expect the resolution will now move on to the US Senate, thanks to the continuing excellent background work on this issue



by American Astronomical Society (AAS) Policy Fellow Marcos Huerta.

Giffords’ district is located in the area in and around Tucson, Arizona, the home of numerous observatories and astronomers, along with the US point of contact for IYA 2009, the US program director for IYA 2009, and the leader of both the US and international dark-skies awareness theme for the year (all based at NOAO), so we anticipate more activity with her office and other local representatives.



To follow further progress, and see C-Span video of the House resolution floor speeches, check out the AAS Public Policy Blog by Marcos at [blog.aas.org](http://blog.aas.org).

Another US-led IYA 2009 cornerstone project, the image exhibition titled “From Earth to the Universe,” underwent a successful trial run in Liverpool, England, from June 7-29, outdoors at the Albert Dock. Read the full report by cornerstone co-leaders Kim Arcand and Megan Watzke of the Chandra Science Center at the Chandra blog, [chandra.harvard.edu/blog/node/77](http://chandra.harvard.edu/blog/node/77).

For more information on the exhibit and how to go about hosting it in your town, see [www.fromearthtotheuniverse.org](http://www.fromearthtotheuniverse.org).

## Another Successful Horse Camp on Kitt Peak; KOHN Show Debuts

More than 35 kids and a dozen adults attended the Sells Boys & Girls Club summer horse camp from June 20-22 at the picnic grounds on Kitt Peak.

The purpose of the horse camp is to help Tohono O’odham kids reconnect with their heritage, broaden their horizons, and reinforce the community values of the Tohono O’odham culture. Kitt Peak is an ideal environment for the camp, according to lead organizer Silas “Si” Johnson Jr., especially since it is so much cooler than the desert floor at this time of year.

Kitt Peak National Observatory (KPNO) supported the horse camp for the second year in a row by preparing the site, covering food costs, providing EMT support, and taking numerous photos that



*continued*

### *Horse Camp on Kitt Peak continued*

were shared with horse camp leaders. The first night of the camp included a star party with small telescopes provided by two NOAO staff members, two students from the KPNO Research Experiences for Undergraduates program, and dedicated volunteers from the Tucson Amateur Astronomy Association and NOAO's Project ASTRO program.

Some audio soundbites from several excited kids and adults at the camp were featured on the first edition of a new NOAO-produced, 30-minute monthly radio show on the main station in Sells, KOHN 91.9 FM, called "Clear Skies Over Kitt Peak." The first show also included an interview with KPNO Director Buell Jannuzi, and guidance from NOAO outreach scientist Katy Garmany on what to see in the night sky in July. 



Images: S. Kennedy and NOAO/AURA/NSF

## CADIAS Participates in Show of Integrated Arts in Argentina

*David Orellana*

The Centro de Apoyo a la Didáctica de la Astronomía (CADIAS) was invited to participate in a cultural show for the public in the city of Córdoba, Argentina, with the theme "Capital of Ocean and Stars."

The show consisted of artistic and cultural expressions, using a public space in the Paseo del Buen Pastor in the city center. This activity was organized and coordinated by the Council of Culture and Arts of Coquimbo, the Municipality of La Serena, and the Regional Government of Coquimbo, with the support of the Province of Córdoba and the Chilean Consulate in Argentina. The week-long event was inaugurated on June 19 with the participation of several important Chilean and Argentine authorities (figure 1), such as the Chilean Culture Minister, Córdoba's Secretary of Culture, and the Mayor of La Serena.

The show mounted by CADIAS was a success because of the well-coordinated sequence of activities and promotion done by the Chilean and Argentine authorities, and the great interest of teachers, school kids and general public in the astronomical activities proposed by the outreach team. The CADIAS presentation began with a description of the programs of CADIAS and the observatories of NOAO South, including SOAR and Gemini, as well as information on the University of La Serena and the Light Pollution Prevention Office (OPCC). The most popular elements of the show were the mobile planetarium sessions, and the use of a Meade LX200 telescope. The CADIAS booth included astronomy books from the



Córdoba Secretary of Cultura José García, La Serena Mayor Raúl Saldívar, Chilean Minister of Culture Paulina Urrutía, and David Orellana, director of CADIAS, at the opening day of the cultural show.

CADIAS library, and three exhibition panels with information about CTIO, CADIAS, and the International Year of Astronomy 2009, in which Chile will be an active participant.

*continued*

*CADIAS Participates in Show of Integrated Arts in Argentina continued*

During the week of the exhibition, the show was visited by more than 20,000 people, all of whom had the chance to receive information about the programs developed by NOAO and its partners around the globe, and to learn a little bit more about the Universe.

CADIAS is a community science center and Internet-connected library in Altovalso, Chile, located 14 kilometers east of La Serena. CADIAS is funded primarily by NOAO and Gemini, and receives additional support from the University of La Serena, the local city government, and the European Southern Observatory. 



Students in Córdoba prepare to enter the mobile planetarium.



CADIAS Director David Orellana speaks to some young attendees about the observatories of northern Chile  
Photos credit: D. Munizaga and NOAO/AURA/NSF

## A Research Adventure for Tucson Educators

*Eric Hooper (University of Wisconsin-Madison)*

Ever watch a science show on television—whether it’s about space flight, dolphins, or volcanoes— and think, “Wow, I’d like to do that!”

Now imagine non-astronomers thinking the same about our field. While the public may enjoy many illuminating astronomy talks and striking images on Web pages, opportunities to actively engage in research at any level are rare, and can be challenging to execute in a meaningful way. Hence, we all jumped at a good opportunity to involve Tucson educators in a WIYN research observing project.

Three Girl Scouts of the USA leaders and Tucson Unified School District (TUSD) teachers with strong bents for science education joined astronomers for two nights of observing on the WIYN 0.9-meter telescope. Carolyn Hollis (Girl Scouts, TUSD), Susan Hollis (Girl Scouts, TUSD), and Samantha Sims (TUSD) dove into all aspects of observing a set of quasars with the S2KB imager, working closely with me. Simultaneously, University of Wisconsin astronomer Marsha Wolf observed the same objects using Sparsepak and the Bench Spectrograph on the WIYN 3.5-meter telescope.

Everyone was kept busy helping to fill the Dewar, typing in coordinates, taking images, keeping a log, watching the weather, observing calibrators, collecting flats and biases, talking about the rationale for



Color composite of images of the Veil Nebula taken with the WIYN 0.9-meter telescope, using Yomama software. Credit: E. Hooper

*continued*

*A Research Adventure for Tucson Educators continued*

each step, and even starting to analyze the data. However, once the science targets were in the bag, we had a little time to exercise the instrument's 20-arcmin field of view on a few targets more visually compelling than point sources. These included nearby galaxies and nebulae—images which will find their way into classrooms and Girl Scout activities. Even minor glitches proved useful as group problem-solving exercises that can be turned into lessons.

Wolf and Kitt Peak Observing Associate Karen Butler greeted the educators at the WIYN 3.5-meter during their afternoon calibrations and explained the other part of the science project. "We're studying quasars and the galaxies in which they live using a spectrograph that can look at the various parts of the system simultaneously," explained Wolf. However, she pointed out that given the way she has to use the instrument, she can't calibrate the brightness of the variable quasar component. The educators and I had the job of making this calibration with the other telescope.

"To be immersed in this setting, and having time to talk about the educational issues and the kids and getting it across ... I am so charged up!" exclaimed Carolyn Hollis. We started discussing educational applications with the natural inclination of astronomers to explore data quantitatively, from altering display parameters, to measuring the sky background, and even some simple photometry of the target quasars. We used the Yale Observatory iMAge Manipulation Application (Yomama), a simple but powerful image display and analysis program written expressly for educational applications by David Goldberg (now at Drexel University).

The educators divided these activities by level for their varied students, from 3<sup>rd</sup> graders through high school. All three educators also converged on the use of our images to convey ideas about color, from the meaning of intensity values in images of different colors and how to make a true color image, to the need for false color images to represent non-visible radiation. As nascent lessons began to take shape, Susan Hollis pointed out that "we can work with these images on our own also using Gimp, clean them up, combine them."

Manipulating digital images of stunning natural objects provides a segue into art education. Samantha Sims explained that "some of the students come in with a real fear of artistic expression, but if you give them some parameters and a platform to ease them into their creative expression, sometimes it works a lot better." To complete the loop, beautiful celestial images created by students can catalyze an interest in astronomy. Many of these ideas may find expression not only in the classroom but also in a planned national Girl Scout astronomy-themed "Destinations" program for older girls.

Several elements contributed to the success of the venture. First, the project was relatively modest in scope and straightforward in execution, which afforded an opportunity to explore and discuss in a relaxed environment, while still retaining some research urgency.

It also benefited from active and enthusiastic participants, scientists interested and experienced in education and outreach, and the help and support of staff at WIYN and Kitt Peak National Observatory, as well as the NOAO Office of Public Affairs and Educational Outreach.

Finally, we would not have gotten off the ground without the financial and logistical support of University of Arizona astronomer Don McCarthy and his NIRCam/JWST education and outreach program for Girl Scouts, plus our University of Wisconsin-Madison collaborator and the overall principal investigator of the project, Andy Sheinis. 



Carolyn Hollis (left), in the driver's seat at the WIYN 0.9-meter, as Eric Hooper (right) looks on. Credit: S. Sims

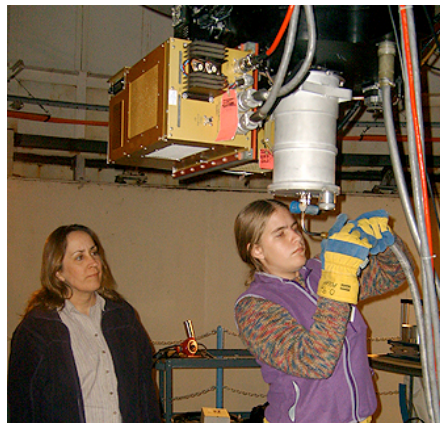

Marsha Wolf (left) and Susan Hollis (right) filling the Dewar with liquid nitrogen. Credit: S. Sims



Tucson teacher Samantha Sims filling in the log book. Credit: E. Hooper